



Università degli Studi di Milano-Bicocca
Scuola di Dottorato

DIPARTIMENTO DI FISICA G. OCCHIALINI
Corso di Dottorato in Fisica e Astrofisica XXXII ciclo
Curriculum in Fisica Teorica

Tesi di Dottorato

Duality walls and three-dimensional superconformal field theories

Dottorando:

Gabriele Lo Monaco

Matricola 814586

Tutore:

Prof. Alessandro Tomasiello

Coordinatore:

Marta Calvi

Contents

1	Introduction	5
I	$\mathcal{N} = 3$ and $\mathcal{N} = 4$ supersymmetric theories in three dimensions	11
2	Hanany-Witten construction	13
2.1	$\mathfrak{osp}(n 2, 2)$ super-algebra	13
2.2	Monopole operators	15
2.3	Moduli space of $\mathcal{N} = 3$ and $\mathcal{N} = 4$ theories	17
2.4	$T_\rho^\sigma[SU(N)]$ theories	22
2.5	Brane engineering	24
2.6	Supergravity realization	28
3	S-duality walls	30
3.1	Gaiotto-Witten construction	30
3.2	S-fold theories	35
3.3	Supergravity realization	37
II	Original part	40
4	The moduli spaces of S-fold CFTs	42
4.1	Models with one S-flip	42
4.1.1	Flavored affine A_1 quivers	43
4.1.2	Quivers with a $T[U(N)]$ loop	46
4.2	Warm-up: Abelian theories with CS levels	48
4.2.1	Example: $\mathbf{k} = (-1, +1, -1, +1)$	49
4.2.2	General Abelian linear quivers	53
4.2.3	Example: No cut in the quiver (4.52)	55
4.3	Theories with one J -fold	57
4.3.1	Cuts are needed	59
4.3.2	No cutting at all	63
4.4	Abelian models with fundamental matter	63
4.4.1	Warm-up: a model without J-folds	64
4.4.2	A model with one J-fold	66
4.5	A case with more J -folds	68
4.6	(p, q) -branes and J-fold theories	71

5	Variations on S-fold CFTs	76
5.1	Hanany-Witten systems with O-planes	77
5.1.1	O3-plane	78
5.1.2	O5-planes	79
5.2	S-fold models with an orientifold threeplane	82
5.2.1	Quiver with a $T[SO(2N)]$ loop	83
5.2.2	Quivers with a $T[SO(2N)]$ link or a $T[USp'(2N)]$ link	86
5.3	S-fold models with orientifold fiveplanes	89
5.3.1	Models with one or two antisymmetric hypermultiplets	90
5.3.2	S -folding the $USp(2N) \times U(2N) \times USp(2N)$ gauge theory	97
5.4	Models with the exceptional group G_2	99
5.4.1	Self-mirror models with a $T[G_2]$ link	99
5.4.2	More mirror pairs by adding flavors	103
6	Supersymmetric index of S-fold SCFTs	107
6.1	Superconformal multiplets and the index	108
6.2	A single $U(N)_k$ gauge group with a T -link and n flavors	110
6.2.1	The abelian case: $N = 1$	110
6.2.2	$U(2)_k$ gauge group and no flavor	111
6.2.3	Adding one flavor ($n = 1$) to the $U(2)_k$ gauge group	113
6.2.4	Adding n flavors to the $U(2)_2$ gauge group	116
6.3	Duality with theories with two gauge groups	117
6.4	$U(2)_{k_1} \times U(2)_{k_2}$ with two T -links	119
6.4.1	Adding flavors to the parabolic case	120
7	Conclusions and Perspectives	123
	Appendices	127
A	Hilbert series	127
A.1	The monopole formula	127
A.2	Coupling hypermultiplets to a nilpotent cone	128
B	Superconformal index	135

Chapter 1

Introduction

One of the most spectacular features of string theory is the presence of dualities relating apparently different theories. This characteristic is usually inherited by quantum field theories that are supposed to describe the low-energy behavior of some brane system. The first example where this inheritance has been pointed out is $\mathcal{N} = 4$ $SU(N)$ super Yang-Mills (SYM) theory in four dimensions, that is supposed to describe low energy field theory on a stack of N D3-branes on flat space. It turns out that Type-IIB brane setups actually come in $SL(2, \mathbb{Z})$ orbits of dual configurations. $SL(2, \mathbb{Z})$ duality leaves D3-branes invariant while transforms $\binom{p}{q}$ -branes into $M \binom{p}{q}$ branes, where M is a 2×2 matrix in the group.¹ As a consequence, Type-IIB supergravity also enjoys $SL(2, \mathbb{Z})$ duality; given a vacuum solution, we can generate a dual background with the same metric but different fluxes. For instance, the axio-dilaton² $\tau = C_0 + ie^{-\phi}$ transforms as follows:

$$\tau \rightarrow \frac{d\tau + c}{b\tau + a}, \quad \begin{pmatrix} a & b \\ c & d \end{pmatrix} \in SL(2, \mathbb{Z}). \quad (1.1)$$

Since the axio-dilaton is usually identified with the complexified coupling $\tau = \frac{\theta}{2\pi} + \frac{4\pi i}{g^2}$ on the field theory side, it is natural to think that $\mathcal{N} = 4$ SYM theories with different couplings can be actually dual [1]. One can imagine to apply the following transformation, usually called S-transformation:

$$S = \begin{pmatrix} 0 & -1 \\ 1 & 0 \end{pmatrix}, \quad \tau \rightarrow -\frac{1}{\tau} \quad (1.2)$$

and, assuming τ to be initially large, we can dualize the original strongly-coupled theory into a weakly-coupled one which we know how to deal with. From this example, it is clear how dualities can in general help in gaining insight about the strong-interacting regime of gauge theories.

Another notable example where the duality heritage of string theory manifests consists of three-dimensional $\mathcal{N} = 4$ field theories dual to Hanany-Witten (HW) configurations [2], made of D3, D5 and NS5 branes. In absence of orientifold planes, such configurations are dual to linear or circular quivers with $U(n_i)$ gauge nodes and (bi-)fundamental matter. A general linear quiver and

¹In our conventions, a $\binom{1}{0}$ -brane is an NS5-brane while a $\binom{0}{1}$ -brane is a D5.

²Here C_0 is the potential for the one-form RR flux while ϕ is the dilaton.

associated brane configuration is depicted in (1.3).

$$\begin{array}{c}
 n_1 \quad n_2 \quad \dots \quad n_r \\
 \circ \quad \circ \quad \dots \quad \circ \\
 | \quad | \quad \dots \quad | \\
 \blacksquare \quad \blacksquare \quad \dots \quad \blacksquare \\
 f_1 \quad f_2 \quad \dots \quad f_r
 \end{array}
 \quad
 \begin{array}{c}
 | \quad | \quad \dots \quad | \\
 \bullet \quad \bullet \quad \dots \quad \bullet \\
 | \quad | \quad \dots \quad | \\
 n_1 \quad n_2 \quad \dots \quad n_r
 \end{array}
 \quad (1.3)$$

where a vertical line represents an NS5 brane, an horizontal line represents a stack of n_i D3 branes and a dot stands for a set of f_i D5 branes. The branes span the following directions:

	0	1	2	3	4	5	6	7	8	9
D3	×	×	×				×			
D5	×	×	×					×	×	×
NS5	×	×	×	×	×	×				

(1.4)

HW configurations possess a supergravity dual that allowed for a number of remarkable holographic checks [3–6]. The background dual to a linear quiver is of the form $\text{AdS}_4 \times \text{S}^2 \times \text{S}^2 \times \Sigma$ where Σ is Riemann surface with the topology of the infinite strip. Whenever the strip can be cut and glued at two sides, we can get a new Riemann surface with the topology of the annulus: in such a case the background is dual to a circular quiver theory. Brane configurations associated to circular quivers can be constructed taking x^6 direction in (1.4) to be an S^1 .

Let us look at the action of the element $S \in \text{SL}(2, \mathbb{Z})$ on this models. S-duality, together with an appropriate rotations of coordinates, acts swapping D5 and NS5 branes [2, 7, 8] and manifests field-theoretically as mirror symmetry [9]; if two theories flows to the same IR fixed point and form a mirror pair, mirror symmetry swaps Coulomb and Higgs branch of such theories.³ Observe that mirror symmetry maps Higgs branch, which is classically exact and that we can access using UV knowledge only, to Coulomb, which receives quantum corrections instead. It is interesting to note that S-duality action can be also realized on the supergravity backgrounds, *i.e.* it swaps the two S^2 factors in the metric. S-duality can be generalized considering other elements of $\text{SL}(2, \mathbb{Z})$. A typical example is provided by the action of the following element:

$$T^k = \begin{pmatrix} 1 & 0 \\ k & 1 \end{pmatrix}. \quad (1.5)$$

It leaves D5-branes invariant while transforming NS5s into $\binom{1}{k}$ -branes [12, 13], responsible for turning on $\pm k$ Chern-Simons (CS) level in the dual quiver [14, 15]. This means that T^k duality transformations maps $\mathcal{N} = 4$ theories to ones with non-trivial CS terms, responsible for breaking supersymmetry down to $\mathcal{N} = 3$ at the Lagrangian level; however, the duality suggests that these theories actually have enhanced supersymmetry in the IR.⁴

As proposed [15, 17, 18], a duality transformation can be also performed locally in a given brane configuration. Let us focus on the case of $S \in \text{SL}(2, \mathbb{Z})$

³Even if mirror symmetry is much more simpler to recognize in $\mathcal{N} = 4$ theories, where the moduli space is made of two branches, Coulomb and Higgs, it is actually a duality for all three-dimensional theories with $\mathcal{N} \geq 2$ supersymmetry, as first observed in [10, 11].

⁴In the IR, supersymmetry can also get enhanced to $\mathcal{N} > 4$, like in the famous ABJM case [16].

action: this means that there exists a surface, called S-duality wall, passing through which the system undergoes an S-duality transformation. Following [15], where such interface is realized as a Janus domain wall in 4d $\mathcal{N} = 4$ SYM theory, the intersection between an S-duality wall and a stack of N D3-branes gives rise to a $T[U(N)]$ theory, that can be actually thought as a product theory, $T[U(1)] \times T[SU(N)]$. The first theory, $T[U(1)]$, is almost empty theory and consists of a mixed CS level between two $U(1)$ vector multiplets while the second one has the following Lagrangian realization:

$$\overset{1}{\circ} - \overset{2}{\circ} - \overset{3}{\circ} - \dots - \overset{N-1}{\circ} - \overset{N}{\blacksquare} \quad (1.6)$$

$T[U(N)]$ is a self-mirror theory and possesses $U(N) \times U(N)$ global symmetry.⁵ The $SU(N)$ group in the first factor is realized on the Higgs branch, *i.e.* it coincides with the flavor symmetry group manifest in (1.6); the second factor is emergent at low energies and it is not manifest in the UV. In a Hanany-Witten configuration where an S-duality wall has been inserted, the two $U(N)$ factors are gauged at the same time and the $T[U(N)]$ theory, also referred as T-link in the following, serves as coupling between two $U(N)$ vector multiplets. An example is depicted in figure (1.7), where we used a red line to denote a $T[U(N)]$ theory with gauged global symmetries.

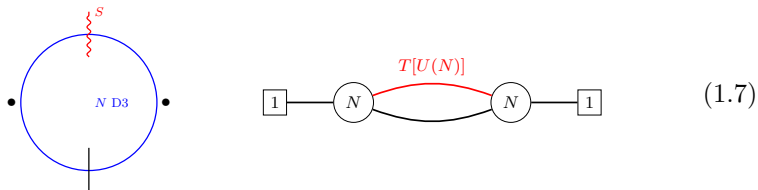

Using the same nomenclature proposed in [19], an S-duality wall is also called **S-fold**, or **S-flip** if we want to stress the absence of Chern-Simons terms. CS levels can be turned on considering walls for other elements in $SL(2, \mathbb{Z})$:

$$J_k = ST^k = \begin{pmatrix} k & 1 \\ -1 & 0 \end{pmatrix}. \quad (1.8)$$

Whenever a J_k duality wall, or **J-fold** for brevity, intersects a stack of N D3-branes, a $T[U(N)]$ theory appears: its global symmetries get gauged and a Chern-Simons level k is turned on for one of the two linked $U(N)$ gauge nodes. Circular Hanany-Witten configurations with one or more S-fold possess a supergravity dual, first proposed in [19, 20]. Such backgrounds have the form $AdS_4 \times S^2 \times S^2 \times \Sigma$ where this time Σ is an infinite stripe cut and glued at two points using an $SL(2, \mathbb{Z})$ element (S or J_k depending on the case). In other words, we perform a $SL(2, \mathbb{Z})$ quotient of the stripe, giving rise to a background with a non-trivial monodromy.⁶ It is interesting to observe that this kind of construction represents a notable example of non-geometric background.

⁵One can think the $U(1)$ factors in $U(N) \times U(N)$ to act trivially. Moreover, one can add background vector multiplets and mixed CS term for such multiplets. The backgrounds fields do not affect the 3d theory in any way. However, they become relevant in the gauging procedure, since they become dynamical and the mixed CS interaction gives rise to a $T[U(1)]$ theory.

⁶The idea of using $SL(2, \mathbb{Z})$ monodromy to obtain new solutions was also applied in other dimensions. For example, those in AdS5 was considered in [21, 22], and those in AdS3 were considered [23, 24].

The stringy origin and the existence of a supergravity dual make S-fold models a particularly interesting class to study. Investigating their properties turns out to be intriguing and challenging on the field theory side, due to the non-Lagrangian nature of the $T[U(N)]$ coupling. In fact, as we stressed above, the two $SU(N)$ global symmetries are not manifest at the same time in the description (1.6), but they co-exist only at low energies where an effective Lagrangian is not available. The aim of the works reviewed in this thesis is to gain insight about the main properties of this new class of SCFTs.⁷

In [29], we studied the moduli space of S-fold SCFTs dual to circular Hanany-Witten models with one S-fold inserted. We approach the problem in two different manners, depending on the nature of the duality wall. In the S-flip case, we considered configurations with an arbitrary number of D3-branes. We propose that the Higgs branch of an S-flip model can be computed performing a hyperkähler quotient: the $T[U(N)]$ link contributes to the quotiented space through a double copy of $\mathcal{N}_{SU(N)}$, the maximal nilpotent orbit of $SU(N)$. Such orbit is a hyperkähler manifold and coincides with both Higgs and Coulomb branch of $T[U(N)]$. Moreover, we propose that the Coulomb branch can be computed similarly to usual $\mathcal{N} = 4$ theories using the monopole formula proposed in [30], with the prescription that the vector multiplets from the gauge groups linked by $T[U(N)]$ do not contribute to the Coulomb branch dynamics. This means that the linked gauge groups are actually frozen and behave as fundamental matter. We refer to this prescription as **freezing rule** and we check our proposal against mirror symmetry, computing the Hilbert series in various classes of examples. J -fold models deserve a different treatment due to the presence of non-trivial Chern-Simons levels: in fact, in this case we are not able to provide a unique prescription in order to compute Coulomb and Higgs branches. For this reason we prefer to study a simpler class where only 1 D3-brane is present and thus all the gauge nodes are Abelian. $T[U(1)]$ is the unique theory that admits a Lagrangian description as mixed Chern-Simons term between the linked nodes. For this reason, we are able to perform explicit computations of moduli spaces of Abelian J -fold models. We show that the moduli space generically present a rich structure of branches, parametrized by mesons as well as dressed monopole operators. We present the various difficulties typical of this new class of theories studying selected and instructive examples. Finally, we show how S-fold theories can be used to study more general brane setups involving $\binom{p}{q}$ -webs.

$T[U(N)]$ theory admits an interesting generalization, denoted by $T[G]$, where G is a compact Lie group. A $T[G]$ theory possesses $G \times G^\vee$ global symmetry group, where G^\vee is the Langlands dual group of G . The factor G is realized on the Higgs branch while G^\vee factor is realized on the Coulomb branch and only emerges at low energies. The Higgs branch coincides with the maximal nilpotent orbit of G , \mathcal{N}_G , and similarly the Coulomb branch is identified with \mathcal{N}_{G^\vee} . We propose that whenever $G = G^\vee$, *i.e.* G is self-Langlands, the global symmetries of $T[G]$ can be commonly gauged, giving rise to a new T-link. In the case of $G = SO(2N)$ or $G = USp'(2N)$, we also propose that such coupling

⁷It is worth pointing out that the authors of [25–27] have studied (mainly in the context of the 3d-3d correspondence) very close cousins of the S-fold theories *à la* [19]. The difference between the two is that the gauge group is taken to be $SU(N)$ in the former, instead of $U(N)$ as in the latter. In absence of fundamental matter, the two cases turn out to be actually the same [28].

arises from the intersection of a duality wall and N D3 branes in a circular Hanany-Witten configuration where O3-planes or O5-planes have been inserted. The analysis in [15] suggests that these setups also have a stringy origin, even if a supergravity dual background is not available up to now. In [31] we studied the moduli space of S-flip models involving real classical groups. We computed the Hilbert series of various mirror pairs and check their consistency with mirror symmetry. We find that the freezing rule proposed in [29] still holds in this case and we also observe new phenomena such as the **screening effect**: an S-fold cannot be inserted “too close” to an O5-plane. The meaning of “too close” is specified in the main text. Together with real classical groups, we also studied an exceptional case consisting of circular quivers made of $USp(4)$, $SO(5)$ and G_2 gauge nodes. We propose for the first time, to the best of our knowledge, classes of mirror pairs involving G_2 gauge groups. Moreover, we observe that a $T[G_2]$ link can be inserted consistently with mirror symmetry.

Finally, we study the superconformal index of S-fold SCFTs. One purpose is studying in detail the amount of supersymmetry preserved by an S-fold theory. In fact, supersymmetry is naively broken down to $\mathcal{N} = 3$ because we gauge Coulomb and Higgs symmetries at the same time. However, an enhancement to $\mathcal{N} = 4$ or $\mathcal{N} = 5$ supersymmetry can occur at the IR fixed point for several models, including those with non-trivial Chern-Simons levels, which generically preserve $\mathcal{N} = 3$ supersymmetry. The enhancement of supersymmetry in large N limit has in fact been observed in [19], using holographic dual. At finite N , we study the possibility of supersymmetry enhancement computing the superconformal index in various examples, with and without flavor matter, stressing the agreement with the previous literature [28]. We also used the superconformal index to test dualities between S-fold theories having different quiver realization. In fact, as pointed out in [19], we can always make, for instance, a D5 brane pass a duality wall, trading it for NS5 branes. This move generates a chain of dual S-fold theories. We use the superconformal index to study how operators are mapped under the local duality transformation.

The presentation of the thesis is organized as follows. In the first part we collect some background material. In chapter 2 we review matter content and Lagrangian construction of $\mathcal{N} = 3$ and $\mathcal{N} = 4$ three-dimensional theories, with particular emphasis on the operators entering the low-energy dynamics and the moduli space. We put attention on the brane realization of such theories proposed by Hanany and Witten [2] and we present the main features of the Type-IIB backgrounds of [4,5]. In chapter 3, we review in detail the construction of Gaiotto and Witten of an S-duality wall. We present S-fold theories and the main features that can be inferred by the brane realization. We also comment on the dual Type-IIB vacua constructed in [19].

In the second part, we collect all the original contributions. In chapter 4 we present the main results of [29]. In particular, we study the moduli space of S-fold SCFTs dual to Hanany-Witten configurations made of N D3-branes wrapping S^1 and an S-fold. We propose an effective way to compute the moduli space of S-flip models and check it against mirror symmetry, performing explicit computations of Hilbert series in various examples. We also explicitly compute the moduli space of Abelian J -fold models and comment on the peculiarities of this class. In chapter 5 we studied the generalization of S-fold theories to models with more general $T[G]$ links. Using mirror symmetry as main tool, we deduce when an $T[G]$ link can be inserted in a consistent way, and we analyze in

detail models involving classical real groups. We propose such S-fold SCFTs to be dual to Hanany-Witten configuration where O-planes and S-folds co-exists. We also comment on the exceptional case $G = G_2$, for which we provide new classes of mirror pairs, with and without T-links. In chapter 6 we study the index of S-fold theories at finite N , focusing on supersymmetry enhancement, global symmetry enhancement and dualities; we comment and compare with previous literature.

Finally, in the appendix we collect some known facts about Hilbert series and superconformal index, together with some technical results used in the main text.

Part I

$\mathcal{N} = 3$ and $\mathcal{N} = 4$ supersymmetric theories in three dimensions

Chapter 2

Hanany-Witten construction

2.1 $\mathfrak{osp}(n|2, 2)$ super-algebra

$\mathcal{N} = 4$ field theories in 2+1 dimensions preserve half the maximal amount of supersymmetry, *i.e.* eight real supercharges; the fermionic generators of the supersymmetry transformations can be grouped in 4 (Majorana) spinors Q^I , $I = 1 \dots, 4$ such that:

$$\{Q_\alpha^I, Q_\beta^J\} = 2\sigma_{\alpha\beta}^\mu \delta^{IJ} P_\mu + 2\epsilon_{\alpha\beta} Z^{IJ} \quad (2.1)$$

where $\mu = 0, 1, 2$ are space-time indices, $\alpha, \beta = 1, 2$ are spinor indices and σ^μ denotes Pauli matrices; the momentum P_μ generates space-time translation while Z^{IJ} is the matrix of central elements. The algebra is invariant under $SO(4)$ rotations of the four supercharges Q^I , transforming in $\mathbf{4}$ representation: $SO(4)_R \sim SU(2)_C \times SU(2)_H$ is the R -symmetry group. This super-Poincaré algebra admits a conformal extension named $\mathfrak{osp}(4|2, 2)$, whose maximal bosonic sub-algebra is $\mathfrak{so}(2, 2) \times \mathfrak{su}(2)_H \times \mathfrak{su}(2)_C$.¹

Lagrangian field theories enjoying $\mathcal{N} = 4$ supersymmetry can be built using two building blocks: vector multiplet and hypermultiplet; their field content can be described in a more familiar fashion in terms of $\mathcal{N} = 2$ vector and chiral multiplets. A chiral multiplet Φ is complex and, introducing the Grassmann variable θ , can be written as:

$$\Phi = \phi + \sqrt{2}\theta\psi + \theta^2 F, \quad (2.2)$$

where ϕ is a complex scalar, ψ is a Dirac fermion and F is an auxiliary complex scalar as well; all such fields are assumed to depend on the composite coordinates $y^\mu = x^\mu + i\theta\sigma^\mu\bar{\theta}$. The vector multiplet is instead a real super-multiplet, containing a vector A_μ , a Dirac fermion λ and two (real) scalars, σ and D , with the latter being auxiliary; as usual, they can be collected in a unique super-field that, in the Wess-Zumino gauge, admits the following expansion:

$$V = -(\theta\sigma^\mu\bar{\theta})V_\mu - \theta\bar{\theta}\sigma + i\theta^2\bar{\theta}\bar{\lambda} - i\bar{\theta}^2\theta\lambda + \frac{1}{2}\theta^2\bar{\theta}^2 D, \quad (2.3)$$

¹In general, the super-conformal algebra $\mathfrak{osp}(\mathcal{N}|2, 2)$ has maximal bosonic sub-algebra $\mathfrak{so}(2, 2) \times \mathfrak{so}(\mathcal{N})$ and possesses $2\mathcal{N}$ fermionic generators.

where all the fields must be understood as depending on the usual space-time coordinates x^μ ; the kinetic term of the vector field is contained in the chiral field strength $W_\alpha = \frac{1}{4} \bar{D} \bar{D} e^{-V} D_\alpha e^V$, where we introduced the ‘‘covariant’’ derivatives:

$$D_\alpha = \partial_\alpha + i\sigma_{\alpha\beta}^\mu \bar{\theta}^\beta \partial_\mu, \quad \bar{D}_\alpha = \partial_\alpha + i\bar{\theta}^\beta \sigma_{\beta\alpha}^\mu \partial_\mu \quad (2.4)$$

anti-commuting with supersymmetry generators. Using these building blocks, the most general $\mathcal{N} = 2$ -preserving Lagrangian can be written as follows²:

$$S_{\mathcal{N}=2} = \int d^3x d^2\theta d^2\bar{\theta} \left(\frac{1}{g^2} W_\alpha W^\alpha - \Phi^\dagger e^{2V} \Phi \right) + \int d^3x d^2\theta \mathcal{W}(\Phi) + c.c., \quad (2.5)$$

where Φ is assumed to transform in some representation \mathcal{R} of the gauge group and \mathcal{W} is the superpotential.

$\mathcal{N} = 2$ fields can be now joined in order to define $\mathcal{N} = 4$ vector and hyper multiplet. In a schematic way, we can write:

$$\text{hyper } \mathcal{N} = 4 : Q + \tilde{Q}^\dagger \quad (2.6)$$

$$\text{vector } \mathcal{N} = 4 : V + \Phi \quad (2.7)$$

where Q and \tilde{Q} are chiral multiplets transforming in conjugate representations while the chiral field Φ is assumed to transform in the adjoint representation of the gauge group.³ More precisely:

$$\begin{aligned} \mathcal{N} = 4 \text{ hyper} : \quad & \begin{aligned} Q &= (q, \chi, F) \\ &\oplus \\ \tilde{Q}^\dagger &= (\tilde{q}^\dagger, \tilde{\chi}^\dagger, \tilde{F}^\dagger) \end{aligned} \quad \Rightarrow \quad \begin{aligned} (q, \tilde{q}^\dagger) &\in (\tfrac{1}{2}, 0) \\ &\oplus \\ (\chi, \tilde{\chi}) &\in (\tfrac{1}{2}, \tfrac{1}{2}) \\ &\oplus \\ (F, \tilde{F}^\dagger) &\in (0, \tfrac{1}{2}) \end{aligned} \end{aligned} \quad (2.8)$$

where we specified how multiplet components mix in order to form representations (s_1, s_2) of $SU(2)_C \times SU(2)_H$ R-symmetry group. Observe that, in order to define a honest $\mathcal{N} = 4$ multiplet, Q and \tilde{Q} must be taken in conjugate representations \mathcal{R} and $\bar{\mathcal{R}}$ under global and gauge symmetries. In the same way, we can summarize the vector-multiplet content as follows:

$$\begin{aligned} \mathcal{N} = 4 \text{ vector} : \quad & \begin{aligned} V &= (V_\mu, \lambda, \sigma, D) \\ &\oplus \\ &(\phi, \psi, F_V) \end{aligned} \quad \Rightarrow \quad \begin{aligned} (\sigma, \text{Re } \phi, \text{Im } \phi) &\in (1, 0) \\ &\oplus \\ (\lambda, \psi) &\in (\tfrac{1}{2}, \tfrac{1}{2}) \\ &\oplus \\ (D, \text{Re } F_V, \text{Im } F_V) &\in (0, 1) \end{aligned} \end{aligned} \quad (2.9)$$

The vector field V_μ is an R-symmetry singlet and Φ_V is taken in the adjoint representation of the gauge group. Given this decomposition, we can always write the most general Lagrangian preserving eight real supercharges in $\mathcal{N} = 2$

²For simplicity we focused on the case of one vector and one chiral multiplet: generalization to $\mathcal{N} = 2$ quiver gauge theories is straightforward.

³In the following, a chiral super-field Φ will be always understood as belonging to a $\mathcal{N} = 4$ vector multiplet; in the same way latin capital letters, as $(A, \bar{A}), (B, \bar{B}), (Q, \bar{Q})$ and so on, will be used to label chiral components of hypermultiplets.

language; the kinetic terms of a vector multiplet and a charged hyper can be written as

$$S_{\mathcal{N}=4 \text{ vector}} = \frac{1}{g^2} \int d^3x d^2\theta d^2\bar{\theta} \text{tr} \left(W_\alpha W^\alpha - \Phi_V^\dagger e^{2V} \Phi_V \right), \quad (2.10)$$

$$S_{\text{hyper, Kin}} = - \int d^3x d^2\theta d^2\bar{\theta} \left(Q^\dagger e^{2V} Q + \tilde{Q}^\dagger e^{2V} \tilde{Q} \right). \quad (2.11)$$

The most general form of the superpotential preserving $\mathcal{N} = 4$ supersymmetry is highly constrained. Let us consider a given hyper (Q, \tilde{Q}) transforming under a gauge group with gauge connection (V, Φ) ; then, the hyper enters a cubic superpotential by means of the following Lagrangian contribution:

$$S_{\text{superpotential}} = -i\sqrt{2} \int d^3x d^2\theta d^2\bar{\theta} \tilde{Q} \Phi Q + c.c.; \quad (2.12)$$

when more than one hyper is present, each of them enters the superpotential in the same way. As usual, the auxiliary fields F and D can be integrated out providing the actual scalar potential.

The $\mathcal{N} = 4$ multiplets and the Lagrangian terms we have met are also at the base of theories preserving $\mathcal{N} = 3$ supersymmetry. In that case, the algebra preserves six real supercharges only, rotated by an $SO(3)$ R-symmetry group, and admits a conformal extension $\mathfrak{osp}(3|2, 2)$. Supersymmetry can be broken explicitly by adding a simple contribution to an $\mathcal{N} = 4$ Lagrangian, (the supersymmetric version of) a Chern-Simons (CS) term:

$$S_{\text{CS}} = \frac{\kappa}{4\pi} \int d^3x d^2\theta d^2\bar{\theta} \int_0^1 dt \text{tr} \left[V \bar{D}^\alpha (e^{-tV} D_\alpha e^{tV}) \right] - \frac{\kappa}{4\pi} \int d^2\theta d^3x \text{tr} \Phi^2 + c.c. \quad (2.13)$$

Observe that the second contribution in (2.13) makes Φ enter the superpotential in a new way; the first contribution, instead, can be recognized to be an $\mathcal{N} = 2$ Chern-Simons term and needs the introduction of an auxiliary coordinate t in order to be written in a compact way exploiting superspace formalism; for this reason, it can be more illuminating writing down the $\mathcal{N} = 2$ CS term using the explicit field content:

$$S_{\text{CS}}^{\mathcal{N}=2} = \frac{\kappa}{4\pi} \int d^3x \text{tr} \left[A \wedge dA + \frac{2}{3} A \wedge A \wedge A - \bar{\lambda} \lambda + 2D\sigma \right] \quad (2.14)$$

2.2 Monopole operators

Other than vector and hyper multiplets, that can be defined in terms of usual local fields entering the UV Lagrangian, in three dimensions a new class of local operators can be introduced, monopole operators, playing a fundamental role in the following. Even if local, monopoles do not admit any polynomial expansion in terms of fundamental fields and various techniques are needed in order to study their behavior or taking into account their contribution to dynamics.

A monopole operator, $V_{\mathbf{m}}(x)$, is interpreted as a disorder operator generating a Dirac monopole singularity [32]; this means that gauge fields are required to behave as a Dirac monopole when approach the point of insertion x :

$$A_\pm \approx \frac{\mathbf{m}}{2} (\pm 1 - \cos \theta) d\varphi \quad (2.15)$$

where θ and ϕ parametrize a 2-sphere surrounding x .⁴ $\mathbf{m} \in \mathfrak{g}$ stands for an element of the gauge algebra and with an appropriate rotation, it can be always assumed to be in the Cartan sub-algebra of \mathfrak{g} ; thus, it can be expanded on a basis of Cartan generators,

$$\mathbf{m} = \sum_{i=1}^{\dim(G)} m_i H^i, \quad (2.16)$$

where m_i are named magnetic charges. Dirac quantization requires the respective group element, $e^{2\pi i \mathbf{m}}$, to act as the identity of the group on all the operators. Without loss of generality, we can take an operator whose quantum numbers specify a weight of a representation, $\boldsymbol{\mu}$, such that $H_i(\boldsymbol{\mu}) = \mu_i$. Dirac quantization implies [33]:

$$e^{2\pi i \mathbf{m} \cdot \boldsymbol{\mu}} \stackrel{D.Q.}{=} 1 \quad \Rightarrow \quad m_i \mu^i \in \mathbb{Z} \quad (2.17)$$

This condition can be recast in an elegant way as the requirement of $\{m_i\}$ to span the weight lattice of the Langlands dual group of G , usually denoted by G^\vee . The presence of a monopole operator breaks the gauge symmetry down to a subgroup; this is generated by all the elements of the algebra commuting with \mathbf{m} : they form an algebra $\mathfrak{h}_{\mathbf{m}}$ named commutant of \mathbf{m} in \mathfrak{g} . When turning to $\mathcal{N} = 2$ theories, a monopole also specifies a boundary condition for the real scalar sitting in a vector multiplet [32, 34]:

$$\sigma \approx \frac{\mathbf{m}}{r} \quad (2.18)$$

where r denotes the radial distance from the insertion point x ; in this sense, the monopole operator sits in an $\mathcal{N} = 2$ chiral multiplet. The same definition of monopole operator still holds in the $\mathcal{N} = 3$ and $\mathcal{N} = 4$ cases, *i.e.* the scalars belonging to the adjoint chiral multiplet Φ do not acquire any singular behavior.

Observe that any time the Langlands dual of the gauge group possesses a non-trivial center, $Z(G^\vee) \sim U(1)^j$ for some j , then a new global symmetry emerge, named topological symmetry; in fact, given the corresponding abelian gauge connections A_i , we can always build new conserved currents $J_T^i = \frac{1}{2\pi} \star dA_i$ whose conservation is guaranteed by Maxwell equations of motion. It turns out that monopoles are charged under topological symmetry. As an example, we can consider a $U(N)$ $\mathcal{N} = 2$ vector multiplet and magnetic charges (m_1, \dots, m_N) ; the topological symmetry $G_T = U(1)_T$ is associated to the $U(1)$ factor of the gauge group and the topological charge of the monopoles reads $J_T[V_{\mathbf{m}}] = \sum_i m_i$. Classically, monopoles are only charged under topological symmetry; however, at the quantum level, gauge and global charge of monopoles can become non-trivial thanks to quantum corrections due to all the fermions in the theory. Given N_f fermions $\{\psi_I\}$ transforming in representations \mathcal{R}_I of the gauge group with weights $\boldsymbol{\mu}_I^a$, the R-charge of a monopole reads [32, 35, 36]:

$$R[V_{\mathbf{m}}] = -\frac{1}{2} \sum_{I=1}^{N_f} \left(R[\psi_I] \sum_{a=1}^{\dim \mathcal{R}_I} |\boldsymbol{\mu}_I^a(\mathbf{m})| \right) \quad (2.19)$$

⁴As it is known, a Dirac monopole is actually specified by a couple of connections on the north and south hemisphere of the two-sphere. The two connections, A_\pm , are related by a gauge transformation.

where the index a runs over all the weights of a given representation. The monopole gauge charge with respect to a simple group with level κ has the following form:

$$J_{\text{gauge}}[V_{\mathbf{m}}] = -\kappa \mathbf{m} - \frac{1}{2} \sum_{I=1}^{N_f} \left(\Lambda_I \sum_{a=1}^{\dim \mathcal{R}_I} |\mu_I^a(\mathbf{m})| \right), \quad (2.20)$$

where $\Lambda_I = \sum_{a=1}^{\dim \mathcal{R}_I} \mu^a$ is the Weyl vector of the representation \mathcal{R}_I . A similar formula holds for global charges with $-\kappa \mathbf{m}$ and Λ_I substituted by background magnetic charges and global symmetry Weyl vectors respectively. Every time a monopole operator is not gauge invariant, it can be composed with an appropriate field in such a way to form a new gauge-invariant operator named dressed monopole.

Finally, let us notice that another definition of monopole operator is quite common in literature [10, 37], at least in the Abelian case. In fact, given an Abelian connection A_μ , it can be dualized in order to define a compact scalar \tilde{a} called dual photon:

$$\epsilon_{\mu\nu\rho} F^{\nu\rho} = \partial_\mu \tilde{a}. \quad (2.21)$$

If A_μ belongs to an $\mathcal{N} = 2$ vector multiplet, the dual photon can be combined with the adjoint scalar σ to form a new holomorphic operator:

$$V_m \sim e^{\frac{m}{g^2}(\sigma + i\tilde{a})}. \quad (2.22)$$

This can be understood as a definition of a monopole operator as a non-polynomial function of fundamental local fields.

2.3 Moduli space of $\mathcal{N} = 3$ and $\mathcal{N} = 4$ theories

The moduli space of a supersymmetric gauge theory is the space of all vacuum field configurations preserving all supercharges; moduli spaces of $\mathcal{N} = 3$ and $\mathcal{N} = 4$ gauge theories in three dimensions show particular interesting properties. In general, the space of vacua is defined as the set of solutions of F -terms minimizing the superpotential

$$\frac{\partial \mathcal{W}}{\partial Q_I} = \frac{\partial \mathcal{W}}{\partial \tilde{Q}_I} = \frac{\partial \mathcal{W}_I}{\partial \Phi_a} = 0, \quad (2.23)$$

together with solutions of D -terms. The superpotential is constrained to have the form (2.12)⁵ while $\{Q_I, \tilde{Q}_I\}$ and Φ_a collectively denote all chiral fields participating to hyper and vector multiplets. In order to understand which interesting properties arise, let us begin with a simple example. Consider an $\mathcal{N} = 4$ U(1) vector multiplet with N_f charge-1 hypermultiplets, *i.e.* $\mathcal{N} = 4$ QED with N_f flavors; in the following we will often write down quivers both in

⁵(2.13) must be also taken into account if non trivial CS levels are present.

$\mathcal{N} = 4$ and $\mathcal{N} = 2$ languages:

$$(2.24)$$

Using (2.12), the superpotential reads:

$$\mathcal{W}_{\text{QED}, N_f} = \sum_{I=1}^{N_f} \tilde{Q}^I \Phi Q_I. \quad (2.25)$$

Since Φ by definition transforms in the adjoint representation of the gauge group, it is actually a singlet under $U(1)$ gauge symmetry, while Q and \tilde{Q} have charge ± 1 respectively; the theory also possesses an $SU(N_f)$ flavor symmetry together with the topological $U(1)_T$ symmetry that charges monopoles only. We collected all the charges in table 2.3, where $[m_1, \dots, m_{N_f}]$ are Dynkin labels.

Fields	R	$U(1)_{\text{gauge}}$	$U(1)_T$	$SU(N_f)$
Φ	1	0	0	$[0, 0, \dots, 0]$
Q	1/2	+1	0	$[1, 0, \dots, 0]$
\tilde{Q}	1/2	-1	0	$[0, \dots, 0, 1]$

We can immediately read the F and D terms:

$$\Phi Q_I = \tilde{Q}^I \Phi = \sum_J \tilde{Q}^J Q_J = 0, \quad (2.26)$$

$$\sigma Q_I = \tilde{Q}^I \sigma = \sum_J (Q_J Q_J^\dagger - \tilde{Q}^J \tilde{Q}^{J\dagger}) = 0, \quad (2.27)$$

where σ is the scalar in the $\mathcal{N} = 2$ vector multiplet; with a little abuse of notation, we used the same symbol to indicate a chiral multiplet and the scalar contained in. (2.26)-(2.27) admit two solutions:

$[\sigma = \Phi = 0]$: In this case F and D terms are solved imposing Q_I and \tilde{Q}^I to be orthogonal ($\tilde{Q}^J Q_J = 0$) and to have equal norms ($Q_J Q_J^\dagger = \tilde{Q}^J \tilde{Q}^{J\dagger}$). These two conditions can be recasted in a more elegant way. Let us consider the meson operator $M_I^J = Q_I \tilde{Q}^J$. This matrix has by definition rank one, being the tensor product of two vectors, and it is constrained by F and D terms to have vanishing trace and square:

$$\text{tr } M = Q_I \tilde{Q}^I = 0, \quad M^2 = Q_I (\tilde{Q}^K Q_K) \tilde{Q}^I = 0. \quad (2.28)$$

Let us stress that this branch is parametrized by VEV of hypermultiplets only and it is usually called Higgs branch, \mathcal{H} , since the non-trivial expectation values of the hypermultiplets cause a completely Higgsing of the $U(1)$ gauge field. It can be described in a purely mathematical way as:

$$\mathcal{H} [\text{QED}_{\mathcal{N}=4}, N_f \text{ flav.}] = \{M \in \text{GL}(N_f, \mathbb{C}) \mid \text{tr } M = M^2 = 0\}. \quad (2.29)$$

It is widely believed that Higgs branch is not corrected at quantum level [38]. It is defined through expectation values of the mesons M_I^J , that become the effective degrees of freedom at low energy. The space in (2.29) is well known in literature: it is a hyperkähler manifold also describing the moduli space of one $SU(N_f)$ instanton on \mathbb{C}^2 .

$[Q = \tilde{Q} = 0]$: With this choice, all the constraints (2.26)-(2.27) are solved. One could think that this branch is thus parametrized by the expectation values of σ and Φ . However, it is important to stress that in this case it is necessary to take into account quantum effects [39,40]. First of all, σ combines with the dual photon to form monopole operators, that it turns out to be the correct degrees of freedom in the deep IR. Monopoles are labeled by the magnetic charge with respect to the $U(1)$ gauge group, V_m . Using (2.19)-(2.20), it is possible to determine the quantum numbers of a given monopole with magnetic charge m :

$$R[V_m] = \frac{N_f}{2} |m|, \quad J_{U(1)}[V_m] = 0, \quad J_T = m. \quad (2.30)$$

It is common lore that the whole magnetic lattice can be covered by combinations of monopoles with lowest R -charge, in our case $V_{\pm 1}$ or simply V_{\pm} . We can thus expect this branch to be generated by V_{\pm} and Φ ; however, as anticipated, quantum corrections induce constraints among them. Matching of the quantum numbers of such operators leads to the following guess:

$$V_+ V_- = \Phi^{N_f} \quad (2.31)$$

This branch of moduli space can be considered as parametrized by monopole expectation values only and is usually named Coulomb branch, since a $U(1)$ gauge group remains unHiggsed. As before, the space described in (2.31) is well known in literature and it is nothing but the orbifold $\mathbb{C}^2/\mathbb{Z}^{N_f}$. As for the Higgs branch case, this orbifold possesses an hyperkähler structure on it.

The fact that the moduli space of an $\mathcal{N} = 4$ theory always contains a Coulomb and Higgs branch⁶ and that both the cones are hyperkähler manifolds is not a coincidence but a completely general fact [7,9,40]. This can be seen in the following way: let us consider a completely generic $\mathcal{N} = 4$ theory with gauge group G and N_h hypermultiplets $\{Q_I^i, \tilde{Q}_j^I\}$ where i, j are gauge representation indices and $I = 1, \dots, N_h$; σ_a^b and ϕ_a^b will represent the real and complex scalar of the G vector multiplet. The F and D terms always have the following form:

$$(\Phi^a)^i_j Q_I^j = \tilde{Q}_j^I (\Phi^a)^j_i = \sum_K \tilde{Q}_j^K (T^a)^j_i Q_K^i = 0, \quad (2.32)$$

$$\sum_K \left(Q_K^\dagger T^a Q_K - \tilde{Q}^K T^a (\tilde{Q}^\dagger)^K \right) + g [\Phi, \bar{\Phi}]^a = 0, \quad (2.33)$$

$$(\sigma^a)^i_j Q_I^j = \tilde{Q}_j^I (\sigma^a)^j_i = [\text{Re } \Phi, \sigma] = [\text{Im } \Phi, \sigma] = 0. \quad (2.34)$$

⁶ In more complicated cases, also mixed branches can appear, where some mesons and monopoles are non-vanishing at the same time. However, it must be stressed that also in this case the two sets of operators participate to the dynamics independently and the mixed branch is actually a product of two manifolds. One factor of the product is parametrized by monopoles and the other by mesons. See for instance [41] for a detailed discussion.

On the Higgs branch, adjoint scalars VEVs are set to zero; for this reason, it is usually said that only $SU(2)_H$ factor of R-symmetry group acts non-trivially on Higgs branch. In order to impose the F and D terms, the following vector needs to vanish:

$$\boldsymbol{\mu}_H = \begin{pmatrix} \operatorname{Re} \left(\sum_K \tilde{Q}_j^K (T^a)^{j_i} Q_K^i \right) \\ \operatorname{Im} \left(\sum_K \tilde{Q}_j^K (T^a)^{j_i} Q_K^i \right) \\ \sum_K \left(Q_{K,j}^\dagger Q_K^i - \tilde{Q}_j^K (\tilde{Q}^\dagger)_i^K \right) (T^a)^{j_i} \end{pmatrix} = 0. \quad (2.35)$$

This can be seen as the mathematical definition of hyperkähler quotient with the components of vector $\boldsymbol{\mu}_H$ being the moment maps; thus, by definition, the Higgs branch of an $\mathcal{N} = 4$ theory must be an hyperkähler manifold, with $SU(2)_H$ being identified with the automorphism rotating the three hyperkähler complex structures. Observe that when the number of hypermultiplets is big enough, their non-trivial VEVs trigger a complete Higgsing of the gauge group; in the following, we always assume this to be the case. On the other hand, on the Coulomb branch all the hypermultiplets have zero expectation value, $Q = \tilde{Q} = 0$ and the Coulomb branch is parametrized by adjoint scalars, $\{\operatorname{Re} \Phi, \operatorname{Im} \Phi, \sigma\}$ being rotated by $SU(2)_C$ factor of R-symmetry group. Because of (2.34), scalars must commute and they cause a Higgsing of the gauge group down to its maximal torus $U(1)^{\operatorname{rank}(G)}$: on the Coulomb branch we still have an Abelian theory, as the name suggests. Due to quantum effects, it is much trickier to recognize that Coulomb branches always possess an hyperkähler structure but we can provide some hints about the correctness of this statement. First of all, we can think the triplet of adjoint scalars as associated to three complex structures of a manifold, rotated by an $SU(2)$ automorphism: this would be exactly the quaternionic structure underlying an hyperkähler manifold. Moreover, they can combine together with the dual photon to form the four real scalar components of $\operatorname{rank}(G)$ hypermultiplets that can be thought of as living on the Coulomb branch strictly. Their VEVs can be taken as the coordinates on an hyperkähler manifold.

A much stronger argument comes from Mirror symmetry. Mirror symmetry consists of a duality between ($\mathcal{N} = 4$) theories in three dimensions flowing to the same IR fixed point⁷; it states that for any theory T_A with Higgs and Coulomb branches $\{\mathcal{H}_A, \mathcal{C}_A\}$, there always exist a companion field theory T_B with the two moduli space cones swapped, $\mathcal{H}_B = \mathcal{C}_A$ and $\mathcal{C}_B = \mathcal{H}_A$. Since any Higgs branch is hyperkähler, then any Coulomb branch must have a hyperkähler structure on it too. We will not enter in the mathematical details about hyperkähler manifolds: in the following, it is enough for us to know that their real dimension is always a multiple of 4, due to their quaternionic structure. Even if determining the Higgs or Coulomb cone of a given Lagrangian $\mathcal{N} = 4$ gauge theory can be sometimes a difficult task, determining their quaternionic dimension often reduces to a simple counting problem. Let us consider Higgs branch first: as we have seen, this is parametrized by the VEVs of scalars in hypermultiplets; each of them contains in particular 4 real scalars, $(\operatorname{Re} Q_I, \operatorname{Im} Q_I, \operatorname{Re} \tilde{Q}_I, \operatorname{Im} \tilde{Q}_I)$ that can be thought of as coordinates of an hyperkähler manifold and we can guess that

⁷Mirror symmetry has been proposed first in [9] for $\mathcal{N} = 4$ theories, due to the particular form of the moduli space. In [10, 11], mirror symmetry has been shown to be a duality also for $\mathcal{N} = 2$ theories.

the quaternionic dimension of such space equals the number of hypermultiplets. Nevertheless, we must recall that once hypers get a VEV, the gauge group is Higgsed, and the vectors “eat” a number of scalars equal to the dimension of the group. Thus we can state that:

$$\dim_{\mathbb{H}} \mathcal{H} = \#\text{hyper} - \dim(G). \quad (2.36)$$

Now we can consider the Coulomb branch; it is parametrized by expectation values of scalars sitting in vector multiplets together with the dual photons. Again, such VEVs cause a Higgsing of the gauge group down to the maximal torus $U(1)^{\text{rank}(G)}$ and the original theory reduces at low energy to an $\mathcal{N} = 4$ Abelian theory. We can claim that:

$$\dim \mathcal{C} = \text{rank}(G). \quad (2.37)$$

When Chern-Simons couplings are present, the story is slightly different. In order to understand the main differences when supersymmetry is broken down to $\mathcal{N} = 3$, let us begin again with an instructive example, QED with N_f flavors and level κ ; equations (2.26),(2.27) get modified in the following way:

$$\Phi Q_I = \tilde{Q}^I \Phi = 0, \quad \sum_J \tilde{Q}^J Q_J = \kappa \Phi, \quad (2.38)$$

$$\sigma Q_I = \tilde{Q}^I \sigma = 0, \quad \sum_J (Q_J Q_J^\dagger - \tilde{Q}^J \tilde{Q}^{J\dagger}) = \kappa \sigma, \quad (2.39)$$

In this case the branch where hypermultiplets vanish, $Q = \tilde{Q} = 0$ is completely lifted, since now F and D terms would imply $\Phi = \sigma = 0$. On the other hand, when $\phi = \sigma = 0$, we again recognize the moduli space of one $SU(N_f)$ instanton on \mathbb{C}^2 . Generalizing the previous discussion, we observe that the presence of a Chern-Simons level can lift the Coulomb branch while the Higgs branch is untouched. Due to the corrections to F and D terms because of the CS level, mesons and monopoles can acquire expectation value at the same time.⁸ For this reason, on these branches there can be a complicated dynamics where mesons and monopoles participate at the same time and do not decouple (in contrast to mixed branches of $\mathcal{N} = 4$ theories, see footnote 6). These branches may be not unique: we call the one with maximal dimension Coulomb branch and the other ones mixed branches. Also for $\mathcal{N} = 3$ theories, Higgs, Coulomb and mixed branches are hyperkähler manifolds, because scalars and equations of motions always organize into triplets rotated by an $SU(2)$ R-symmetry; such R-symmetry can be thought of as the $\mathcal{N} = 4$ R-symmetry $SU(2)_C \times SU(2)_H$ broken down to the diagonal subgroup. Mirror symmetry is still a duality and $\mathcal{N} = 3$ theories always come in pairs.

As a final comment, let us observe that information about a hyperkähler space can be encoded in a generating function called Hilbert series; it consists of a formal series of the following type⁹:

$$H[t, (w)] = \sum_{n=0} \chi_n[\mathbf{w}] t^n \quad (2.40)$$

⁸This is evident, for instance, in 2.38 where the trace of the meson operator is set equal to the VEV of an adjoint scalar.

⁹See for instance [42, 43] as interesting reviews.

where t is a fugacity relative to R-symmetry and $\chi_n(\mathbf{w})$ are characters of global symmetries depending on fugacities \mathbf{w} . This means that the coefficient of t^n contains information about the number of chiral operators having R-charge n together with their representation under non-R global symmetries. As an example, the moduli space of one $SU(N_f)$ instanton on \mathbb{C}^2 has the following Hilbert series [44]:

$$H_{(2.29)}[t, \mathbf{w}] = \sum_{n=0} \chi_{[n,0,\dots,n]}^{SU(N_f)} t^n. \quad (2.41)$$

We immediately recognize that we have an operator with R-charge one and transforming in the representation with Dynkin label $[1, 0, \dots, 1]$, *i.e.* the adjoint representation: this is nothing but the meson! With similar considerations, it is possible to extract information about the moduli space of $\mathcal{N} = 3$ and $\mathcal{N} = 4$ gauge theories in a simpler way. We will present various available techniques that allows to compute Hilbert series in the following.

2.4 $T_\rho^\sigma[SU(N)]$ theories

Among the all possible $\mathcal{N} = 4$ theories that can be built, the so-called T_ρ^σ theories represent a very notable example. A lot of their features have been studied in the past years, such as their partition function [6, 45, 46], Hilbert series [47–50] or superconformal index [51]. Part of the interest in such theories is due to the fact that they possess an holographic dual in Type-IIB supergravity providing several checks. All the $T_\rho^\sigma[SU(N)]$ models consist of linear quivers:

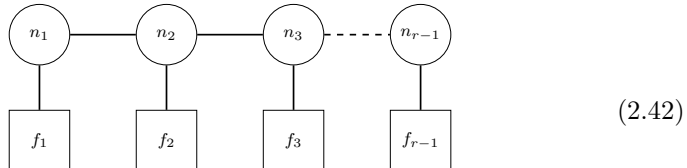

Each quiver is formed by $r - 1$ gauge nodes, each with gauge group $U(n_i)$ and f_i fundamental hypermultiplets rotated by $U(f_i)$ flavor symmetry group. Lines connecting two gauge nodes represent hypermultiplets in the bifundamental representation of the linked nodes. It must be stressed that not all possible sets $\{n_i\}$, $\{f_i\}$ are admitted: some choices corresponds to theories where some monopoles go under the unitarity bound, signaling a so-called bad theory in the sense of [15]. The two sets of positive integers specifying a $T_\rho^\sigma[SU(N)]$ theory can be exchanged in favor of two Young tableaux. ρ is tableau specified by the length of its r rows, $\rho_1 \geq \dots \geq \rho_r$ and such that $\sum_{i=1}^r \rho_i = N$ for some fixed N . In the same way, σ is made of p rows of increasing length σ_i and such that $\sum_{i=1}^p \sigma_i = N$. However, it is also convenient introducing the transpose tableau σ^T , made of p^T rows of length σ_i^T . The flavor symmetry groups are simply determined by σ^T :

$$f_i = \sigma_i^T - \sigma_{i+1}^T, \quad \sigma_i^T = 0 \text{ if } i > p^T, \quad (2.43)$$

while the ranks of the gauge groups are determined by the following relation:

$$n_i = \sum_{j=i+1}^r \rho_j - \sum_{j=i+1}^{p^T} \sigma_j^T. \quad (2.44)$$

The condition on unitarity of the theory is thus replaced by the condition, $\sigma^T \leq \rho$, using the so called dominance ordering of Young tableaux. Observe that symmetries on the Higgs branch can be always read directly from the quiver, $S(\prod_{i=1}^r U(f_i))$. Global symmetry group on the Coulomb branch, instead, is more subtle: at the classical level it consists of topological symmetries $U(1)^r$ only; however, it can enhance to a non-abelian group in the IR. Let us assume that a subset of r' of adjacent nodes is balanced, meaning that each of them satisfies the relation $n_{i+1} + n_{i-1} + f_i = 2n_i$. This subset of nodes can be put in correspondence with a Dynkin diagram, suggesting that the topological group $U(1)^{r'}$ actually enhances to $SU(r' + 1)$. In fact, as pointed out in [15], when a node is not balanced, there exists in the infrared a monopole operator with conformal dimension 1 and it is the lowest component of a superconformal multiplet containing a conserved current. When r' consecutive gauge nodes are balanced, such conserved currents generates the maximal torus $U(1)^{r'}$ of $SU(r' + 1)$ and the global symmetry enhances. Beside the global symmetries on the Higgs and Coulomb cones, a completely geometrical description of the moduli space of such theories is available. Using the Jacobson-Morozov theorem [52], to each tableau $\rho = [\rho_1, \rho_2, \dots]$ with N blocks, it is possible to assign a nilpotent element of $SU(N)$, that we will denote as $\rho^{(+)}$. Each $\rho^{(+)}$ can be always put in a standard form:

$$\rho^{(+)} = \left(\begin{array}{ccc} J_{\rho_1^T} & & \\ & J_{\rho_2^T} & \\ & & \ddots \end{array} \right), \quad J_{\rho_i^T} = \left(\begin{array}{ccc} 0 & 1 & \\ & 0 & 1 & \\ & & \ddots & \ddots \end{array} \right) \rho_i^T. \quad (2.45)$$

Observe that each $J_{\rho_i^T}$ can be seen as a raising operator of $\mathfrak{su}(2)$ in the ρ_i^T -dimensional representation; for this reason, it is often said that $\rho^{(+)}$ defines an embedding of $\mathfrak{su}(2)$ into $\mathfrak{su}(N)$ with rising operator $\rho^{(+)}$, lowering operator $\rho^{(-)} = (\rho^{(+)})^\dagger$ and Cartan generator $\rho^{(3)} = [\rho^{(+)}, \rho^{(-)}]$. From each raising operator, we can build an orbit in $SU(N)$:

$$\overline{\mathcal{O}}_\rho = \{g^{-1} \rho^{(+)} g \mid \forall g \in SU(N)\}. \quad (2.46)$$

$\overline{\mathcal{O}}_\rho$ is said nilpotent orbit of ρ and it is a manifold with a hyperkähler structure on it; an orbit $\overline{\mathcal{O}}_\sigma$ is contained in $\overline{\mathcal{O}}_\rho$ if $\sigma < \rho$ in the sense of dominance ordering. The nilpotent orbit $\overline{\mathcal{O}}_{[1^N]}$ is the biggest orbit of $SU(N)$ and it is often referred to as maximal nilpotent orbit of $SU(N)$, $\mathcal{N}_{SU(N)}$. Given a T_ρ^σ theory, its Coulomb and Higgs branches can be identified with the following hyperkähler spaces:

$$\mathcal{H}[T_\rho^\sigma] = \overline{\mathcal{O}}_\rho \cap \mathcal{S}_{\sigma^T}, \quad \mathcal{C}[T_\rho^\sigma] = \overline{\mathcal{O}}_\sigma \cap \mathcal{S}_{\rho^T}, \quad (2.47)$$

where \mathcal{S}_ρ is the so-called Slodowy slice transverse to $\overline{\mathcal{O}}_\rho$. It can be defined as follows: let us consider the embedding defined by $\rho^{(+)}$: the elements of $\mathfrak{su}(N)$ decompose in representations of this $\mathfrak{su}(2)$ sub-algebra. One may pick in particular elements \mathbf{t}^a such that:

$$[\rho^{(3)}, \mathbf{t}^a] = m_a \mathbf{t}^a. \quad (2.48)$$

Using this elements, we can construct the Slodowy slice as the following subset in $\mathfrak{su}(N)$:

$$\mathcal{S}_\rho = \{\rho^{(+)} + \sum_a y_a \mathbf{t}^a\} \quad (2.49)$$

with y_a arbitrary coefficients. Finally, action of mirror symmetry simply map T_ρ^σ in T_ρ^ρ .

The most important model for the following discussion corresponds to the case $\rho = \sigma = [1^N]$; it is usually denoted simply by $T[SU(N)]$ and the corresponding quiver is:

$$(2.50)$$

Higgs and Coulomb branches are both the maximal nilpotent orbits $\mathcal{N}_{SU(N)}$ with $SU(N)$ flavor groups acting on them; in fact, all the $N - 1$ gauge nodes of the quiver (2.50) are balanced so that the $U(1)^{N-1}$ topological symmetry completely enhances in the IR. Because of this enhancement, it is not possible to find a Lagrangian description at the fixed point with manifest $SU(N)^2$ symmetry. One can also imagine the theory in (2.50) to possess extra $U(1)^2$ global symmetry acting trivially. Moreover, one may decide to turn on background gauge fields a_i^{Bk} for such Abelian factors, adding to the Lagrangian a mixed Chern-Simons term for them:

$$\delta\mathcal{L}_{T[SU(N)]} = -\frac{1}{4\pi} \int a_1^{\text{backg.}} \wedge da_2^{\text{backg.}} + \text{susy completion.} \quad (2.51)$$

This interaction does not affect the dynamics at this stage. However, it is relevant in a gauging procedure, since this induce a mixed CS interaction between two gauge vector multiplets. This slightly deformed theory is called $T[U(N)]$ and is said to possess $U(N)^2$ global symmetry (at the infrared fixed point) in the sense discussed. (2.51) is sometimes thought of as an almost empty theory by its own and called $T[U(1)]$. Observe that $T[U(N)]$ is a self-mirror theory.

Up to now, we discussed gauge theories with U groups only. However, it is possible to build classes of $\mathcal{N} = 4$ linear quivers, analogue to T_ρ^σ , but with different symmetry groups realized on Higgs and Coulomb branches; again, these theories can be put in one-to-one correspondence with pairs of nilpotent orbits of a given Lie group.¹⁰ In the following, we will be interested in models, usually denoted by $T[G]$, whose moduli space is realized as a product of maximal nilpotent orbits $\mathcal{N}_G \times \mathcal{N}_G$ with flavor symmetry $G \times G$. It turns out that this is possible if and only if the group G is self-Langlands dual and in particular in the rest of the thesis we focus on $SO(2N), USp'(2N)$ and G_2 cases.¹¹ We will provide the explicit quiver construction of such models in the appropriate sections.

2.5 Brane engineering

$\mathcal{N} = 4$ linear quivers admit a general brane engineering first proposed by Hanany and Witten [2] and named after them. Hanany-Witten (HW) setup consists of

¹⁰The relation between nilpotent orbits of classical and exceptional groups and Moduli spaces of $\mathcal{N} = 4$ theories is an argument extensively studied in literature. A more exhaustive analysis can be found in [53–55].

¹¹ $USp'(2N)$ group is subtle. Its definition is intrinsically related to its use in quantum field theory as gauge group; in particular it differs from $USp(2N)$ for the matter representations and magnetic charges admitted. In four dimensions this is also related to the presence of a non-trivial theta angle $\theta = \pi$ [56].

NS5, D5 and D3 branes spanning the following directions:

	0	1	2	3	4	5	6	7	8	9
D3	×	×	×				×			
D5	×	×	×					×	×	×
NS5	×	×	×	×	×	×				

(2.52)

Observe that in this configuration the ten-dimensional Lorentz group $SO(1, 9)$ is broken down to $SO(1, 2) \times SO(3)_{345} \times SO(3)_{789}$; the first factor, $SO(1, 2)$, can be identified with the Lorentz group of the effective three-dimensional theory living on the stack of D3-branes. The two $SO(3)$ groups acting on $\{3, 4, 5\}$ and $\{7, 8, 9\}$ directions can be identified with R-symmetry instead; in particular, $SO(3)_{789}$ can be identified with the $SU(2)_H$, while $SO(3)_{345}$ is related to $SU(2)_C$. The most general brane system has the following form:

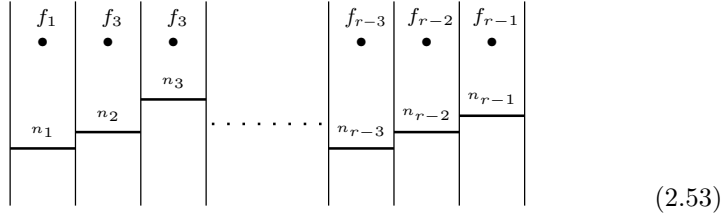

Each vertical line represents an NS5-brane. The i -th and $(i+1)$ -th NS5-brane are connected by n_i D3-branes ending on them; in the i -th interval, f_i D5-branes can be added and they are signaled by black dots. Given a brane configuration, the effective $\mathcal{N} = 4$ gauge theory living on the D3-branes is quite simple to determine. To each stack of n_i D3s in the i -th interval we associate a $U(n_i)$ gauge group and two consecutive nodes are “connected” by an hypermultiplet transforming in the bi-fundamental representation $(\mathbf{n}_i, \overline{\mathbf{n}}_{i+1})$. If the i -interval also contains f_i D5-branes, we add to the quiver f_i hypermultiplets transforming in the fundamental representation of the i -th gauge node. Using these rules, one immediately recognize that the brane configuration (2.53) is associated to the linear quiver (2.42). Observe that NS5-branes are in general related to vector multiplets while D5 ones bring information about hypermultiplets.

The positions of branes in a given setup also have a suggestive interpretation. In order to make the discussion lighter, let us consider the following brane configuration:

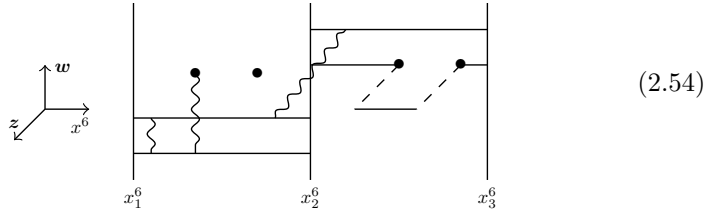

In the previous picture we collect the coordinates $\{x^3, x^4, x^5\}$ in the vector \mathbf{w} and the coordinates $\{x^7, x^8, x^9\}$ in the vector \mathbf{z} . Moreover, we represented fundamental strings with wiggly lines. Let us also stress that in (2.54), the dots should be understood as branes extending in the \mathbf{z} direction. Following our previous discussion, on each stack of coincident D3-branes lives a $U(2)$ gauge

theory, whose coupling constant is identified with the distance along x^6 of two consecutive NS5-branes.

$$\frac{1}{g_i^2} = |x_i^6 - x_{i+1}^6|. \quad (2.55)$$

In this sense, the limit of coincident NS5-branes is translated as a strong coupling limit on the quantum field theory side. Vector field degrees of freedom are usually identified with fluctuations of fundamental strings connecting D3s in the same stack. When the two D3-branes get separated in some direction, the fundamental strings acquire a non-trivial tension, interpreted as the mass of a W-boson; in figure (2.54), the D3-branes in the first segment are separated in the \mathbf{w} direction and the gauge group has been Higgsed down to the maximal torus $U(1)^2$. This is exactly what usually happens on the Coulomb branch! We can thus expect that the positions \mathbf{w}_{D3}^a to parametrize the VEV of the scalars in vector multiplets; any time D3s are free to move in the \mathbf{w} directions, this signals a non-trivial Coulomb branch. Let us consider now strings in (2.54) connecting D3-branes in adjacent stacks: Chan-Paton decoration suggests that their fluctuations are nothing but bi-fundamental hypermultiplet degrees of freedom. Any time two adjacent D3-branes are displaced in the \mathbf{w} direction, $\mathbf{w}_i^a - \mathbf{w}_{i+1}^b \neq 0$, fundamental strings possess non-vanishing tension and the hypers become massive; when D3-branes align, bi-fundamental hypermultiplets become massless. In the very same way, strings stretching between a D5-brane and a D3-branes carry the degrees of freedom of flavor hypermultiplets transforming in the fundamental of the gauge group; moreover the distance in the \mathbf{w} direction can be again interpreted again as a mass. When some D5-branes align with a stack of D3-branes, some flavor multiplet becomes massless. At the same time, portion of D3-branes now links D5-branes and are free to displace in the \mathbf{z} direction and the displacement can be thought as a mass for W-bosons. Since we can always add an arbitrary number of D5-branes, we can in principle reach a configuration in which the gauge group gets completely Higgsed, similarly to what happens on the Higgs branch. Any time a D3-brane is free to move in \mathbf{z} direction, this signals a non-trivial Higgs branch.

In terms of brane configuration, mirror symmetry exchanging Higgs and Coulomb branch has a simple interpretation: its action is the same of S -duality, exchanging D5 and NS5 branes. Building the S -dual brane configuration can be sometimes tricky; in fact, we must respect some physical requirement:

- Before taking the S -dual, all the D5-branes must be aligned to the D3-branes and separated along the x^6 direction.
- The net number of D3-branes ending on a 5-brane¹² must be conserved.
- Only one D3-brane can have a given D5-NS5 pair as endpoints; in fact it turn out that this is the unique configuration preserving supersymmetry and this rule is often referred to as “ S -rule”. Such D3-brane connecting branes of different kind is considered stacked and not free to move, since it ends on branes spanning different directions.
- Segments of D3-branes stretching between two NS5(D5)-branes are considered free to move in $\{3, 4, 5\}(\{7, 8, 9\})$ directions.

¹²*i.e.* the number of D3s ending from the left minus the number of D3s ending from the right in the NS5 case, vice-versa for a D5.

Let us apply this rules to an explicit example; let us consider a $U(2)$ gauge theory with four flavors and its companion brane configuration:

$$(2.56)$$

In order to get the mirror theory, we can take brane configuration, align the D5 and D3 branes and apply an S -transformation without violating S -rule and preserving the net number of D3s ending on a 5-brane:

$$(2.57)$$

The S -dual brane configuration can be refined using a so-called Hanany-Witten move. Given a D5 and an NS5 brane connected by a D3-brane, this configuration can be traded for a new one, where the D3 brane disappeared and the D5-brane crossed the NS5 one:

$$(2.58)$$

As observed in [2], Hanany-Witten move is nothing but the manifestation of the conservation law for RR and NS three-form fluxes. Applying HW moves to the external D5-branes in (2.57), we finally obtain the theory dual to $U(2)$ with four flavors:

$$(2.59)$$

The same procedure can be used in more general settings in order to obtain couples of mirror configurations and theories. Using HW moves, it is possible to construct T_{ρ}^{σ} theories in a simpler fashion. Let us consider two diagrams $\rho = (\rho_1, \dots, \rho_r)$ and $\sigma = (\sigma_1 \dots \sigma_s)$, both with total number of blocks N . We can draw a brane system consisting of s consecutive D5-branes and then r consecutive NS5s. σ_1 represents the number of D3 brane ending on the more internal D5-brane and so on; in the same way, ρ_1 is the net number of D3-branes ending on the more internal NS5-brane and so on. S -rule uniquely fixes such an initial configuration and using HW moves we can trade it for a usual setup where all the D3s stretch between NS5s:

$$(2.60)$$

2.6 Supergravity realization

All the $\mathcal{N} = 4$ three-dimensional linear quivers admit a Type-IIB holographic background $\text{AdS}_4 \times M_6$, first discovered in [3]; the holographic duality proposed has been subsequently studied and checked in [4, 5] and it is one of the most notable examples of AdS/CFT duality. Some features of the internal space M_6 can be guessed thinking at the supposed dual conformal theory: for instance, R-symmetry is realized, on the supergravity side, as isometry group of the internal space with non-trivial action on the supercharges. In the case of our interest, R-symmetry group is a double copy of $SU(2)$, whose unique orbits are S^2 or S^3 . An educated guess for the holographic background is then $\text{AdS}_4 \times S^2 \times S^2 \times \Sigma^2$ where Σ^2 is a to-be-determined Riemann surface. The background is thus specified by the choice of warpings, dilaton and fluxes. Since all these quantities must be invariant under isometries, the most general ansatz is:

$$ds^2 = e^{2A} ds_{\text{AdS}_4}^2 + e^{2\Delta_1} ds_{S_1^2}^2 + e^{2\Delta_2} ds_{S_2^2}^2 + \rho^2 dz d\bar{z}, \quad (2.61)$$

$$F_1 = f(z, \bar{z}), \quad F_5 = u \wedge \text{vol}_{S_1^2} \wedge \text{vol}_{S_2^2}, \quad (2.62)$$

$$F_3 = \sum_{i=1}^2 v_i \wedge \text{vol}_{S_i^2}, \quad H = \sum_{i=1}^2 w_i \wedge \text{vol}_{S_1^2}. \quad (2.63)$$

We decided to introduce a complex coordinate z on Σ , whose metric can be always put in warped diagonal form; the functions A, Δ_i, ρ depend on z, \bar{z} only, while v_i, w_i and u are one-forms on Σ . The exact functional dependence of such functions and one-forms in order to solve BPS equations is not relevant for us. What is really important is that all the quantities can be specified in terms of a couple of arbitrary harmonic functions, $\mathcal{A}_i(z)$, on the Riemann surface. If the harmonics are smooth, Σ must have the topology of the strip, $\mathbb{R} \times \text{Interval}$ with coordinates (y, x) , and the ten-dimensional space asymptote to $\text{AdS}_5 \times S^5$ for $y \rightarrow \pm\infty$; the dilaton has two different asymptotic values $\phi_\infty^{(\pm)}$ and thus the solution is actually a Janus solution. On the field theory side, this means that such a solution is dual to $\mathcal{N} = 4$ SYM in four dimensions with coupling constant jumping across an interface. However, the harmonic functions can also have singularities. A first kind of singularity can be introduced at points sitting on the two boundaries of the strip, as we illustrate in the following picture:



We represented the singularities with dots; the singular behavior close to the upper side of the strip signals the presence of a D5-brane, while the poles on the other boundary of the strip are NS5 singularities. However, none of these two kinds of singularities can change the behavior at $y \rightarrow \infty$ and we only obtained a different Janus solution. With an appropriate choice of \mathcal{A}_i , we can still add two D3 singularities at infinity. In this way, the internal space has the topology of the six-dimensional ball, $\mathcal{B}_6 \sim S^5 \times I$ with I an interval. The backgrounds built in this way can be put in one-to-one correspondence with $\mathcal{N} = 4$ linear quivers

in three-dimensions. In figure (2.65), we provide a pictorial representation of the surface Σ built in this way.



It must be stressed that explicit insertion of D3 branes in the background is not the unique way to obtain a compact internal manifold M_6 . In fact, let us consider a choice of harmonics periodic in y with period T :

$$\mathcal{A}_i(y) = \mathcal{A}_i(y + T). \quad (2.66)$$

This implies that we can quotient the strip with respect to the shift symmetry $y \rightarrow y + T$, performing the following identification of coordinates:

$$(y, x) \equiv (y + T, x). \quad (2.67)$$

We can also imagine to cut the strip at given reference points y_0 and $y_0 + T$ and gluing together the cut edges. Σ has now the topology of the annulus, as depicted in figure (2.68).

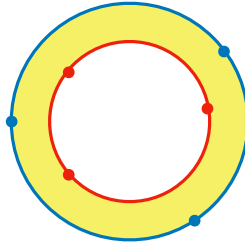

The last kind of backgrounds we have presented are dual to a different class of theories, *i.e.* $\mathcal{N} = 4$ circular quivers. Similarly to the supergravity construction, we can imagine to take a linear quiver with external nodes of equal rank and identifying them. The most general circular quiver is represented in (2.69).

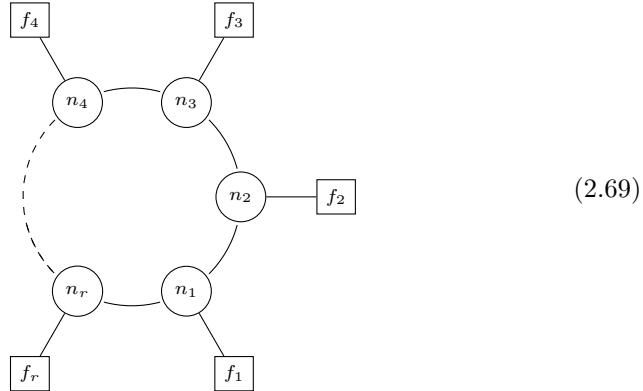

Chapter 3

S-duality walls

3.1 Gaiotto-Witten construction

Up to now, we considered brane configurations without really caring about the physics of brane intersections, except in rare cases as S-rule. In general, whenever a brane has an endpoint, rich and interesting physics arises. Let us consider, for instance, a semi-infinite D3-brane; it spans directions as in (2.52), but now it extends along $x^6 > 0$ only. Since an endpoint occurs, we must specify some boundary conditions and we would like to impose them in such a way to preserve some supersymmetry. At low energy, the brane dynamics can be usually traded for the dynamics of some quantum field theory living on the worldvolume; in the case at hand, it is well known that small fluctuations of a stack of N D3-branes admit a description in terms of 4d $SU(N)$ $\mathcal{N} = 4$ SYM living on the worldvolume. The bosonic content consists of a $SU(N)$ vector A_M with $M = 0, 1, 2, 3$ and six real scalars rotated by $SO(6)$ R-symmetry. The scalars can be collected into two sets \mathbf{W} and \mathbf{Z} describing the fluctuations of the brane in $\mathbf{w} = \{x^3, x^4, x^5\}$ and $\mathbf{z} = \{x^7, x^8, x^9\}$ directions. Observe that the splitting of the coordinates fits an eventual breaking of R-symmetry down to $SO(3) \times SO(3)$. In what follows, it is convenient to define $t = x^6$ and to perform the splitting $A_M = \{A_\mu, A_3\}$ with $\mu = 0, 1, 2$. The scalars and the vectors depend on both x^μ and t but we need to specify boundary conditions as $t \rightarrow 0$. A way to preserve half of supercharges is imposing usual Neumann and Dirichlet boundary conditions on the effective 3d hypermultiplet $\{A_3, \mathbf{Z}\}$ and 3d vector multiplet $\{A_\mu, \mathbf{W}\}$. The two multiplets cannot have equal boundary behavior: if $\{A_3, \mathbf{Z}\}$ obeys Neumann boundary condition, then $\{A_\mu, \mathbf{W}\}$ has Dirichlet ones, *i.e.* vanishes at $t = 0$. We will refer to this configuration as D5-like boundary conditions; vice-versa, we will have a NS5-like boundary conditions. Besides those two cases, more complicated situations can occur. As an example, D5-like conditions can be modified as follows:

$$(\partial_t - iA_3)\mathbf{Z} + \mathbf{Z} \times \mathbf{Z} = 0, \quad (3.1)$$

$$(\partial_t - iA_3)\mathbf{W} = [\mathbf{W}, \mathbf{W}] = [\mathbf{Z}, \mathbf{W}] = 0, \quad (3.2)$$

where we introduced the vector product $(\mathbf{Z} \times \mathbf{Z})^i = \epsilon^{ijk}[Z_j, Z_k]$. We can think the brane degrees of freedom along the \mathbf{w} directions as frozen. \mathbf{Z} can assume, instead, a non-trivial profile depending on the solution to (3.1). These equations

are called Nahm equations and they have been extensively studied in literature. A class of solutions is of the form:

$$Z^i = \frac{t^i}{y} + o(y), \quad (3.3)$$

where t^i are matrices forming a (reducible) $\mathfrak{su}(2)$ representation embedded in $\mathfrak{su}(N)$. As we learnt in section 2.4, each embedding can be described in terms of a Young tableaux ρ . From a brane perspective, we can think the solution (3.3) in the following way: as the D3-branes approach to $y = 0$, they start opening in the \mathbf{w} directions, “polarizing” into r concentric stacks of D5-branes, with r number of rows in ρ . An artist’s impression of such situation is illustrated in (3.4). This kind of brane dynamics is similar to the Myers effect described in [57].

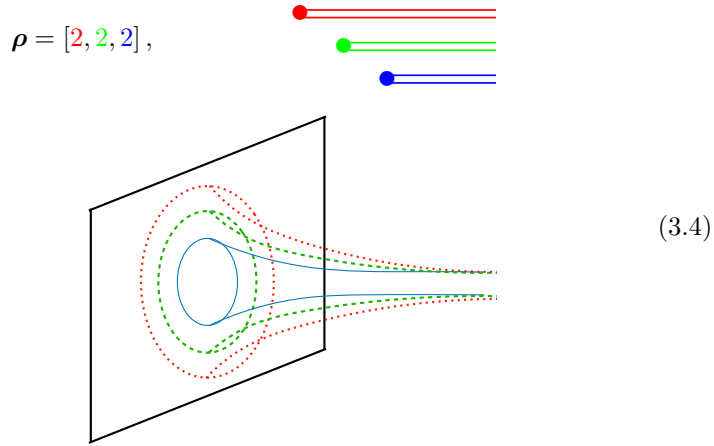

Understanding the effective three-dimensional field theory arising from this kind of configurations is not obvious. One reason is that the gauge group is broken down to the commutant of ρ in $\mathfrak{su}(N)$ and the way the boundary theory couples to the original 4d theory is not quite clear. S-duality helps to address this problem; in fact, we can dualize the brane setup in (3.4) in order to get a new system involving NS5s only:

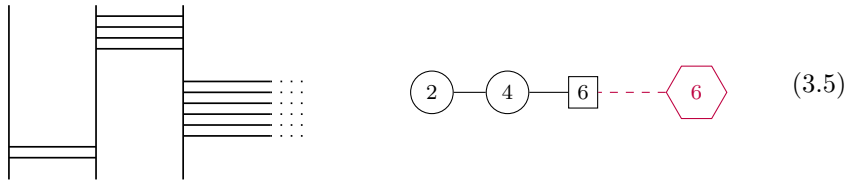

In (3.5), the D5-branes are traded for NS5s and we obtained a usual linear quiver. 4d $SU(6)\mathcal{N} = 4$ SYM is represented by an hexagonal purple node and its coupling to the purely 3d boundary theory is represented by a purple dashed line. This coupling is nothing but the usual minimal coupling of the $SU(6)$ flavor current to the bulk gauge field. The 4d coupling constant is considered finite, even if semi-infinite branes are usually interpreted as flavors. Freezing out the 4d gauge symmetry theory can be obtained by ending the semi-infinite D3-branes

on additional D5s. In fact, the vector multiplet must now obey Dirichlet and Neumann boundary conditions at the same time.

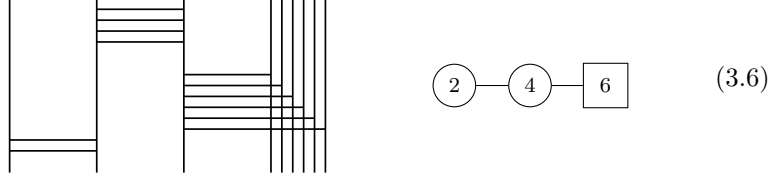

In general, understanding boundary conditions for D3-branes, or equivalently for the worldvolume four-dimensional theory, is of primary interest. For this reason, it is better to address a more systematic study by means of examples of growing complexity. Let us start with a single D3-brane with NS5-like boundary conditions, completely freezing $\{A_3, \mathbf{Z}\}$. We can couple the bulk theory to n additional hypermultiplets on the boundary by inserting n D5s not serving as endpoints. The new setup is illustrated in (3.7).

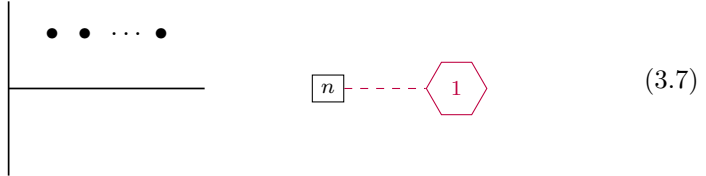

Again, in (3.7) we make a clear distinction between the boundary theory (n free hyper) and the bulk SYM theory; the coupling, represented by the purple dashed line, is the usual minimal coupling if we can think the hypers to possess charge 1 under the bulk gauge symmetry. In order to investigate the dual D5-like boundary conditions, we can simply S-dualize the previous configuration. Let us stress that S-duality in this context cannot be identified with mirror symmetry, that is a purely three-dimensional transformation: in fact, we also have a bulk 4d theory to take into account. The S-dual of (3.7) consists of n NS5 brane, a D5 and a semi-infinite D3:

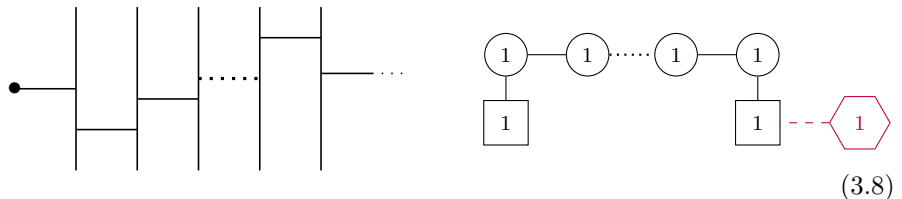

The brane system dual to the boundary theory in (3.10) can be built just by ending the n semi-infinite D3s on n additional D4s. Knowledge of the brane system allows us to construct the mirror companion of the 3d boundary theory:

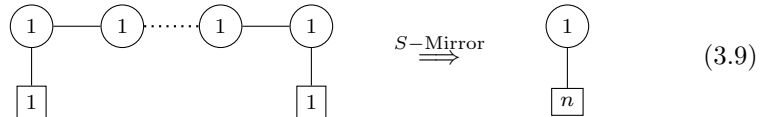

The mirror of (3.10) resembles something: this is nothing but the initial boundary n free hypermultiplets now coupled to a purely three-dimensional vector multiplet. Finally, instead of coupling the bulk theory to a flavor hypermultiplet as in (3.7), we can couple it to the mirror theory on the right of (3.9).

Because we are performing a mirror transformation, this coupling cannot occur on the Higgs branch¹ but we need to gauge a Coulomb global symmetry instead. We already know which symmetry lives on the Coulomb branch, topological symmetry, whose current is the field strength of the $U(1)$ connection. We can thus couple minimally the bulk SYM and (3.9), providing a new description of the S-dual configuration of (3.7):

(3.10)

The minimal coupling between the 3d topological current and the 4d vector is nothing but the BF coupling $-\frac{1}{4\pi} \int A_{4d} \wedge dA_{3d}$. As we commented in section 2.4, this mixed Chern-Simons coupling can be thought of as theory on its own, even if empty, *i.e.* $T[U(1)]$.

Let us now consider a more involved example, two D3 branes with NS5-like boundary conditions and n additional D5-branes; This corresponds to $\mathcal{N} = 4$ SYM coupled to n boundary hypermultiplets:

(3.11)

In order to understand the S-dual D5-like boundary condition, we can simply dualize the setup (3.11) getting the following one:

(3.12)

Instead of considering the minimal coupling between the bulk theory and $SU(2)$ flavor symmetry on the Higgs branch as in (3.12), we can instead couple the bulk theory to Coulomb branch symmetries of the mirror boundary theory:

(3.13)

In (3.13), we denoted with a red octagon a $T[SU(2)]$ theory whose Higgs branch $SU(2)$ global symmetry has been gauged in order to be coupled to the original n

¹Meaning that we cannot gauge a symmetry rotating hypermultiplets.

free hypermultiplets. Finally, (3.12) admits the following equivalent description:

$$\boxed{n} \xrightarrow{\mathcal{H}} \text{Hexagon}(2) \xrightarrow{\mathcal{C}} \text{Hexagon}(2) \quad (3.14)$$

The gauging between the n free hypermultiplets and the bulk theory is now “mediated” by a $T[SU(2)]$ theory whose global symmetries has been gauged. The Coulomb $SU(2)$ factor has been minimally coupled to the original bulk theory while the Higgs $SU(2)$ factor is gauged and minimally coupled to the original n free hypermultiplets. Let us stress again that there does not exist a Lagrangian description of $T[SU(2)]$ that makes the whole $SU(2)^2$ global symmetry manifest. In fact, the Coulomb branch factor arises at low energy as result of an enhancement of the $U(1)$ topological symmetry. For this reason, we have to consider such coupling non-Lagrangian.

With the previous two examples at hand, we are ready to fully generalize the result. The starting point is a stack of N D3-branes with NS5-like boundary conditions and a number of D5s participating as flavors and not as endpoints; respect to the previous study cases, we admit the D3s to end in various way on a number of NS5s. This situation can be understood in an abstract way as a bulk $\mathcal{N} = 4$ SYM coupled to some boundary theory \mathcal{B} with $SU(N)$ global symmetry on his Higgs branch.

$$\text{Hexagon}(N) \text{---} \text{---} \text{---} \boxed{\mathcal{B}} \quad (3.15)$$

Applying S-duality to this general setup, we obtain the bulk theory to be coupled to Higgs global symmetry of a new boundary SCFT that we denotes as \mathcal{B}^\vee . Let us stress again the \mathcal{B}^\vee is not the mirror of \mathcal{B} because S-duality cannot be identified with mirror symmetry at this stage. A description of \mathcal{B}^\vee is not always at hand. However, we can now provide a way to bypass the problem: we can consider the bulk theory to be coupled to the Coulomb branch symmetry of the mirror theory, $\text{Mir}[\mathcal{B}^\vee] = \tilde{\mathcal{B}}^\vee$. The mirror $\tilde{\mathcal{B}}^\vee$ can be built generalizing what we observed in the previous examples: it is nothing but the original \mathcal{B} coupled to the Higgs symmetry of $T[SU(N)]$, $\mathcal{B} \times_{\mathcal{H}} T[SU(N)]$.

$$\text{Mir} \left[\boxed{\mathcal{B}^\vee} \right] = \begin{array}{c} \boxed{\mathcal{B}} \\ | \\ \mathcal{H} \\ \text{Hexagon}(N) \end{array} \quad (3.16)$$

Finally, the S-dual of (3.15) consists of $T[SU(N)]$ coupled on the Higgs branch to \mathcal{B} and on the Coulomb branch to the bulk theory. Again, we stress that gauging the Coulomb branch $SU(N)$ global symmetry makes this kind of coupling non-Lagrangian. A summary is illustrated in (3.17), where \mathcal{C} and \mathcal{B} denote which symmetry factor of $T[SU(N)]$ has been gauged.

$$\begin{array}{c} \text{Hexagon}(N) \\ | \\ \text{---} \text{---} \text{---} \\ | \\ \boxed{\mathcal{B}} \end{array} \xrightarrow{\text{S-dual}} \begin{array}{c} \text{Hexagon}(N) \\ | \\ \text{---} \text{---} \text{---} \\ | \\ \boxed{\mathcal{B}^\vee} \end{array} \xrightarrow{\text{Mirror}} \begin{array}{c} \text{Hexagon}(N) \\ | \\ \text{---} \text{---} \text{---} \\ | \\ \boxed{\tilde{\mathcal{B}}^\vee} \end{array} = \begin{array}{c} \text{Hexagon}(N) \\ | \\ \text{---} \text{---} \text{---} \\ | \\ \text{Hexagon}(N) \xrightarrow{\mathcal{H}} \boxed{\mathcal{B}} \end{array} \quad (3.17)$$

The coupling between two theories by means of a $T[SU(N)]$ theory will be denoted in the following as:

$$\boxed{\mathcal{B}} \text{---}^{T[SU(N)]} \text{---} \boxed{\mathcal{B}'} \quad (3.18)$$

It must be pointed out that, up to now, we only assumed the presence of NS5-like boundary conditions. Nonetheless, more general constraints involving D5-like boundary conditions are possible. In such cases, we need to deal with Nahm pole singularities for worldvolume fields. Following the most general story in [15], it is always possible to trade exotic boundary conditions in favor of a coupling to some T_{ρ}^{σ} theory, generalizing our previous analysis.

3.2 S-fold theories

Using the Gaiotto-Witten construction, it is possible to build a new class of three-dimensional $\mathcal{N} = 4$ SCFTs that are object of study of this thesis. Let us start considering the following field theory setup in four dimensions $\{x^0, x^1, x^2, t\}$: in the region $t < 0$ physics is described by $\mathcal{N} = 4$ SYM with gauge group $SU(N)$ and coupling constant g_- while the region $t > 0$ differs for a different choice g_+ . The two constants are chosen in such a way the left region to be at weak coupling and the right one to be strong coupling. Usually, it is also common to think the coupling constant as a smooth function $g(t)$ sharpened on $t = 0$ and with asymptotic values g_{\pm} . Such a setup is usually named Janus configuration. It can be thought to be engineered by two stacks of semi-infinite D3-branes spanning respectively $y > 0$ and $y < 0$ and both ending at an $t = 0$ interface.

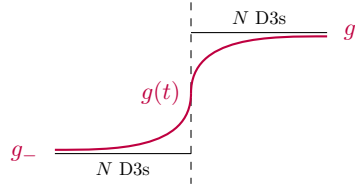

(3.19)

In order to deal with the strongly coupled sector, we can use Gaiotto-Witten proposal. First we perform an S-duality transformation in the $t > 0$ region. What we land on is $\mathcal{N} = 4$ SYM weakly coupled to some boundary 3d theory with $SU(N)$ symmetry on its Higgs branch. Following the steps of section 3.1, we can expect the $t > 0$ region to be described by $\mathcal{N} = 4$ SYM minimally coupled to boundary theory, $T[SU(N)]$, gauging the Coulomb $SU(N)$ factor. In this sense, we can think of $T[SU(N)]$ as the theory living on a duality wall, emerging because of the effect of a local S-duality transformation. We can reduce to a pure three-dimensional configuration if we end the semi-infinite D3-branes on some NS5s: in fact, the new boundary conditions kill the fluctuations of the fields depending on t . The new configuration can be represented as follows:

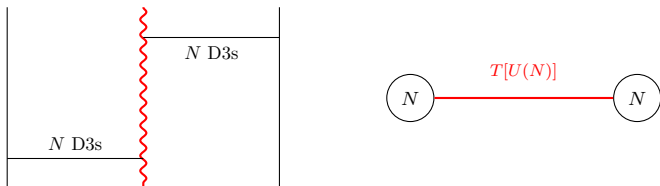

(3.20)

The red wiggly line in the brane system (3.20) represents an interface passing through the system undergoes an S-duality transformation: we will call such interface an S-duality wall or “S-fold”. Observe that the duality transformation is only local and is not implemented on the whole space. We used a straight red line to denote the associated coupling to $T[U(N)]$. Let us stress that, once we reduce to the 3d modes only, we are considering a slightly different coupling $T[U(N)]$ instead of $T[SU(N)]$. One could expect this noticing that in three-dimensions, quivers dual to Hanany-Witten setups have gauge symmetry made of $U(N)$ factors. Let us also remind that $T[U(N)]$ is actually a product theory:

$$T[U(N)] = T[U(1)] \times T[SU(N)], \quad (3.21)$$

where $T[U(1)]$ has been already introduced in section 3.1 and section 2.4. Because $T[U(1)]$ will play a fundamental role for us, let us write the exact form in $\mathcal{N} = 2$ language of the BF coupling induced on two abelian vector multiplets $\{V_i, \Phi_i\}$ by a this almost empty theory (see for instance [58]):

$$\mathcal{L}_{\text{BF}T[U(1)]} = -\frac{1}{4\pi} \int d^3x d^2\theta d^2\bar{\theta} (\Sigma_1 V_2 + \Sigma_2 V_1) + \frac{1}{2\pi} \int d^3x d^2\theta \Phi_1 \Phi_2 + \text{c.c.} \quad (3.22)$$

where V, Φ and $\Sigma = iD\bar{D}V$ respectively denote the $\mathcal{N} = 2$ vector multiplet, the adjoint chiral multiplet and the linear multiplet of an $\mathcal{N} = 4$ vector multiplet. Let us observe that up to now we assumed that the two $U(N)$ flavor symmetries of a T-theory are naively identified with the gauge groups of the adjacent nodes. As pointed out in [19], there are actually two possibilities for coupling the $U(N)$ flavor symmetry to the $U(N)$ gauge field on each side, namely $U(N)_+ = \text{diag}(U(N) \times U(N))$ or $U(N)_- = \text{diag}(U(N) \times U(N)^\dagger)$. For $T[U(N)]$, the gauging is chosen to be $U(N)_+$ on both sides, whereas we define as $\overline{T[U(N)]}$ the case in which the gauging is chosen to be $U(N)_+$ on one side and $U(N)_-$ on the other side.

The configuration shown in (3.20) is linear. This means that we can make all the branes pass the interface S-dualizing them, reaching a new system where no coupling to $T[U(N)]$ (T-link in what follows) is involved. Let us consider, instead, a circular brane system as the follows:

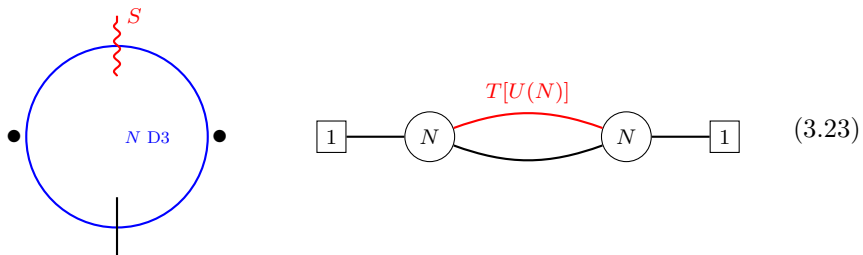

In this case, moving a brane across the S-fold only produces a new configuration equivalent to the original one. Each of these systems contains a T-link coupling two adjacent nodes: circular models are really non-trivial. We expect such theories to flow to a super-conformal fixed point at low energy. We call this class of super-conformal theories S-fold SCFTs.

As a last comment, let us observe that the number of supercharges preserved by S-fold models is not obvious. In fact, since we are gauging at the same time

Coulomb and Higgs symmetries of $T[U(N)]$, the two factors of R-symmetry, $SU(2)_C$ and $SU(2)_H$, must be identified. R-symmetry is naively broken down to a diagonal $SU(2)$ factor and one could be tempted to claim that now only $\mathcal{N} = 3$ supersymmetry is preserved. This claim can be considered to be true in the cases we have presented up now. However, we will see how non-trivial Chern-Simons levels can modify the previous statement.

3.3 Supergravity realization

One of the features that makes S-fold SCFTs interesting is the presence of a holographic dual, first studied in [19, 20]. As the field theory construction suggest, the starting point is the class of $\mathcal{N} = 4$ backgrounds we presented in section 2.6. Let us recall the main features. The Type-IIB solutions have the form $\text{AdS}_4 \times S^2 \times S^2 \times \Sigma$, where Σ is a Riemann surface with the topology of the strip. The solutions are fully characterized by a choice of two harmonic functions $\mathcal{A}_i(z)$ on Σ and in particular eventual singularities are of first relevance in describing the backgrounds. We presented three kind of singularities, signaling presence of D3, D5 and NS5 branes. We observed that whenever the harmonic functions \mathcal{A}_i are periodic, we can cut and glue the strip at two sides, obtaining the holographic duals of circular quivers. In that case, we exploited the shift symmetry $\mathcal{A}_i(y) = \mathcal{A}_i(y + T)$ where y is the non-compact direction of the strip and T is a given period. However, this is not the most general gluing procedure one can imagine. In fact, we can think to use the fact that Type-IIB supergravity possesses an $SL(2, \mathbb{Z})$ action on it. Such transformations rotates the axio-dilaton $\tau = C_0 + ie^{-\phi}$ and the complexified three-form $\mathcal{G}_3 = e^{\phi/2}F_3 - ie^{-i\phi/2}H$. The five-form flux and the metric are instead invariant. Because the solution is specified by metric and fluxes, we can focus on their orbits under $SL(2, \mathbb{Z})$. We can imagine to pick a couple of harmonic functions such that²:

$$\tau(y + T) = M \tau(y), \quad (3.24)$$

where M is an element in $SL(2, \mathbb{Z})$. Elements of $SL(2, \mathbb{Z})$ can be always written as combination of two generators:

$$S = \begin{pmatrix} 0 & -1 \\ 1 & 0 \end{pmatrix}, \quad T = \begin{pmatrix} 1 & 0 \\ 0 & 1 \end{pmatrix}. \quad (3.25)$$

The effects of these transformations are better understood in terms of brane systems involving webs of $\binom{p}{q}$ 5-branes. In our conventions, $\binom{1}{0}$ is an NS5 brane while $\binom{0}{1}$ is a D5. As we know S swaps D5s and NS5s while the effect of T^k is quite different: it leaves D5-branes invariant and rotates NS5s as follows

$$T^k \binom{1}{0} = \begin{pmatrix} 1 & 0 \\ k & 1 \end{pmatrix} \binom{1}{0} = \binom{1}{k}. \quad (3.26)$$

A $\binom{1}{k}$ brane turns on Chern-Simons levels k and $-k$ on the left and right node respectively.

²An appropriate $SL(2, \mathbb{Z})$ element M' must rotate at the same time also the complex 3-form flux.

Let us assume that the choice of harmonic functions in our background is such that:

$$\tau(y+T) = S\tau(y). \quad (3.27)$$

We can perform a quotient of the strip with respect to the T -shift symmetry and S -transformation; this means that we make an identification of points on Σ , $(y, x) \sim (y+T, x)$, such that the background is left invariant up to an S -transformation. In other words, the system undergoes an S -duality transformation when passing through the cut. In order to get an honest supergravity solution, a third transformation must be performed at the cut: we need an antipodal identification of the compact coordinate x . We end up with a Riemann surface with the topology of the Moebius strip and a non-trivial monodromy under $SL(2, \mathbb{Z})$. The gluing procedure is illustrated in (3.28).

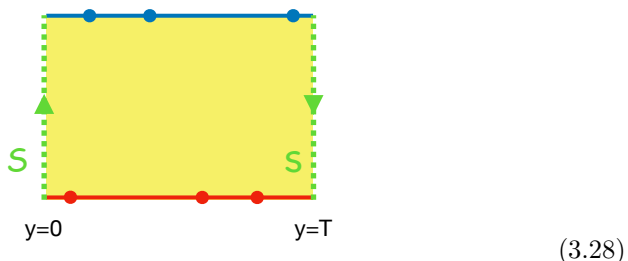

The cut can be understood as an S -interface in a brane system while the antipodal identification of the compact coordinate consists of a flip of coordinate at the S -interface $(x^{3,4,5}, x^{7,8,9}) \rightarrow (x^{7,8,9}, -x^{3,4,5})$. Because of such identification, we expect the two $SU(2)$ factors of R -symmetry to be broken to the diagonal $SU(2)$ subgroup and only $\mathcal{N} = 3$ supersymmetry to be preserved, as expected. We will prefer to call this interface “ S -flip”.

Another possibility is:

$$\tau(y+T) = J_k \tau(y), \quad J_k = -ST^k = \begin{pmatrix} k & 1 \\ -1 & 0 \end{pmatrix}. \quad (3.29)$$

This time, in order to obtain a good supergravity solution we do not need any antipodal identification and the R -symmetry group is left unbroken. This suggests that the class of SCFTs dual to this background preserve all the initial supercharges. This can sound strange, since the action of the element T turns on CS a level, explicitly breaking supersymmetry at Lagrangian level. We identify the points $(y, x) \sim (y+T, x)$ up to a J_k transformation. We obtain a new J_k -interface that we will refer to as J -fold. Observe that passing through the J -fold the background, or equivalently the brane system, undergoes an S -duality transformation, signaling the presence of a T -link coupling two adjacent nodes, and a T^k transformation, that has the effect to turn on a CS level k for the left T -linked gauge nodes. The choice of the left node is purely conventional and it will be kept all along the thesis. Together with J_k , we can also consider J_k^{-1} : it couples two adjacent gauge nodes by means of $\overline{T[U(N)]}$ and turns on a CS

level $-k$ on the right node. The J_k cut is represented in (3.30).

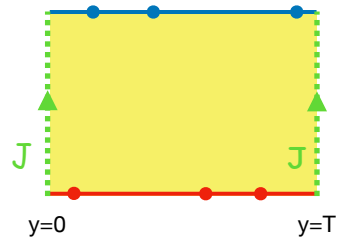

(3.30)

Part II

Original part

Chapter 4

The moduli spaces of S-fold CFTs

4.1 Models with one S-flip

In this section we want to study models dual to circular Hanany-Witten configurations where an S-flip surface has been inserted. From a quantum field theory perspective, the dual models consist of circular quivers where a couple of adjacent gauge nodes is connected by a $T[U(N)]$ theory whose $SU(N)^2$ global symmetry has been gauged. Moreover, let us stress that no Chern-Simons coupling are included. Since the T-link is by definition a non-Lagrangian coupling, we need an *ad hoc* proposal for the moduli space of S-flip models to be tested against mirror symmetry. This means that, given two theories A and B related by S-duality, our proposal must satisfy the condition $\mathcal{H}_A = \mathcal{C}_B$ and $\mathcal{H}_B = \mathcal{C}_A$. Let us summarize the main results. We propose that the Higgs branch can be computed as an hyperkähler quotient of a given initial quaternionic manifold \mathcal{M} . Each cone of $T[U(N)]$ is described by the maximal nilpotent orbit of $T[SU(N)]$ while each hypermultiplet defines the quaternionic space $\mathbb{C}^{2\dim\mathcal{R}}$ where \mathcal{R} is the representation under which the multiplet transforms. The product of such spaces defines the parent manifold \mathcal{M} . The hyperkähler quotient is nothing but the gauging of some symmetries do to the presence of vector multiplets. At geometric level, this means the we need to identify all points on \mathcal{M} that can be related by a gauge transformation. The Higgs branch of a generic S-flip model thus admits a generic form:

$$\mathcal{H}_{\text{S-flip}} = \frac{\mathcal{N}_{SU(N)} \times \mathcal{N}_{SU(N)} \times \prod_{I=1} \mathbb{C}^{2\dim\mathcal{R}_I}}{G}, \quad (4.1)$$

where I runs over the whole set of hypermultiplets and G is the total gauge group. (4.1) can be translated in the language of Hilbert series. Consistency with mirror symmetry suggests the Coulomb branch of an S-flip theory can be also computed in a systematic way. We impose that the scalars in the vector multiplets connected by the T-link are frozen and thus cannot participate to the Coulomb branch. Using this prescription, we remain with a *wreck* quiver where the $T[U(N)]$ theory disappeared and the linked nodes behaves like usual $SU(N)$ flavor hypermultiplets. We claim that the Coulomb branch of the wreck quiver

coincides with the one of the initial S-flip model. We will refer to this prescription as freezing rule. Observe that the freezing rule has a natural interpretation at the level of brane configuration. In fact, expectation values of scalars sitting in vector multiplets are put in correspondence with the positions of D3s along the directions spanned by NS5 branes. The fact the such scalars get frozen, means that D3 branes ending on an S-fold are stacked at fixed position: observe this is a non-trivial prediction about brane dynamics. In the rest of the section, we will test the conjecture in various examples.

4.1.1 Flavored affine A_1 quivers

The first example we want to present is the following: Let us consider the following brane set-up and the following theory.

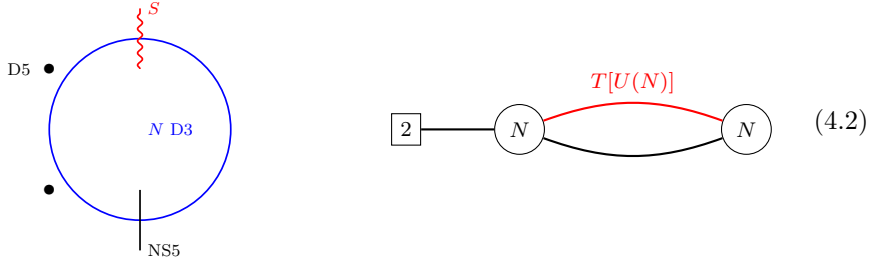

We will refer to this model as a flavored affine A_1 model, because of the particular pattern of the gauge nodes. As first example, we will study it in full detail. Let us start analyzing the Higgs branch of such model. First of all, we can easily compute the (quaternionic) dimension of such space, using the general prescription presented in section 2.3. The only non-trivial information that we need is the dimension of the maximal nilpotent orbit $\mathcal{N}_{SU(N)}$. However, it can be computed using the quiver description (2.50) of $T[U(N)]$:

$$\dim_{\mathbb{H}} \mathcal{H} [T[U(N)]] = \dim_{\mathbb{H}} \mathcal{C} [T[U(N)]] = \frac{1}{2} N(N-1). \quad (4.3)$$

With this information at hand, we can conclude that:

$$\dim_{\mathbb{H}} \mathcal{H}_{(4.2)} = N(N-1) + N^2 + 2N - N^2 - N^2 = N, \quad (4.4)$$

where $2N$ is the contribution of flavor hypermultiplets, $+N^2$ comes from bi-fundamental matter and the the gauge vectors are taken into account by means of the two negative contributions $-N^2$. $\mathcal{H}_{(4.2)}$ also admits a formal description as in (4.1). Denoting the three gauge groups in (4.2) as $U(N)_i$, $i = 1, 2$, we claim the following to hold:

$$\mathcal{H}_{(4.2)} = \frac{\mathcal{H}([U(2)] - [U(N)_1]) \times \mathcal{N}_{SU(N)_1} \times \mathcal{N}_{SU(N)_2} \times \mathcal{H}([U(N)_1] - [U(N)_2])}{U(N)_1 \times U(N)_2}, \quad (4.5)$$

Here $\mathcal{H}([U(2)] - [U(N)_1])$ is nothing but the flat hyperkähler space \mathbb{C}^{4N} parametrized by the VEVs of the flavor hypermultiplets, while bi-fundamental hypers enter the Higgs branch as $\mathcal{H}([U(N)_1] - [U(N)_2]) = \mathbb{C}^{2N^2}$. Observe that in the numerator of (4.5) we considered all hypers as free: gauging of $SU(N)^2$ global symmetries is taken into account by means of the quotient operation. A more

detailed and quantitative description of the hyperkähler space (4.5) can be done using Hilbert series. Let us review the main rules:

- A hypermultiplet, with chiral components (Q, \tilde{Q}) transforming in some representation $(\mathcal{R}, \overline{\mathcal{R}})$ of global and gauge symmetry group G , contributes to the Hilbert series in the following way¹:

$$H_{(Q, \tilde{Q})} = PE [t(\chi_{\mathcal{R}}^G(\mathbf{x}) + \chi_{\overline{\mathcal{R}}}^G(\mathbf{x}))], \quad (4.6)$$

where $\chi_{\mathcal{R}}$ is the character of the representation \mathcal{R} of G and \mathbf{x} collectively denotes all possible fugacities for global and gauge symmetries; t is the R-symmetry fugacity.

- The Hilbert series describing the maximal nilpotent orbit of $SU(N)$ is explicitly known [47, 53]:

$$H[\mathcal{N}_{SU(N)}](t, \mathbf{x}) = \left[\prod_{j=2}^N (1 - t^{2j}) \right] \times PE [t^2 \chi_{\mathbf{adj}}^{SU(N)}(\mathbf{x})], \quad (4.7)$$

Here, \mathbf{x} are fugacity for the $SU(N)$ global symmetry group.

- The quotient operation, *i.e.* gauging, can be performed integrating over the gauge group fugacities:

$$\text{Gauging: } \int d\mu_G(\mathbf{z}), \quad (4.8)$$

where $\mu_G(\mathbf{z})$ is the Haar measure of the gauge group. For instance, in the case $G = U(N)$ we have:

$$\int d\mu_{U(N)}(\mathbf{z}) = \left(\prod_{i=1}^N \oint_{|z_i|=1} \frac{dz_i}{2\pi i z_i} \right) \prod_{1 \leq i < j \leq N} \left(1 - \frac{z_i}{z_j} \right). \quad (4.9)$$

The adjoint chiral multiplets Φ contribute as following:

$$H_{\Phi} = PE [-t^2 \chi_{\mathbf{adj}}^G(\mathbf{z})]. \quad (4.10)$$

Such contribution is usually also interpreted as implementing the constraints on gauge-invariant generators imposed by F terms (2.32). Observe, in fact, that (2.35) sets to zero a triple of operators with R-charge 2 and transforming in the adjoint representation of the gauge group. The same information is encoded in (4.10). Every time we want to impose a constraint setting to zero an R-charge r operator transforming in some representation \mathcal{R} of the gauge group, we can add to the integrand of the Hilbert series a contribution $PE[-t^r \chi_{\mathcal{R}}(\mathbf{z}, \mathbf{x})]$, where \mathbf{z} are gauge fugacities and \mathbf{x} possible global symmetry fugacities; the minus in the PE always signals a constraint.

¹The plethystic exponential (PE) of a multivariate function $f(x_1, x_2, \dots, x_n)$ such that $f(0, 0, \dots, 0) = 0$ is defined as $PE[f(x_1, x_2, \dots, x_n)] = \exp(\sum_{k=1}^{\infty} \frac{1}{k} f(x_1^k, x_2^k, \dots, x_n^k))$.

Using these ingredients, we can compute:

$$\begin{aligned}
H[\mathcal{H}_{(4.2)}](t, x) &= \\
&\int d\mu_{U(N)}(\mathbf{u}) \int d\mu_{U(N)}(\mathbf{w}) \times \text{PE} [-t^2 \chi_{\text{adj}}(\mathbf{u}) - t^2 \chi_{\text{adj}}(\mathbf{w})] \\
&\times \text{PE} [t(x + x^{-1}) \{ \chi_{\text{fund}}(\mathbf{u}) + \chi_{\overline{\text{fund}}}(\mathbf{u}) \}] \\
&\times H[\mathcal{N}_{SU(N)}](t, \mathbf{u}) H[\mathcal{N}_{SU(N)}](t, \mathbf{w}) \\
&\times \text{PE} [t \chi_{\text{fund}}(\mathbf{u}) \chi_{\overline{\text{fund}}}(\mathbf{w}) + t \chi_{\text{fund}}(\mathbf{w}) \chi_{\overline{\text{fund}}}(\mathbf{u})] ,
\end{aligned} \tag{4.11}$$

where \mathbf{u} and \mathbf{w} are $SU(N)$ fugacities for the left and right node in (4.2) respectively and x is the fugacity for the $SU(2)$ flavor symmetry; all the characters χ are understood as $U(N)$ characters while $x + x^{-1} = \chi_{\text{fund}}^{SU(2)} = \chi_{\overline{\text{fund}}}^{SU(2)}$. Such integral can be evaluated analytically:

$$H[\mathcal{H}_{(4.2)}](t, x) = \text{PE} \left[\chi_{\text{adj}}^{SU(2)}(x) \sum_{j=1}^N t^{2j} - \sum_{j=1}^N t^{2N+2j} \right] , \tag{4.12}$$

where

$$\chi_{\text{adj}}^{SU(2)}(x) = x^2 + 1 + x^{-2} . \tag{4.13}$$

This provides a rigorous description of the hyperkähler space (4.5). We can immediately recognize that such space possesses $SU(2)$ isometries, realized as flavor symmetry in (4.2); this is in agreement with the general expectation for Higgs branch global symmetries. Let us observe that (4.12) also tells us that the Higgs branch of (4.2) is generated by N chiral operators of dimension t^{2j} , $j = 1, \dots, N$ and transforming in the adjoint representation of the global symmetry group. However, N constraints must be imposed on such generators, as we can read from the negative contributions in (4.12). Thus, we can claim to the branch to be generated by $\dim(SU(2))N - N = 2N$ complex independent generators only and the quaternionic dimension of $\mathcal{H}_{(4.2)}$ to be N , in perfect agreement with (4.4).

We can now switch to the Coulomb branch of (4.2). Since all the gauge nodes of the quiver are connected by a T-link, the conjectured freezing rule implies that the Coulomb branch must be actually empty:

$$\dim_{\mathbb{H}} \mathcal{C}_{(4.2)} = 0 . \tag{4.14}$$

This actually concludes the analysis of the moduli space of the flavored affine A_1 model. However, this highly non-trivial prediction must be tested against mirror symmetry. The S-dual theory of (4.2) is the following:

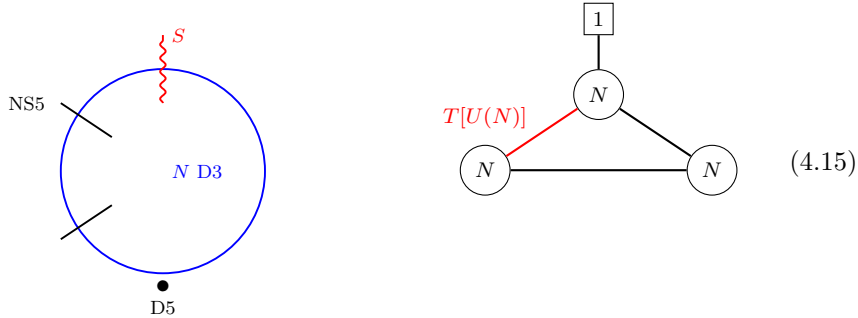

We can immediately compute the dimensions of Higgs and Coulomb branches, taking into account the general prescription we presented and the proposed freezing rule²:

$$\begin{aligned} \dim_{\mathbb{H}} \mathcal{H}_{(4.15)} &= N^2 + N^2 + N + 2 \left[\frac{1}{2}(N-1)N \right] - 3N^2 = 0, \\ \dim_{\mathbb{H}} \mathcal{C}_{(4.15)} &= N. \end{aligned} \quad (4.16)$$

This is in perfect agreement with the previous results in (4.4)-(4.14). Moreover, freezing rule states that:

$$\mathcal{C}_{(4.15)} = \mathcal{C} \left[\begin{array}{c} \circ \\ N \end{array} - \begin{array}{c} \square \\ 2N \end{array} \right], \quad (4.17)$$

because the linked nodes in (4.15) get frozen on the Coulomb branch. The Coulomb branch of $U(N)$ theory with $2N$ flavors possesses an $SU(2)$ isometry group, since the unique node is balanced. This is in perfect agreement with the global symmetries of $\mathcal{H}_{(4.2)}$. The Hilbert series of the Coulomb branch of $U(2)$ theory with $2N$ flavors is known in literature and using the results of [30] it is possible to see that:

$$H[\mathcal{C}_{(4.15)}] = H[\mathcal{H}_{(4.2)}]. \quad (4.18)$$

This completes the analysis of the flavored affine A_1 model, fully confirming the general proposal we made.

4.1.2 Quivers with a $T[U(N)]$ loop

A second example where testing the conjecture for S-flip model moduli space is the following:

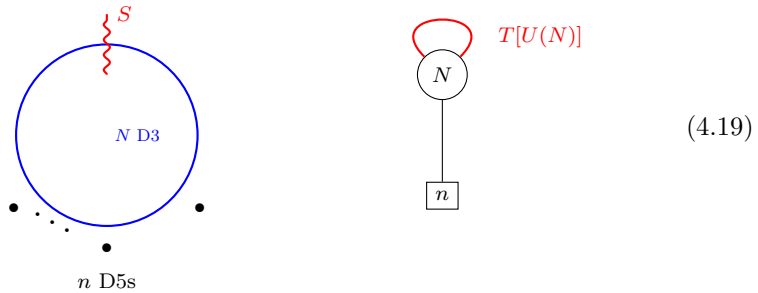

We will refer to it as model with a T-loop. Because we want to study its moduli space and check it against mirror symmetry, we can immediately write down the S-dual configuration of (4.19):

²Let us remind that the quaternionic dimension of the Coulomb branch can be identified with the rank of the total gauge group.

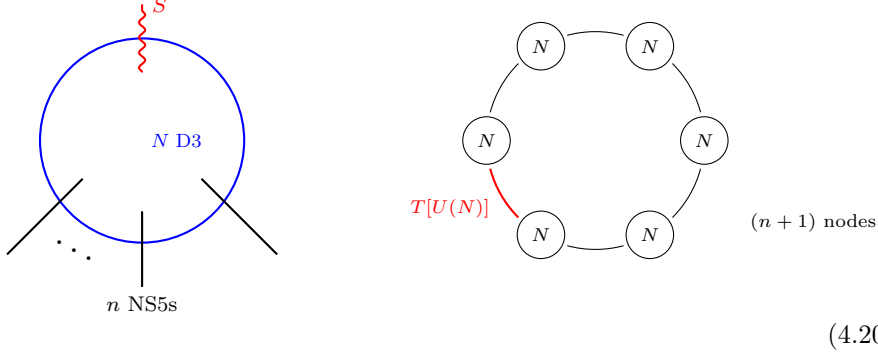

Let us start providing a formal description of Higgs branches as hyperkähler quotients:

$$\mathcal{H}_{(4.19)} = \frac{\mathcal{N}_{SU(N)} \times \mathcal{N}_{SU(N)} \times \mathcal{H}([U(N)] - [U(n)])}{U(N)}, \quad (4.21)$$

$$\mathcal{H}_{(4.20)} = \frac{\mathcal{N}_{SU(N)} \times \mathcal{N}_{SU(N)} \times \mathcal{H}[U(N) - U(N)]^n}{U(N)^{n+1}/U(1)^N}. \quad (4.22)$$

Observe that in (4.22) we have not performed the quotient with respect to the whole gauge group $U(N)^{n+1}$. This is due to the fact that on the Higgs branch the gauge group is not completely Higgsed but an abelian factor $U(1)^N$ survives (for a description of such phenomenon, see for instance [59]). Using the freezing rule, we can provide instead the effective description for Coulomb branches:

$$\mathcal{C}_{(4.19)} = \emptyset, \quad (4.23)$$

$$\mathcal{C}_{(4.20)} = \mathcal{C}\left[\underbrace{\square_N - \circ_N - \cdots - \circ_N - \square_N}_{(n-1) \text{ nodes}}\right]. \quad (4.24)$$

A first check that the proposed set of hyperkähler manifold provide good pairs of cones exchanged under mirror symmetry comes from counting of quaternionic dimensions:

$$\dim[\mathcal{H}_{(4.19)}] = N(N-1) + nN - N^2 = (n-1)N, \quad (4.25)$$

$$\dim[\mathcal{H}_{(4.20)}] = N(N-1) + nN - ((n+1)N^2 - N) = 0, \quad (4.26)$$

$$\dim[\mathcal{C}_{(4.19)}] = 0, \quad (4.27)$$

$$\dim[\mathcal{C}_{(4.20)}] = (n-1)N. \quad (4.28)$$

The quaternionic dimensions we found are completely in agreement with mirror symmetry. Observe that $\mathcal{H}_{(4.20)}$ and $\mathcal{C}_{(4.19)}$ are both empty and thus they trivially equal. What we need to check is that the two hyperkähler cones $\mathcal{C}_{(4.20)}$ and $\mathcal{H}_{(4.19)}$ are actually the same. This can be done, as before, computing their associated Hilbert series. However, we do not really need to compute them this time. In fact, using again mirror symmetry, one can observe that [60]:

$$\mathcal{C}\left[\underbrace{\square_N - \circ_N - \cdots - \circ_N - \square_N}_{(n-1) \text{ nodes}}\right] = \mathcal{H}\left[\underbrace{\circ_1 - \circ_2 - \cdots - \circ_{N-1} - \circ_N - \circ_{N-1} - \cdots - \circ_2 - \circ_1}_{\square_n}\right]. \quad (4.29)$$

Let now focus on the righthand side of (4.29): we can think it as the hyperkähler quotient of the following building blocks:

$$\mathcal{H}\left[\begin{array}{ccccccc} \circ & - & \circ & - & \cdots & - & \circ \\ 1 & & 2 & & & & N-1 \\ & & & & & & \circ \\ & & & & & & N \\ & & & & & & \circ \\ & & & & & & N-1 \\ & & & & & & \circ \\ & & & & & & 2 \\ & & & & & & \circ \\ & & & & & & 1 \end{array}\right] = \quad (4.30)$$

$$\left(\mathcal{H}\left[\begin{array}{ccccccc} \circ & - & \circ & - & \cdots & - & \circ \\ 1 & & 2 & & & & N-1 \\ & & & & & & \circ \\ & & & & & & N \\ & & & & & & \circ \\ & & & & & & N-1 \\ & & & & & & \circ \\ & & & & & & 2 \\ & & & & & & \circ \\ & & & & & & 1 \end{array}\right]^2 \times \mathcal{H}\left[\begin{array}{cc} \square & - \\ N & n \end{array}\right] \right) // U(N)$$

We immediately recognize two copies of $T[U(N)]$ so that we can also claim the following equality:

$$\mathcal{C}_{(4.20)} = \frac{\mathcal{N}_{SU(N)} \times \mathcal{N}_{SU(N)} \times \mathcal{H}([U(N)] - [U(n)])}{U(N)} = \mathcal{H}_{(4.19)}. \quad (4.31)$$

This completes the study of the moduli space of the T-loop model and again confirms the consistency of our conjecture with mirror symmetry.

4.2 Warm-up: Abelian theories with CS levels

Our proposal for moduli space of S-flip SCFTs is essentially based on an educated guess, suggested by the required consistency with mirror symmetry. Moreover, we only considered S-flip models, *i.e.* we chose to consider theories where all Chern-Simons levels are set to zero. In the following, we would like to generalize to models where Chern-Simons level are non-trivial and provide some more evidence about the freezing rule conjecture. From a brane perspective, we want to consider Hanany-Witten setups with n D3-branes on S^1 and one or more J-folds. Presence of Chern-Simons levels usually make the study of moduli space harder: in fact, the Coulomb branch is described in terms of both monopoles and mesons and taking into account their dynamics at the same time is not an easy task. For instance, there is no a generic prescription to take into account constraints imposed on gauge-invariant generators due to F and D terms (2.32)-(2.33)-(2.34). In some simple models, a full set of constraints can be computed using computational tools like Macaulay package. A particular class of models where F and D terms can be solved with simple algebraic computations is the class of Abelian models. Moreover, the S-fold SCFTs involving only Abelian nodes is suitable for our purpose since $T[U(1)]$ is a Lagrangian coupling and the theories can be studied in full generality. Before we enter into details with Abelian S-fold theories, it is better to warm up studying studying linear Abelian quivers: most features of their moduli space will extend to S-fold models. In this section we only study linear Abelian quivers with arbitrary Chern-Simons levels and without fundamental matter. Each model is specified by a vector of levels $\mathbf{k} = (k_1, \dots, k_n)$ where k_i is the Chern-Simons level of the i -th gauge node.³ We will start with an example and then we will consider the most general case and will provide a general description for moduli space. The study of Abelian linear quivers with Chern-Simons levels has been also addressed in [61].

³We denote the CS level by a subscript, for example $U(N)_k$ denotes a group $U(N)$ with CS level k . In a quiver node, we abbreviate this as N_k .

4.2.1 Example: $\mathbf{k} = (-1, +1, -1, +1)$

Consider the following gauge theory:

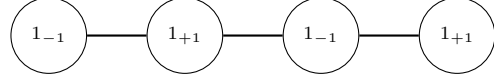

$$(4.32)$$

Here we assume $k > 0$ without loss of generality. Let us also show the same quiver in $\mathcal{N} = 2$ language, in order to fix the notation:

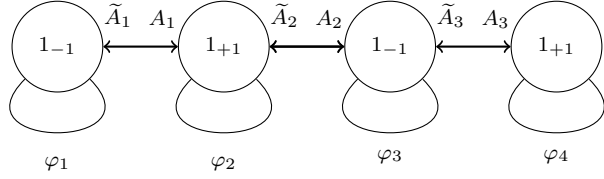

$$(4.33)$$

The i -th node is connected to the $(i-1)$ -th one by an hypermultiplet (A_i, \tilde{A}_i) while φ_j denotes the adjoint chiral multiplet of the j -th node. The superpotential reads:

$$W = \sum_{i=1}^3 (\tilde{A}_i \varphi_i A_i - A_i \varphi_{i+1} \tilde{A}_i) + \frac{1}{2} \sum_{i=1}^4 k_i \varphi_i^2. \quad (4.34)$$

Due to $\mathcal{N} = 3$ supersymmetry of the theory, we are allowed to collect at the same time both F-terms and D-terms, in such a way we really need to solve a unique set of equations. Let us define the two vectors $\boldsymbol{\theta}_i = (\varphi_i, \sigma_i)$, $\boldsymbol{\mu}_i = (A_i \tilde{A}_i, |A_i|^2 - |\tilde{A}_i|^2)$: the whole set of F-terms and D-terms now read

$$A_i(\boldsymbol{\theta}_{i+1} - \boldsymbol{\theta}_i) = 0, \quad \tilde{A}_i(\boldsymbol{\theta}_{i+1} - \boldsymbol{\theta}_i) = 0 \quad i = 1, \dots, 3 \quad (4.35)$$

$$\begin{aligned} k_1 \boldsymbol{\theta}_1 &= \boldsymbol{\mu}_1, \\ k_2 \boldsymbol{\theta}_2 &= \boldsymbol{\mu}_2 - \boldsymbol{\mu}_1, \\ k_3 \boldsymbol{\theta}_3 &= \boldsymbol{\mu}_3 - \boldsymbol{\mu}_2, \\ k_4 \boldsymbol{\theta}_4 &= -\boldsymbol{\mu}_3. \end{aligned} \quad (4.36)$$

We can turn on a magnetic charge for each $U(1)$ gauge symmetry and we will denote them with m_i . Monopole operators are labeled by a choice of fluxes, $V_{(m_1, \dots, m_4)}$ and their R-charge and gauge charges can be computed using (2.19)-(2.20) :

$$R[V_{(m_1, \dots, m_4)}] = \frac{1}{2} \sum_{i=1}^3 |m_{i+1} - m_i|, \quad q_i[V_{(m_1, \dots, m_4)}] = -k_i m_i, \quad (4.37)$$

where q_i is the gauge charge with respect to the i -th $U(1)$ gauge group. Let us explain the general strategy in order to solve equations (4.35)-(4.36). Equation (4.35) suggests that it is convenient to study the solutions the vacuum equations according to the vanishing of the VEVs of the bi-fundamental hypermultiplets. Let us assume the VEV of $\boldsymbol{\mu}_1$, or equivalently of the VEV of (A_1, \tilde{A}_1) , to be non vanishing. F-terms imply that in such a case $\boldsymbol{\theta}_1 = \boldsymbol{\theta}_2$, *i.e.* the scalars sitting in

the first two vector multiplets must be set equal. This new condition as a direct consequence on the first two equation in (4.36):

$$\begin{aligned} k_1 \boldsymbol{\theta}_1 &= \boldsymbol{\mu}_1, \\ k_2 \boldsymbol{\theta}_1 &= \boldsymbol{\mu}_2 - \boldsymbol{\mu}_1; \end{aligned} \tag{4.38}$$

summing the two equations, we get $(k_1 + k_2)\boldsymbol{\theta}_1 = \boldsymbol{\mu}_2$. However, with our choice of levels $k_1 + k_2 = -1 + 1 = 0$, so that we need to impose that $\boldsymbol{\mu}_2 = 0$! If we set the second hypermultiplet (A_2, \tilde{A}_2) to zero, the system (4.35)-(4.36) splits into two sub-systems: one involving $\boldsymbol{\mu}_1$ and $\boldsymbol{\theta}_1 = \boldsymbol{\theta}_2$ and another involving $\boldsymbol{\mu}_2$ and $\boldsymbol{\theta}_3, \boldsymbol{\theta}_4$ only. This two sub-systems correspond to F and D terms of two sub-quivers formed by the first two nodes and last two nodes respectively; each sub-quiver is made of two $U(1)$ nodes with opposite CS level and can be thus identified as the half-ABJM theory⁴ [42]. We will refer to this situation as a cut: the vacuum equations set to zero a hypermultiplet, fractionating the initial quiver in sub-quivers. The presence of a cut is not incidental but follows a precise pattern. Observe that in the case under investigation, the cut emerged as consequence of the condition $k_1 + k_2 = 0$. More in general, every time a given quiver contains a connected sub-quiver with vanishing total CS level, $\sum_i k_i = 0$, a cut occurs. The cut is performed in such a way to “isolate” the sub-quiver from the rest of the nodes. For instance, in the model (4.32), there are two possible cuts:

$$\begin{aligned} \text{I :} & \quad \begin{array}{c} A_2 = \tilde{A}_2 = 0 \\ \text{---} \circlearrowleft 1_{-1} \text{---} \circlearrowleft 1_{+1} \text{---} \text{---} \circlearrowleft 1_{-1} \text{---} \circlearrowleft 1_{+1} \text{---} \end{array} \\ \text{II :} & \quad \begin{array}{c} A_1 = \tilde{A}_1 = 0 \qquad A_3 = \tilde{A}_3 = 0 \\ \text{---} \circlearrowleft 1_{-1} \text{---} \text{---} \circlearrowleft 1_{+1} \text{---} \text{---} \circlearrowleft 1_{-1} \text{---} \text{---} \circlearrowleft 1_{+1} \text{---} \end{array} \end{aligned} \tag{4.39}$$

Cut I is the same we observed in our previous analysis while cut II is a new case corresponding to the case $\boldsymbol{\mu}_1 = \boldsymbol{\mu}_3$ in (4.35). Once all the cuts are taken into account, the F and D terms can be univocally solved. We can thus continue the analysis of the moduli space of (4.32) but we need to consider two different branches, corresponding to the two different patterns of cuts.

Branch I. The cut implies $\boldsymbol{\mu}_2 = 0$. The moduli space is actually a product of moduli space, each associated to one sub-quiver. The remaining vacuum equations implies:

$$\boldsymbol{\theta}_1 = \boldsymbol{\theta}_2 = \boldsymbol{\mu}_1, \quad \boldsymbol{\theta}_3 = \boldsymbol{\theta}_4 = \boldsymbol{\mu}_3. \tag{4.40}$$

When scalars sitting in some vector multiplets are set equal, this means that their behavior in a monopole background must be the same and thus also the associated magnetic charge must be set equal. A monopole is parametrized by the following choice of magnetic fluxes (m_L, m_L, m_R, m_R) where $m_1 = m_2 = m_L$ and $m_3 = m_4 = m_R$; L and R stand for left and right respectively. The branch

⁴We define the **half-ABJM theory** by a theory with $U(1)_k \times U(1)_{-k}$ gauge symmetry with a single bi-fundamental hypermultiplet.

is thus parametrized by the expectation values of mesons $A_1\tilde{A}_1$ and $A_3\tilde{A}_3$,⁵ together with the monopoles $V_{(m_L, m_R)}$ with charges:

$$\begin{aligned} R[V_{(m_L, m_R)}] &= \frac{1}{2}|m_L - m_R|, \\ q_1[V_{(m_L, m_R)}] &= -q_2[V_{(m_L, m_R)}] = -m_L, \\ q_3[V_{(m_L, m_R)}] &= -q_4[V_{(m_L, m_R)}] = -m_L. \end{aligned} \quad (4.41)$$

The monopoles are not gauge invariant and they can enter the chiral ring only if they can be dressed using matter fields. Assuming $m_L > 0$ and $m_R > 0$, gauge invariant dressed monopoles are:

$$\bar{V}_{(m_L, m_R)} = V_{(m_L, m_R)} A_1^{m_L} A_3^{m_R}. \quad (4.42)$$

If $m_L < 0$ ($m_R < 0$) the dressing must be performed with \tilde{A}_1 (\tilde{A}_3) instead of A_1 (A_3). R-charge of dressed operators take into account the contribution of matter:

$$R[\bar{V}_{(m_L, m_R)}] = \frac{1}{2}(|m_L - m_R| + |m_L| + |m_R|). \quad (4.43)$$

The dressed monopoles with lowest R-charge are $\bar{V}_{(\pm, 0)}$ and $\bar{V}_{(0, \pm)}$, whose combinations are supposed to span all the charge lattice. Even if we know the possible generators of chiral rings, we do not which quantum relations can emerge at low energy. The puzzle can be solved computing the Hilbert series associated to such configurations of fields. In fact, it is common lore that Hilbert series contain the full quantum information once dynamics of (dressed) monopoles is taken into account. Let us briefly review how Hilbert series can be computed in this case, using the same procedure as presented in [42]. The first step is to compute the so called baryonic generating function of each half-ABJM sector. A baryonic generating function [62–64] is a Hilbert series counting gauge-invariant operators together with operators with non-trivial gauge charge that can be used in order to dress monopoles. It can be constructed with a procedure analogous to the one explained in section 4.1: each hypermultiplet transforming in the representation \mathcal{R} enters through $PE[t\chi(\mathbf{z}, \mathbf{x})]$ where \mathbf{z} is a vector of gauge fugacities and \mathbf{x} is a vector of flavor fugacities; adjoint chiral multiplets enter as a constraints, $PE[-t^2\chi_{\text{adj}}(\mathbf{z})]$. Gauging is implemented integrating over the gauge fugacities. If we want to count operators with charge B under some Abelian gauge symmetry with fugacity z , it is enough to add to the baryonic generating function integrand a contribution z^{-B} . In the half-ABJM case, we know that gauge invariant operators that can dress monopoles must have charge B with respect to one node and charge $-B$ with respect to the other one. The generating function admits an analytic form:

$$g_{\text{ABJM}/2}(t; B) = \oint_{|u_1|=1} \frac{dz_1}{2\pi i z_1} \oint_{|z_2|=1} \frac{dz_2}{2\pi i z_2} u_1^{-B} z_2^B \text{PE}[(z_1 u_2^{-1} + z_1^{-1} z_2) t] = \frac{t^{|B|}}{1 - t^2}. \quad (4.44)$$

In order to correctly dress the monopoles, we will set $B = m_L$ or $B = m_R$. The baryonic generating function needs to be combine it with bare monopole contribution. Monopoles enter through the multiplicative factor $t^{2R[\mathbf{m}]} \prod_{i=1} x_i^{m_i}$ where t is the R-symmetry fugacity, $R[\mathbf{m}]$ is the bare monopole R-symmetry

⁵Or equivalently φ_1 and φ_3 using F-terms.

depending on the vector of fluxes $\mathbf{m} = (m_1, \dots, m_n)$ while x_i is the fugacity for the i -th topological symmetry. Finally, we need to sum over all possible magnetic fluxes. At the end of the day, we are able to compute the Hilbert series of (4.32) with cut I:

$$\begin{aligned} H_{(4.32)}^{(I)}(t; x_1, x_2) &= \sum_{m_L \in \mathbb{Z}} \sum_{m_R \in \mathbb{Z}} t^{|m_L - m_R|} g_{\text{ABJM}/2}(t; m_L) g_{\text{ABJM}/2}(t; m_R) = \\ &= \sum_{m_L \in \mathbb{Z}} \sum_{m_R \in \mathbb{Z}} t^{|m_L - m_R|} \frac{t^{|m_L|}}{1 - t^2} \frac{t^{|m_R|}}{1 - t^2} x_1^{m_L} x_2^{m_R} = \sum_{m=0}^{\infty} \chi_{[m, m]}^{SU(3)}(x_1, x_2) t^{2m}. \end{aligned} \quad (4.45)$$

As we have discussed in section 2.3, this is the Hilbert series for the moduli space of one $SU(3)$ instanton on \mathbb{C}^2 , or equivalently the minimal nilpotent orbit of $SU(3)$. This admits a description in terms of 3×3 complex matrices M such that $\text{tr} M = M^2 = 0$. With a bit of guesswork, one can show that this matrix M can be written in terms of the following eight generators of the chiral ring:

$$M = \begin{pmatrix} \varphi_L & V_{(1,0)} & V_{(1,1)} \\ V_{(-1,0)} & \varphi_R & V_{(0,1)} \\ V_{(-1,-1)} & V_{(0,-1)} & -\varphi_L - \varphi_R \end{pmatrix} \quad (4.46)$$

where $\varphi_L = \varphi_1 = \varphi_2$ and $\varphi_R = \varphi_3 = \varphi_4$.

Branch I. The second possible cut in (4.39) sets $\mu_1 = \mu_3 = 0$. Moreover, vacuum equations also implies that $\theta_1 = \theta_4 = 0$. This means that the two external nodes are completely frozen and do not participate to the moduli space. We can study the effective sub-quiver formed by the two internal nodes in (4.32).⁶ The F and D terms now implies that:

$$A_2(\theta_2 - \theta_3) = \tilde{A}_2(\theta_2 - \theta_3) = 0, \quad \theta_2 - \mu_2 = -\theta_3 - \mu_2 = 0. \quad (4.47)$$

A unique non-trivial solution is admitted: $\theta_2 = \theta_3 = \mu_2$. This also implies that the unique non-vanishing magnetic charges are $m_2 = m_3 \equiv m$. As before, we prefer to trade the vector multiplet scalars for monopoles, that are right degrees of freedom in the IR. In the case at hand, monopoles are labeled by the unique magnetic charge m and have charges:

$$\begin{aligned} R[V_m] &= \frac{1}{2} \sum_{i=1}^3 |m_i - m_{i+1}| = (|0 - m| + |m - m| + |m - 0|) = |m|, \\ q_1[V_m] &= q_4[V_m] = 0, \quad q_2[V_m] = -q_3[V_m] = -m. \end{aligned} \quad (4.48)$$

Monopoles are not gauge invariant and need to be dressed:

$$\bar{V}_{m>0} = V_m(\tilde{A}_2)^m, \quad \bar{V}_{m<0} = V_m(A_2)^m, \quad (4.49)$$

with R-charge $R[\bar{V}_m] = \frac{|m|}{2}$. We can compute the Hilbert series associated to this branch. We first need to compute the baryonic generating function counting the operators with charges $q_2 = -q_3 = B$ made out the hypermultiplet

⁶This is not entirely true: the presence of the two external nodes leaves a footprint in the R-charge of the monopoles

(A_2, \tilde{A}_2) . It turns out that such generating function is $g_{\text{ABJM}/2}(t; m)$ defined before. taking into account the dressing by the monopole operators, we get:

$$\begin{aligned} H_{(4.32)}^{(\text{II})}(t; z) &= \sum_{m \in \mathbb{Z}} t^{2|m|} g_{\text{ABJM}/2}(t; m) z^m \\ &= \sum_{m \in \mathbb{Z}} t^{2|m|} \frac{t^m}{1-t^2} = \text{PE} [t^2 + (z + z^{-1})t^3 - t^6] . \end{aligned} \quad (4.50)$$

This indicates that this branch is isomorphic to $\mathbb{C}^2/\mathbb{Z}_3$. The generators of this moduli space are V_+ , V_- and $\varphi_2 = \varphi_3 \equiv \varphi$, satisfying the relation

$$V_+ V_- = \varphi^3 . \quad (4.51)$$

Branches I and II of (4.32) are the Higgs and Coulomb branches of 3d $\mathcal{N} = 4$ $U(1)$ gauge theory with 3 flavors, as pointed out in [65]. The brane system of the former can be obtained by applying the $SL(2, \mathbb{Z})$ action T^T to the brane system of the latter.

4.2.2 General Abelian linear quivers

With the lessons learned from the previous example, we are ready to study Abelian linear quivers with arbitrary CS levels in full generality.

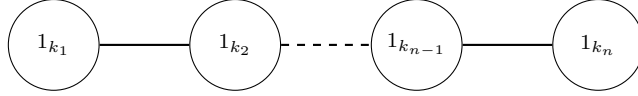

$$(4.52)$$

This is made up of n $U(1)$ gauge nodes with Chern-Simons levels k_i , $i = 1, \dots, n$. The i -th node is connected to the $(i-1)$ -th one by a hyper-multiplet (A_i, \tilde{A}_i) . In $\mathcal{N} = 2$ language, the quiver appears as:

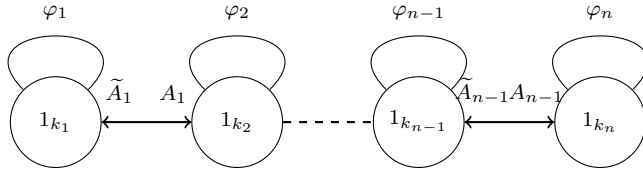

$$(4.53)$$

with the superpotential

$$W = \sum_{i=1}^{n-1} (\tilde{A}_i \varphi_i A_i - A_i \varphi_{i+1} \tilde{A}_i) + \frac{1}{2} \sum_{i=1}^n k_i \varphi_i^2 . \quad (4.54)$$

We introduce again the vectors $\boldsymbol{\theta}_i = (\varphi_i, \sigma_i)$ and $\boldsymbol{\mu}_i = (A_i \tilde{A}_i, |A_i|^2 - |\tilde{A}_i|^2)$ that allows to write F and D terms in a compact way:

$$A_i (\Phi_{i+1} - \Phi_i) = 0, \quad \tilde{A}_i (\Phi_{i+1} - \Phi_i) = 0 \quad i = 1, \dots, n-1 \quad (4.55)$$

$$\begin{aligned}
k_1 \boldsymbol{\theta}_1 &= \boldsymbol{\mu}_1 \\
k_i \boldsymbol{\theta}_i &= \boldsymbol{\mu}_i - \boldsymbol{\mu}_{i-1} \quad i = 2, \dots, n-1 \\
k_n \boldsymbol{\theta}_n &= -\boldsymbol{\mu}_{n-1}
\end{aligned} \tag{4.56}$$

Moreover, the R-charge and gauge charges of the monopole operators with flux (m_1, \dots, m_n) read, respectively:

$$R[V_{(m_1, \dots, m_n)}] = \frac{1}{2} \sum_{i=1}^{n-1} |m_{i+1} - m_i|, \quad q_i[V_{(m_1, \dots, m_n)}] = -k_i m_i \tag{4.57}$$

where m_i is the magnetic flux of the i -th gauge group. The general technique in order to solve the vacuum equation is quite similar to the one before. The various branches can be studied according to the vanishing of the VEVs of the bi-fundamental hypermultiplets. Every time a sub-quiver with vanishing total CS level is present, a cut occurs; this means that we need to set to zero the ‘‘boundary’’ hypermultiplets and divide the sub-quiver from the remaining node. In (4.58) we illustrate a typical situation with two cuts; we will refer to this setup to make discussion lighter, but generalization to an arbitrary number of cuts is straightforward.

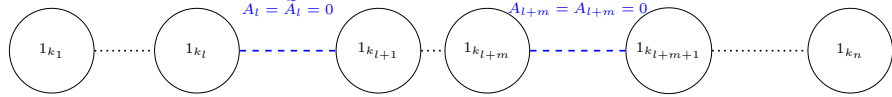

(4.58)

The initial quiver, made of n nodes, contains a sub-quiver of m nodes such that $\sum_{i=1}^m k_{l+i} = 0$. The two extremal nodes are labeled by $l+1$ and $l+m$ respectively. Following the previous discussion, we need to perform a cut, $\boldsymbol{\mu}_l = \boldsymbol{\mu}_{l+m} = 0$, dividing the initial quiver into three sub-quiver, that we will refer to as ‘‘left’’, ‘‘central’’ and ‘‘right’’. The vacuum equations split into three systems of equation, one for each sub-quiver.

Let us consider the left sub-quiver and assume that $\boldsymbol{\mu}_i$ are non-vanishing for all $i = 1, 2, \dots, l$. Then (4.55) implies that $\boldsymbol{\theta}_i = \boldsymbol{\theta}_L = (\varphi_L, \sigma_L) \forall i = 1, 2, \dots, l$. The sum of the first l equations in (4.56) provides the following additional constraint:

$$\left(\sum_{i=1}^l k_i \right) \boldsymbol{\theta} = \boldsymbol{\mu}_l = 0. \tag{4.59}$$

Since $\boldsymbol{\mu} \neq 0$ (otherwise $\boldsymbol{\mu}_i$ would be zero, contradicting our assumption), we see that a *necessary condition* for the left sub-quiver to contribute non-trivially to the moduli space of vacua is

$$\sum_{i=1}^l k_i = 0. \tag{4.60}$$

A similar argument also applies for the right sub-quiver. We assume that $\boldsymbol{\mu}_i$ are non-vanishing for all $i = l+m+1, \dots, n$. A necessary condition for this sub-quiver to contribute non-trivially to the moduli space is

$$\sum_{i=l+m+1}^n k_i = 0, \tag{4.61}$$

Moreover, $\theta_i = \theta_R = (\varphi_R, \sigma_R) \forall i = l + m, \dots, n$. Finally, the central quiver participates non-trivially to the moduli space by construction. Since all the θ in each sub-quiver are set equal, also the magnetic fluxes for the monopole operators for all nodes in each sub-quiver are equal:

$$\begin{aligned} m_1 &= m_2 = \dots = m_l \equiv m_L, \\ m_{l+1} &= m_{l+2} = \dots = m_{l+m} \equiv m_C, \\ m_{l+m+1} &= m_{l+m+2} = \dots = m_n \equiv m_R. \end{aligned} \quad (4.62)$$

and monopoles are thus parametrize by a triple of fluxes (m_L, m_C, m_R) only; their R-charge reads:

$$R[V_{(m_1, \dots, m_n)}] = \frac{1}{2} \sum_{i=1}^{n-1} |m_i - m_{i+1}| = \frac{1}{2} (|m_L - m_C| + |m_C - m_R|). \quad (4.63)$$

The Hilbert series can be computed in the same way we explained in section 4.2.1. The idea is to count the monopole operators dressed by appropriate chiral fields in the theory such that the combination is gauge invariant. The appropriate combination of chiral fields that are used to dress the monopole operators are counted by the baryonic generating function [63].

Let $g_L(t, \mathbf{B})$, $g_C(t, \mathbf{B})$ and $g_R(t, \mathbf{B})$ be baryonic generating functions for the left, central and right sub-quivers, respectively. Then, the Hilbert series for the moduli space for quiver (4.58) is given by

$$\begin{aligned} H(t; z_L, z_C, z_R) &= \sum_{m_L \in \mathbb{Z}} \sum_{m_C \in \mathbb{Z}} \sum_{m_R \in \mathbb{Z}} t^{|m_L - m_C| + |m_C - m_R|} z_L^{m_L} z_C^{m_C} z_R^{m_R} \times \\ &\quad g_L(t, \{k_1 m_L, \dots, k_l m_L\}) g_C(t, \{k_{l+1} m_C, \dots, k_{m-1} m_C\}) \times \\ &\quad g_R(t, \{k_m m_R, \dots, k_n m_R\}), \end{aligned} \quad (4.64)$$

where $z_{L,C,R}$ are fugacities for the topological symmetries. The first line is the contribution from the monopole operators and the second and third lines are the contribution from an appropriate combination of chiral fields in the quiver that will be used to dress the monopole operators. In general, this sum is hard to evaluate. However, there is a special class whose moduli space is explicitly known: the class of linear Abelian quivers with no cut at all.

4.2.3 Example: No cut in the quiver (4.52)

We assume that μ_i are non-vanishing for all $i = 1, \dots, n$, *i.e.* there is no cut in the quiver. In this case, (4.55) implies that

$$\theta = \theta = (\varphi, \sigma) \quad \forall i = 1, \dots, n \quad (4.65)$$

We know that this quiver admits a non-trivial moduli space if and only if:

$$(k_1 + k_2 + \dots + k_n) \theta = 0 \quad (4.66)$$

Note that $\theta = 0$ would imply $\mu_i = 1 \forall i$ contradicting the initial assumption that all $\mu_i \neq 0$. Thus, as we discuss before, the moduli space is non-trivial if⁷

$$\sum_{i=1}^n k_i = 0 \quad (4.67)$$

The bare monopoles $V_m = V_{(m, \dots, m)}$, with flux (m, \dots, m) , have R -charge $R[V_{(m, \dots, m)}] = 0$. They need to be dressed in order to make them gauge invariant, because of their gauge charge under the i -th gauge group is $q_i[V_{(m, \dots, m)}] = -k_i m$. Let us define for convenience

$$K_i = \sum_{j=1}^i k_j \quad (4.68)$$

If $K_i \geq 0$ for all $i = 1, \dots, n-1$, we can form the following gauge invariant dressed monopole operator:

$$\begin{aligned} \bar{V}_+ &\equiv V_{(1, \dots, 1)} A_1^{K_1} A_2^{K_2} \dots A_{n-1}^{K_{n-1}} , \\ \bar{V}_- &\equiv V_{(-1, \dots, -1)} \tilde{A}_1^{K_1} \tilde{A}_2^{K_2} \dots \tilde{A}_{n-1}^{K_{n-1}} . \end{aligned} \quad (4.69)$$

Note that if $K_j < 0$ for some j , we replace $A_j^{K_j}$ in the first equation by $\tilde{A}_j^{-K_j}$, and $\tilde{A}_j^{K_j}$ in the second equation by $A_j^{-K_j}$. In any case, the R -charges of the above dressed monopole operators are

$$R[\bar{V}_\pm] = \frac{1}{2} \sum_{i=1}^{n-1} |K_i| = \frac{1}{2} K \quad (4.70)$$

with

$$K \equiv \sum_{i=1}^{n-1} |K_i| . \quad (4.71)$$

The chiral ring is generated by the three operators $\{\varphi, \bar{V}_+, \bar{V}_-\}$, satisfying the following relation:

$$\bar{V}_+ \bar{V}_- = \varphi^K . \quad (4.72)$$

Thus, the variety associated to this branch is:

$$\mathbb{C}^2 / \mathbb{Z}_K . \quad (4.73)$$

We can obtain the same result using the Hilbert series. Let us call $\{q_1, q_2, \dots, q_n\}$ the fugacities associated to the n gauge nodes and t the fugacity associated to the R -symmetry. The ingredients entering the Hilbert series are:

- The $n-1$ bi-fundamental hypermultiplets contribute as:

$$\text{PE}[t(q_1 q_2^{-1} + q_1^{-1} q_2)] \text{PE}[t(q_2 q_3^{-1} + q_2^{-1} q_3)] \dots \text{PE}[t(q_{n-1} q_n^{-1} + q_{n-1}^{-1} q_n)] \quad (4.74)$$

⁷For circular quiver, the constraint (4.67) is a necessary condition for the theory to be holographically dual to some background in Type-IIA supergravity with vanishing Romans mass [66].

- There is also a contribution from φ which gives $\text{PE}[t^2]$.
- The F -terms (4.56) impose further $(n-1)$ constraints on the former, after taking into account the condition (4.66), which is the overall sum of (4.56). These contribute $\text{PE}[-(n-1)t^2]$ to the Hilbert series.

The baryonic generating function is thus:

$$g(t; \mathbf{B}) = \text{PE}[-(n-1)t^2] \text{PE}[t^2] \oint \frac{dq_1}{2\pi i q_1^{1+B_1}} \cdots \oint \frac{dq_n}{2\pi i q_n^{1+B_n}} \prod_{i=1}^{n-1} \text{PE}[t(q_i q_{i+1}^{-1} + q_i^{-1} q_{i+1})] \quad (4.75)$$

and can perform a change of variable:

$$\{y_1, y_2, \dots, y_n\} = \{q_1 q_2^{-1}, q_2 q_3^{-1}, \dots, q_{n-1} q_n^{-1}, q_n\} \quad (4.76)$$

Thus, the baryonic function becomes:

$$\text{PE}[-(n-2)t^2] \prod_{i=1}^{n-1} \oint \frac{dy_i}{2\pi i y_i^{1+\tilde{B}_i}} \text{PE}[t(y_i + y_i^{-1})] \oint \frac{dy_n}{2\pi i y_n^{1+\tilde{B}_n}} \quad (4.77)$$

where we defined $\tilde{B}_i = \sum_{j=1}^i B_j$. The previous integrals are known:

$$\oint \frac{dy_i}{2\pi i y_i^{1+\tilde{B}_i}} \text{PE}[t(y_i + y_i^{-1})] = \frac{t^{|\tilde{B}_i|}}{1-t^2}, \quad \oint \frac{dy_n}{2\pi i y_n^{1+\tilde{B}_n}} = \delta_{\tilde{B}_n, 0} \quad (4.78)$$

and then the baryonic generating function simplifies to

$$g(t; \mathbf{B}) = \frac{t^{\sum_{i=1}^{n-1} |\tilde{B}_i|}}{1-t^2} \delta_{\tilde{B}_n, 0}, \quad \text{with } \tilde{B}_i = \sum_{j=1}^i B_j. \quad (4.79)$$

Recall that the charge of the monopole operator under the $U(1)_i$ gauge symmetry is $q_i[V_{(m, \dots, m)}] = -k_i m$. As a consequence, the Hilbert series reads:

$$\begin{aligned} H(t; z) &= \sum_{m \in \mathbb{Z}} g(t; \{k_1 m, \dots, k_n m\}) z^m \\ &= \frac{1}{1-t^2} \sum_{m \in \mathbb{Z}} t^{|m| \sum_{i=1}^n |\tilde{B}_i|} z^m \\ &= \frac{1}{1-t^2} \sum_{m \in \mathbb{Z}} t^{K|m|} z^m \\ &= \text{PE} [t^2 + (z + z^{-1})t^K - t^{2K}], \end{aligned} \quad (4.80)$$

where \tilde{B}_n in (4.79) is $m \sum_{i=1}^n k_i = 0$ and hence the Kronecker delta gives 1. Here z is the fugacity for the topological symmetry. We obtained exactly the Hilbert series of $\mathbb{C}^2/\mathbb{Z}_K$.

4.3 Theories with one J -fold

In this section we want to present the analysis of moduli space of a class of theories dual to a brane configurations with one J -fold and a collection of $(1, k)$

branes. The associated quiver is

$$(4.81)$$

In the 3d $\mathcal{N} = 2$ notation, this can be rewritten as

$$(4.82)$$

with the superpotential

$$W = \sum_{i=1}^{n-1} (-\tilde{A}_i \varphi_i A_i + A_i \varphi_{i+1} \tilde{A}_i) + \left(\sum_{j=1}^n \frac{1}{2} k_j \varphi_j^2 \right) - \varphi_1 \varphi_n . \quad (4.83)$$

where we emphasize the contribution from the mixed CS term due to the $T[U(1)]$ theory in blue. In fact, as we observed in section (3.1), $T[U(1)]$ is nothing but a mixed Chern-Simons coupling between the two linked nodes. Using the same notation introduced in section 4.2, the vacuum equations can be written in the following compact way:

$$A_i(\theta_{i+1} - \theta_i) = 0, \quad \tilde{A}_i(\theta_{i+1} - \theta_i) = 0 \quad i = 1, \dots, n-1 \quad (4.84)$$

$$\begin{aligned} k_1 \theta_1 - \theta_n &= \mu_1 \\ k_i \theta_i &= \mu_i - \mu_{i-1} \quad i = 2, \dots, n-1 \\ k_n \theta_n - \theta_1 &= -\mu_{n-1} \end{aligned} \quad (4.85)$$

Again, we emphasized in blue the deformation of the vacuum equations due to the $T[U(1)]$ theory in blue. The charges of the monopole operators $V_{(m_1, \dots, m_n)}$ under the i -th $U(1)$ gauge group are

$$\begin{aligned} q_1[V_{(m_1, \dots, m_n)}] &= -(k_1 m_1 - m_n) \\ q_i[V_{(m_1, \dots, m_n)}] &= -k_i m_i, \quad i = 2, \dots, n-1 \\ q_n[V_{(m_1, \dots, m_n)}] &= -(k_n m_n - m_1) . \end{aligned} \quad (4.86)$$

The R -charges of $V_{(m_1, \dots, m_n)}$ is given by

$$R[V_{(m_1, \dots, m_n)}] = \frac{1}{2} \sum_{i=1}^{n-1} |m_i - m_{i+1}| . \quad (4.87)$$

In section 4.2 we observed that branches of solutions to this kind of vacuum equations are strictly related to the expectation value of bi-fundamental hypermultiplets. In particular, the existence of sub-quiver with a particular value of total CS level can induce a cut, meaning that we are forced to set to zero the VEVs of all the hypermultiplets connecting the sub-quiver to the remaining nodes. Moreover, after all the needed cuts have been performed, each sub-quiver can participate non-trivially on the moduli space only if some constraint on the total CS level is satisfied.

4.3.1 Cuts are needed

In order to understand when a cut needs be performed, we can follow an opposite approach with respect to the analysis in section 4.2: this time we assume that we are forced to perform the cut and we will deduce the constraint on CS level forcing the cut *a posteriori*. Let us assume that only one cut is needed and this sets to zero $\mu_l = 0$. The quiver branches into two sub-quivers still connected by the T-link:

$$(4.88)$$

As we learned, every time a cut occurs, equations (4.84) set all vector multiplet scalars to be equal in each sub-quiver; this condition extends also to magnetic fluxes:

$$\begin{aligned} \theta_1 = \dots = \theta_l = \theta_L = (\varphi_L, \sigma_R), \quad \theta_{l+1} = \dots = \theta_n = \theta_R = (\varphi_R, \sigma_R) \\ m_1 = \dots = m_l = m_L, \quad m_{l+1} = \dots = m_n = m_R. \end{aligned} \quad (4.89)$$

Moreover, F-terms (4.85) split into two sub-systems:

$$\begin{aligned} k_1 \theta - \tilde{\theta} = \mu_1, \quad k_2 \theta = \mu_2 - \mu_1, \quad \dots, \quad k_l \theta = -\mu_{l-1} \\ k_{l+1} \tilde{\theta} = \mu_{l+1}, \quad k_{l+2} \tilde{\theta} = \mu_{l+2} - \mu_{l+1}, \quad \dots, \quad k_n \tilde{\theta} - \theta = -\mu_n \end{aligned} \quad (4.90)$$

Constraints on CS levels usually come from the sums over the equations in each subsystem. Also in this case, we get the following consistency equations:

$$\left(\sum_{i=1}^l k_i \right) \theta_L - \theta_R = 0, \quad \left(\sum_{i=l+1}^n k_i \right) \theta_R - \theta_L = 0 \quad (4.91)$$

Since we can not set to zero neither θ_L nor θ_R , we discover that a cut must occur every time the following relation is satisfied by Chern-Simons levels:

$$\left(\sum_{i=1}^l k_i \right) \left(\sum_{i=l+1}^n k_i \right) = 1. \quad (4.92)$$

Since all Chern-Simons levels are integers, the above equation is equivalent to

$$\sum_{i=1}^l k_i = \sum_{i=l+1}^n k_i = \pm 1 \quad (4.93)$$

The system of equations (4.91) is now simply solved by $\theta_R = \pm\theta_L$ (and consequently $m_R = \pm m_L$). Let us analyze separately the two cases:

- $\Phi = \tilde{\Phi}$: In this case we choose

$$\sum_{i=1}^l k_i = \sum_{i=l+1}^n k_i = 1. \quad (4.94)$$

This moduli space is parametrized by φ and the two basic dressed monopole operators. Let us define for convenience

$$\tilde{k}_j = (k_1 - 1, k_2, \dots, k_{n-1}, k_n - 1), \quad \tilde{K}_i = \sum_{j=1}^i \tilde{k}_j. \quad (4.95)$$

If $\tilde{K}_i \geq 0$ for all $i = 1, \dots, l-1, l+1, \dots, n-1$, the basic dressed monopole operators are⁸

$$\begin{aligned} \bar{V}_+ &= V_{(1,1,\dots,1)} A_1^{\tilde{K}_1} \dots A_{l-1}^{\tilde{K}_{l-1}} A_{l+1}^{\tilde{K}_{l+1}} \dots A_{n-1}^{\tilde{K}_{n-1}} \\ \bar{V}_- &= V_{-(1,1,\dots,1)} \tilde{A}_1^{\tilde{K}_1} \dots \tilde{A}_{l-1}^{\tilde{K}_{l-1}} \tilde{A}_{l+1}^{\tilde{K}_{l+1}} \dots \tilde{A}_{n-1}^{\tilde{K}_{n-1}}, \end{aligned} \quad (4.96)$$

The R -charge of the above dressed monopole operators are

$$R[\bar{V}_\pm] = \frac{1}{2} \sum_{\substack{1 \leq i \leq n-1 \\ i \neq l}} |\tilde{K}_i| \equiv \frac{1}{2} \tilde{K} \quad (4.97)$$

where the bare monopole operators have R -charge $R[V_{\pm(1,1,\dots,1)}] = 0$, and we define

$$\tilde{K} = \sum_{\substack{1 \leq i \leq n-1 \\ i \neq l}} |\tilde{K}_i|. \quad (4.98)$$

Thus, \bar{V}_\pm satisfy

$$\bar{V}_+ \bar{V}_- = \varphi^{\tilde{K}}. \quad (4.99)$$

This branch of the moduli space is therefore

$$\mathbb{C}^2 / \mathbb{Z}_{\tilde{K}}. \quad (4.100)$$

The same result is confirmed from a Hilbert series computation. Let $g_L(t, \mathbf{B})$ and $g_R(t, \mathbf{B})$ be baryonic generating functions for the left sub-quiver (containing nodes $1, \dots, l$) and the right sub-quivers (containing nodes $l+1, \dots, n$), respectively. Then, the Hilbert series for this case is given by

$$\begin{aligned} H(t; z) &= \sum_{m \in \mathbb{Z}} z^m g_L(t, \{(k_1 - 1)m, k_2 m, \dots, k_l m\}) \times \\ &\quad g_R(t, \{k_{l+1} m, \dots, k_{n-1} m, (k - 1)m\}) (1 - t^2), \end{aligned} \quad (4.101)$$

⁸If $\tilde{K}_j < 0$ for some j , we replace $A_j^{\tilde{K}_j}$ in the first equation by $\tilde{A}_j^{-\tilde{K}_j}$, and $\tilde{A}_j^{\tilde{K}_j}$ in the second equation by $A_j^{-\tilde{K}_j}$.

where z is a fugacity for the topological symmetry. Using the expressions for g_L and g_R given by (4.79), we obtain

$$\begin{aligned} H(t; z) &= \sum_{m \in \mathbb{Z}} z^m \frac{t^{|m| \sum_{i=1}^{l-1} |\tilde{K}_i|}}{1-t^2} \delta_{\sum_{i=1}^l k_i, 1} \times \frac{t^{|m| \sum_{i=l+1}^{n-1} |\tilde{K}_i|}}{1-t^2} \delta_{\sum_{i=l+1}^n k_i, 1} (1-t^2) \\ &= \begin{cases} \text{PE} \left[t^2 + (z + z^{-1}) t^{\tilde{K}} - t^{2\tilde{K}} \right] & \text{if } \sum_{i=1}^l k_i = \sum_{i=l+1}^n k_i = 1 \\ 0 & \text{otherwise .} \end{cases} \end{aligned} \quad (4.102)$$

The Hilbert series in the first line in the second equality is indeed that of $\mathbb{C}^2/\mathbb{Z}_{\tilde{K}}$.

- $\Phi = -\tilde{\Phi}$: In this case, we choose

$$\sum_{i=1}^l k_i = \sum_{i=l+1}^n k_i = -1 . \quad (4.103)$$

The basic monopole operators are $V_{+-} \equiv V_{(1^l, (-1)^{n-l})}$ and $V_{-+} \equiv V_{((-1)^l, 1^{n-l})}$, whose R -symmetry are

$$R[V_{+-}] = R[V_{-+}] = 1 . \quad (4.104)$$

Let us define for convenience

$$\begin{aligned} \tilde{k}'_j &= (k_1 + 1, k_2, \dots, k_{n-1}, k_n + 1) , \\ \tilde{K}'_i &= \sum_{j=1}^i \tilde{k}'_j . \end{aligned} \quad (4.105)$$

For $\tilde{K}'_i > 0$ for $i = 1, \dots, l-1$ and $\tilde{K}'_j < 0$ for $j = l+1, \dots, n-1$, the basic dressed monopole operators can be written as

$$\begin{aligned} \bar{V}_{+-} &= V_{+-} A_1^{\tilde{K}'_1} \dots A_{l-1}^{\tilde{K}'_{l-1}} A_{l+1}^{-\tilde{K}'_{l+1}} \dots A_{n-1}^{-\tilde{K}'_{n-1}} \\ \bar{V}_{-+} &= V_{-+} \tilde{A}_1^{\tilde{K}'_1} \dots \tilde{A}_{l-1}^{\tilde{K}'_{l-1}} \tilde{A}_{l+1}^{-\tilde{K}'_{l+1}} \dots \tilde{A}_{n-1}^{-\tilde{K}'_{n-1}} , \end{aligned} \quad (4.106)$$

where it should be noted that in this case $\sum_{i=1}^l k_i = \sum_{i=l+1}^n k_i = -1$. Similarly as before, \bar{V}_{\pm} satisfy

$$\bar{V}_{+-} \bar{V}_{-+} = \varphi^{\tilde{K}' + 2} , \quad (4.107)$$

where we define

$$\tilde{K}' = \sum_{\substack{1 \leq i \leq n-1 \\ i \neq l}} |\tilde{K}'_i| . \quad (4.108)$$

This branch of the moduli space is therefore

$$\mathbb{C}^2/\mathbb{Z}_{\tilde{K}' + 2} . \quad (4.109)$$

This result can be confirmed computing Hilbert series along the very same lines of the $\theta_L = \theta_R$ case. The only difference is the choice of baryonic charges to assign to the baryonic generating functions other than R-charge and topological charge of the monopole.

The previous result is at the base of the generalization to more cuts. Let us consider for simplicity the following configuration with two cuts, generalization to more than two cuts is straightforward:

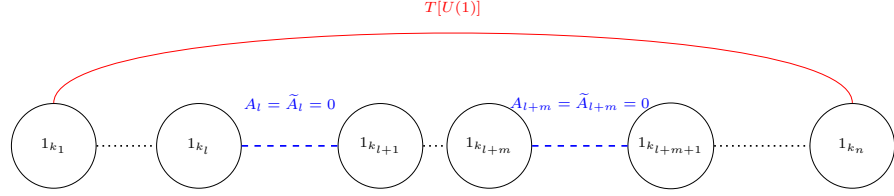

(4.110)

There are three possible reasons why we have been forced to implement the cut:

- The central sub-quiver has vanishing total Chern-Simons level but the two external T-linked sub-quivers do not satisfy (4.92): in this case the moduli space trivially coincides with the one of the central quiver, already investigated in section 4.2.
- The central sub-quiver has non-trivial total CS level and the two external T-linked sub-quivers satisfy (4.92). In this case, the central sub-quiver do not participate at all and the moduli space coincides with the one of the T-linked sub-quiver. Observe, however that this differs from (4.100) or (4.109). In fact, the presence of the central quiver modifies the R-charge of the monopole operator from $\frac{1}{2}|m_L - m_R|$ to $\frac{1}{2}(|m_L - m_C| + |m_C - m_R|) = \frac{1}{2}(|m_L| + |m_R|)$.
- The central sub-quiver has vanishing total CS level and the external T-linked sub-quiver satisfy (4.92):

$$\sum_{i=1}^l k_i = \sum_{i=m+1}^n k_i = \pm 1, \quad \sum_{i=l+1}^m k_i = 0. \quad (4.111)$$

In this case, all the sub-quivers participate non-trivially to the moduli space. There is no unique prescription to describe such moduli space. However, a general formal expression exists for the associated Hilbert series:

$$\begin{aligned} H(t; z_L, z_C, z_R) &= \sum_{m_L \in \mathbb{Z}} \sum_{m_C \in \mathbb{Z}} \sum_{m_R \in \mathbb{Z}} t^{|m_L - m_C| + |m_C - m_R|} z_L^{m_L} z_C^{m_C} z_R^{m_R} \times \\ &\quad g_L(t, \{k_1 m_L - m_R, k_2 m_L, \dots, k_l m_L\}) g_C(t, \{k_{l+1} m_C, \dots, k_{m-1} m_C\}) \times \\ &\quad g_R(t, \{k_m m_R, \dots, k_{n-1} m_R, k_n m_R - m_L\}) (1 - t^2) \delta_{m_R, \pm m_L}, \end{aligned} \quad (4.112)$$

where $\delta_{m_R, \pm m_L}$ takes into account the two possible solutions to (4.111).

This completely exhausts the cases where a cut is needed. However, there is a last case left over: the case when no cuts at all are required.

4.3.2 No cutting at all

In this case μ_i are non-zero for all i . A necessary condition for the non-trivial moduli space is

$$\sum_{i=1}^n k_i = 2. \quad (4.113)$$

This again can be obtained from the sum of the equations in (4.85), with $\theta_i = \theta = (\varphi, \sigma) \neq 0$ (otherwise we would have $\mu_1 = 0$ which contradicts our assumption). The monopole operators $V_{(m_1 \dots m_n)}$ are not gauge invariant; however, the following basic dressed monopole operators are gauge invariant

$$\begin{aligned} \bar{V}_+ &= V_{(1, \dots, 1)} A_1^{\mathcal{K}_1} A_2^{\mathcal{K}_2} \dots A_{n-1}^{\mathcal{K}_{n-1}} \\ \bar{V}_- &= V_{-(1, \dots, 1)} \tilde{A}_1^{\mathcal{K}_1} \tilde{A}_2^{\mathcal{K}_2} \dots \tilde{A}_{n-1}^{\mathcal{K}_{n-1}}, \end{aligned} \quad (4.114)$$

for $\mathcal{K}_i \geq 0$ for all $i = 1, \dots, n-1$, where we define

$$\kappa_i = \{k_1 - 1, k_2, \dots, k_{n-1}, k_n - 1\}, \quad \mathcal{K}_i = \sum_{j=1}^i \kappa_j. \quad (4.115)$$

If $\mathcal{K}_j < 0$ for some j , we replace $A_j^{\mathcal{K}_j}$ by $\tilde{A}_j^{-\mathcal{K}_j}$ in the first equation and $\tilde{A}_j^{\mathcal{K}_j}$ by $A_j^{-\mathcal{K}_j}$ in the second equation.

Since the R -charges of $V_{\pm(1, \dots, 1)}$ are zero, the R -charges of \bar{V}_{\pm} are $\frac{1}{2} \sum_{i=1}^{n-1} |\mathcal{K}_i|$. The moduli space is thus generated by the operators $\{\bar{V}_+, \bar{V}_-, \varphi\}$ subject to the quantum relation

$$\bar{V}_+ \bar{V}_- = \varphi^{\mathcal{K}}, \quad \text{with } \mathcal{K} = \sum_{i=1}^{n-1} |\mathcal{K}_i|; \quad (4.116)$$

this is the algebraic definition of:

$$\mathbb{C}^2 / \mathbb{Z}_{\mathcal{K}}. \quad (4.117)$$

A very simple example of such kind of configuration is the following:

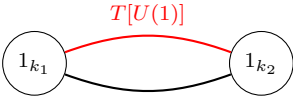

$$(4.118)$$

Whenever $(k_1, k_2) \neq (1, \pm 1)$ or $(k_1, k_2) \neq (-1, \pm 1)$, no cut needs to be introduced. As a result, from (4.113), it is necessary that $k_1 + k_2 = 2$ for this theory to have a non-trivial moduli space. Assuming this, $\kappa_i = \{k_1 - 1, k_2 - 1\}$, $\mathcal{K}_i = \{k_1 - 1, k_1 + k_2 - 2 = 0\}$, and so $\mathcal{K} = |k_1 - 1| = |k_2 - 1|$. Therefore the moduli space of this theory is $\mathbb{C}^2 / \mathbb{Z}_{|k_1 - 1|}$.

4.4 Abelian models with fundamental matter

An interesting generalization of the discussion in section 4.2 and 4.3 consists of models where fundamental matter is added. In this section we want to present

the main features of this generalization. However, in order to make our discussion lighter, we want to study a particular example rather than explore this new possibility in full generality. A detailed study of this class of models can be found in [29]. As usual, we will start studying a model dual to a Hanany-Witten setup without J-folds and then we will consider the T-linked version.

4.4.1 Warp-up: a model without J-folds

Let us consider a model consisting of two Abelian nodes with Chern-Simons levels k_1 and k_2 and connected by a bi-fundamental hypermultiplet (A, \tilde{A}) . We also add f_1 fundamental hypers with charge 1 with respect to the first node and f_2 fundamental hypers with charge 1 with respect to the second node. We will denote the two sets of fundamental hypermultiplets as (Q_i, \tilde{Q}_i) where $i = 1, 2$.

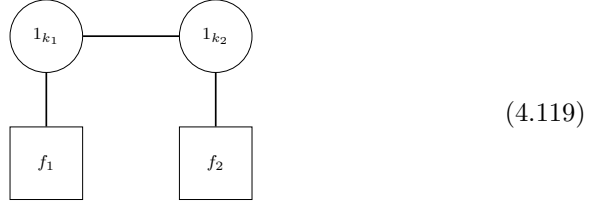

In the $\mathcal{N} = 2$ notation, this quiver can be written as

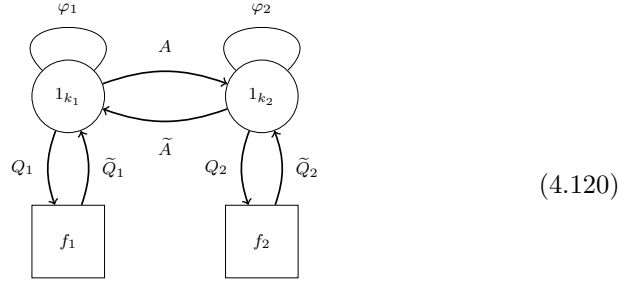

Defining the vectors

$$\boldsymbol{\mu} = (A\tilde{A}, |A|^2 - |\tilde{A}|^2), \quad \boldsymbol{\nu}_j = (Q_j\tilde{Q}_j, |Q_j|^2 - |\tilde{Q}_j|^2), \quad \boldsymbol{\theta} = (\varphi_i, \sigma_i) \quad (4.121)$$

the vacuum equations can be written in the following compact way:

$$A(\boldsymbol{\theta}_i - \boldsymbol{\theta}_{i-1}) = 0, \quad A(\boldsymbol{\theta}_{i+1} - \boldsymbol{\theta}_i) = 0, \quad (4.122)$$

also with $A \leftrightarrow \tilde{A}$,

$$Q_1 \boldsymbol{\theta}_1 = 0, \quad Q_2 \boldsymbol{\theta}_2 = 0 \quad (4.123)$$

also with $Q \leftrightarrow \tilde{Q}$, and

$$\begin{aligned} k_1 \boldsymbol{\theta}_1 &= \boldsymbol{\mu}_1 + \boldsymbol{\nu}_1 \\ k_2 \boldsymbol{\theta}_2 &= \boldsymbol{\mu}_2 - \boldsymbol{\mu}_1 + \boldsymbol{\nu}_2. \end{aligned} \quad (4.124)$$

The R -charge of the monopole operators $V_{\mathbf{m}}$ with flux $\mathbf{m} = (m_1, \dots, m_n)$ is

$$R[V_{\mathbf{m}}] = \frac{1}{2} \left(|m_1 - m_2| + \sum_{i=1}^2 f_i |m_i| \right). \quad (4.125)$$

Observe that (4.124) implies that fundamental matter and vectors scalar multiplets cannot take expectation value at the same time. We thus have different sets of branches depending on which kind of scalars takes VEV: we will refer to the two kind of choices as Higgs-like and Coulomb-like. In this case we have three possibilities:

Higgs-like $\sigma_i = \varphi_i = 0$: First of all, let us observe that such branch is not sensitive to Chern-Simons level, since we turned off all vector multiplet scalars. (4.122) are automatically solved while (4.123) becomes:

$$\boldsymbol{\mu} + \boldsymbol{\nu}_1 = 0, \quad -\boldsymbol{\mu} + \boldsymbol{\nu}_2 = 0. \quad (4.126)$$

The gauge invariant operators parametrizing this branch are the mesons:

$$M_1 = \tilde{Q}_1^I Q_{1,J}, \quad M_2 = \tilde{Q}_2^A Q_{2,B}, \quad (4.127)$$

and the two (complex conjugate) baryons

$$B^I{}_A = \tilde{Q}_1^I A Q_{2,A}, \quad \bar{B}^A{}_I = Q_2^A \tilde{A} Q_{1,I}. \quad (4.128)$$

Observe that the other meson $A\tilde{A}$ is nothing but $-\text{tr} M_1 = \text{tr} M_2$, because of (4.126). Vacuum equations impose other constraints, for instance

$$B\bar{B} = \tilde{Q}_1^I A (Q_{2,B} \tilde{Q}_2^B) \tilde{A} Q_{1,J} = \tilde{Q}_1^{I_1} Q_{2,J} (A\tilde{A})^2 = M_1^3 \quad (4.129)$$

and so on. The associated Hilbert series can be easily computed since no monopoles are present:

$$H_{\text{Higgs}}(t; \mathbf{x}_1, \mathbf{x}_2) = (1 - t^2)^2 \oint \frac{du_1}{2\pi i u_1} \oint \frac{du_2}{2\pi i u_2} \text{PE} [tq_1 q_2^{-1} + tq_1^{-1} q_2] \\ \text{PE} \left[tq_1 \chi_{\text{fund}}^{SU(f_1)} + tq_1^{-1} \chi_{\text{fund}}^{SU(f_1)} \right] \text{PE} \left[tq_2 \chi_{\text{fund}}^{SU(f_2)} + tq_2^{-1} \chi_{\text{fund}}^{SU(f_2)} \right], \quad (4.130)$$

where the pre-factor $(1 - t^2)^2$ takes into account the two constraints (4.126). In general, it is not an easy task to recognize the variety associated to this Hilbert series, however, being an hyperkähler quotient, it must correspond to the Higgs branch of a $T_{\boldsymbol{\rho}}^{\boldsymbol{\sigma}}[SU(N)]$ for some appropriate choice of $N, \boldsymbol{\rho}, \boldsymbol{\sigma}$.

Coulomb-like $Q_i^I = \tilde{Q}_i^I = 0$: This time, vacuum equations (4.122)-(4.123)-(4.124) reduce to:

$$\boldsymbol{\theta}_1 = \boldsymbol{\theta}_2, \quad k_1 \boldsymbol{\theta} = \boldsymbol{\mu}, \quad k_2 \boldsymbol{\mu} = -\boldsymbol{\mu}. \quad (4.131)$$

The branch is non-trivial only if $k_1 = -k_2 \equiv k$, consistently with the results of section 4.2. Let us assume this is the case. Monopole operators are labeled by a unique magnetic flux $m = m_1 = m_2$ and have R-charge:

$$R[V_m] = R[V_{(m,m)}] = \frac{1}{2}|m|F, \quad F \equiv f_1 + f_2. \quad (4.132)$$

Moreover, since monopoles have non-trivial gauge charge, we need to dress them. The appropriate dressed monopoles are $\bar{V}_{m>0} = V_m A^{km}$ and $V_{m<0} = \bar{V}_m \tilde{A}^{km}$

whose R-charge is $R[\bar{V}_m] = \frac{1}{2}|m|(k+F)$. The monopoles and the vector multiplet scalar $\varphi_1 = \varphi_2 \equiv \varphi$ parametrize the branch and are subject to the quantum constraint:

$$\bar{V}_+ \bar{V}_- = \varphi^{k+F} \quad (4.133)$$

Let us observe that this is quite similar to the moduli space of the half-ABJM model without flavors: fundamental matter participates shifting the monopole R-charge and, in this particular case, results in an effective shifting of the Chern-Simons level $k \rightarrow k+F$.

Mixed branch: In this case, we want to impose mixed condition on the two nodes. Without loss of generality, we can think to set to zero the fundamental hypermultiplets of the first node, $Q_1 = \tilde{Q}_1 = 0$, and set to zero the vector multiplet scalars of the second node $\theta_2 = 0$. With this choice, (4.122) force us to set bi-fundamental matter expectation value to zero. Vacuum equations split into two sets, describing independently the two nodes. The moduli space is thus the product of the Coulomb branch of the first node, that we know to be lifted because of the Chern-Simons level, and the Higgs branch of the second node, that we analyzed in details in section 2.3 and consists of the minimal nilpotent orbit of $SU(f_2)$.

4.4.2 A model with one J-fold

Let us now consider the model where the two nodes are also linked by a $T[U(1)]$ theory:

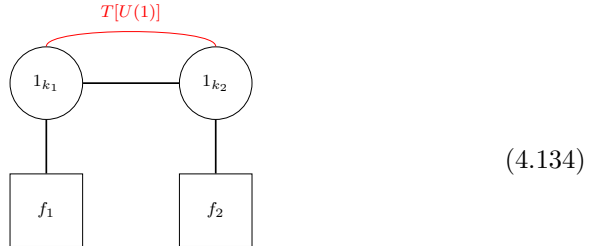

The mixed Chern-Simons term induced by the $T[U(1)]$ coupling modifies the vacuum equations as follows:

$$A(\theta_i - \theta_{i-1}) = 0, \quad A(\theta_{i+1} - \theta_i) = 0, \quad (4.135)$$

$$Q_1 \theta_1 = 0, \quad Q_2 \theta_2 = 0 \quad (4.136)$$

also with $Q \leftrightarrow \tilde{Q}$, $A \leftrightarrow \tilde{A}$, and

$$\begin{aligned} k_1 \theta_1 - \theta_2 &= \mu_1 + \nu_1 \\ k_2 \theta_2 - \theta_1 &= \mu_2 - \mu_1 + \nu_2 . \end{aligned} \quad (4.137)$$

Again, (4.136) implies that we need to choose, for each node, if set to zero the vector multiplet scalars or the fundamental matter expectation value. We have three options: Higgs-like, Coulomb-like and mixed:

Higgs-like $\sigma_i = \varphi_i = 0$: Because all the vector multiplet scalars have vanishing VEV, the presence of the mixed Chern-Simons coupling is irrelevant. The moduli space is the same as the one described in the model without J-folds.

Coulomb-like $Q_i = \tilde{Q}_i = 0$: In this case, the vacuum equations set $\theta_1 = \theta_2 \equiv \theta = (\varphi, \sigma)$ and require that:

$$(k_1 - 1)\theta = (-k_2 + 1)\theta = \mu. \quad (4.138)$$

This set of equations can be solved only if $k_1 + k_2 = 2$, consistently with our discussion in section 4.3. let us assume this is the case and let us define $k_1 - 1 = -k_2 + 1 = \tilde{k}$ and $F = f_1 + f_2$. The Coulomb branch is parametrized by φ and the monopoles. Bare monopoles have the following charges:

$$\begin{aligned} tR[V_m = V_{(m,m)}] &= \frac{1}{2}|m|F, \\ q_1[V_m] &= -(k_1 - 1)m = -\tilde{k}m, \quad q_2[V_m] = -(k_2 + 1)m = \tilde{k}m \end{aligned} \quad (4.139)$$

The Coulomb branch is thus actually parametrized by the dressed monopoles $\bar{V}_{m>0} = V_m A^{\tilde{k}m}$, $\bar{V}_{m<0} = V_m \tilde{A}^{\tilde{k}m}$. Monopoles and φ are constrained by the following quantum relation:

$$\bar{V}_+ \bar{V}_- = \varphi^{\tilde{k}+F}, \quad (4.140)$$

so that we can claim this branch to coincide with $\mathbb{C}^2/\mathbb{Z}_{\tilde{k}+F}$. The only effect of the flavors is to provide an effective shifting of the Chern-Simons level through the contribution to the monopole R-charge.

Mixed branch: This is the most interesting case. We want to set, without loss of generality, $Q_1 = \tilde{Q}_1 = 0$ and $\theta_2 = 0$. Let us recall that in the case without J-folds this has implied the splitting of the moduli space in a product: each factor was associated to one of the node. In the case with a $T[U(1)]$ link this can be no longer true because of the mixed Chern-Simons interaction. In fact, the vacuum equation are solved requiring $A = \tilde{A} = 0$ and:

$$k_1\theta_1 = 0, \quad -\theta_1 = \nu_2. \quad (4.141)$$

This branch is really non-trivial if we require $k_1 = 0$ and we will assume this to be the case. The monopoles have the following charge:

$$\begin{aligned} R[V_m = V_{(m,0)}] &= \frac{1}{2}(|m - 0| + f_2|m|) = \frac{1}{2}|m|(f_2 + 1), \\ q_1[V_m] &= 0, \quad q_2[V_m] = m. \end{aligned} \quad (4.142)$$

Let us stress that because of the mixed CS interaction, the monopole has a non-trivial gauge charge with respect to the first node, but depending on the magnetic fluxes of the first one! In particular, we need a dressing with fundamental matter of the second node:

$$(W_{m>0})^{A_1, \dots, A_m} = V_m \tilde{Q}_2^{A_1} \dots \tilde{Q}_2^{A_m} \dots, \quad (W_{m<0})_{A_1, \dots, A_m} = V_m Q_{2, A_1} \dots Q_{2, A_m}, \quad (4.143)$$

where A_1, \dots, A_m are flavor indices and the monopoles now transform in a non-trivial way under the $SU(f_2)$ global symmetry. The moduli space is highly non trivial. It is parametrized by dressed monopoles $W_+^A, W_{-,A}$ transforming in the (anti-)fundamental representation of $SU(f_2)$ and the mesons $\tilde{Q}_2^A Q_{2,B}$. The Hilbert series can be computed as before: first we need to determine the baryonic generating function of the fundamental matter:

$$g[t, \mathbf{x}; B] = \oint \frac{du}{2\pi i u^{1+B}} PE[t \chi_{\mathbf{fund}}^{SU(f_2)} + t^{-1} \chi_{\overline{\mathbf{fund}}}^{SU(f_2)}]. \quad (4.144)$$

Then, we need to sum over the magnetic fluxes, adding the contribution of bare monopoles, depending on their charges:

$$H_{\text{mix branch}}[t, z, \mathbf{x}] = \sum_m t^{(f_2+1)|m|} z^m g[t, \mathbf{x}; -m]. \quad (4.145)$$

4.5 A case with more J -folds

Up to now, we considered case where only a J -fold has been inserted. However, it is possible to consider also models where more than one J -fold appear at the same time, let us say $\{J_{k_1}, \dots, J_{k_n}\}$. This system of duality walls corresponds to the $SL(2, \mathbb{Z})$ element $J = \prod_{i=1}^n J_{k_i}$, and this can be classified according to the value of $|\text{Tr } J|$. If $|\text{Tr } J| < 2$, then J is said to be elliptic. If $|\text{Tr } J| > 2$, then J is said to be parabolic. If $|\text{Tr } J| = 2$, then J is said to be hyperbolic. The abelian case of $N = 1$, with J hyperbolic, has been extensively studied in [67]. More generally, the authors of [19] studied the holographic dual of such a system⁹ as well as the three sphere partition function in the large N limit and with J hyperbolic, and showed that supersymmetry of the theory is enhanced to $\mathcal{N} = 4$. It should be noted that any parabolic element of $SL(2, \mathbb{Z})$ is conjugate to $\pm T^p$, for some $p \neq 0$.

For definiteness, let us focus on the following model with $U(1)_{k_1} \times U(1)_{k_2}$ gauge group¹⁰:

$$(4.146)$$

For the moment we allow for generic CS levels k_1 and k_2 , but we will see that the vacuum equations admit solutions for non-trivial branches of the moduli space when $J_1 J_2$ is parabolic, *i.e.* $|\text{tr } J_1 J_2| = 2$, or equivalently $k_1 k_2 = 0$ or 4 .

⁹To be precise, the authors considered the case of a single gauge node with more T-link loops and no matter.

¹⁰A more general detailed discussions can be found in [29].

Let us rewrite the quiver (4.146) in $\mathcal{N} = 2$ language:

$$(4.147)$$

with superpotential:

$$W = -\text{tr}(A_1\varphi_1\tilde{A}_1 + A_2\varphi_2\tilde{A}_2) + \frac{1}{2}(k_1\varphi_1^2 + k_2\varphi_2^2) - 2\varphi_1\varphi_2. \quad (4.148)$$

where we denoted in blue the contribution due to the two T -links, consisting of a mixed CS coupling. The vacuum equations are as follows:

$$A_1\varphi_1 = \tilde{A}_1\varphi_1 = 0, \quad A_2\varphi_2 = \tilde{A}_2\varphi_2 = 0, \quad (4.149)$$

and

$$\begin{aligned} k_1\varphi_1 - 2\varphi_2 &= (A_1)_A(\tilde{A}_1)^A, \\ k_2\varphi_2 - 2\varphi_1 &= (A_2)_I(\tilde{A}_2)^I. \end{aligned} \quad (4.150)$$

where $A, B, C = 1, \dots, n_1$ and $I, J, K = 1, \dots, n_2$.

The vacuum equations (4.149) and (4.150) admit the solutions in which $\varphi_1 = \varphi_2 = 0$, regardless of the CS levels. This branch of the moduli space is generated by the mesons $(M_1)_A^B = (A_1)_A(\tilde{A}_1)^B$ and $(M_2)_I^J = (A_2)_I(\tilde{A}_2)^J$ subject to the following relations:

$$\text{rank}(M_{1,2}) \leq 1, \quad M_{1,2}^2 = 0, \quad (4.151)$$

where the first relations come from the fact that each of the matrices M_1 and M_2 is constructed as a product of two vectors, and the second matrix relations follow from (4.150). We refer to this branch of the moduli space as the Higgs branch, denoted by $\mathcal{H}_{(4.146)}$. Indeed, it is isomorphic to a product of the closures of the minimal nilpotent orbits:

$$\mathcal{H}_{(4.146)} = \overline{\mathcal{O}}_{\min}^{SU(n_1)} \times \overline{\mathcal{O}}_{\min}^{SU(n_2)}. \quad (4.152)$$

There are also other non-trivial branches of moduli spaces, which we are analysing in the following.

Let us consider the branch on which $\varphi_1 \neq 0$ and $\varphi_2 \neq 0$. From (4.149), we have $A_1 = \tilde{A}_1 = A_2 = \tilde{A}_2 = 0$. Equations (4.150) admit solutions only if:

$$k_1\varphi_1 = 2\varphi_2, \quad k_2\varphi_2 = 2\varphi_1, \quad k_1k_2 - 4 = 0; \quad (4.153)$$

the latter implies that J_1J_2 has to be parabolic such that either $(k_1, k_2) = (1, 4)$ or $(k_1, k_2) = (2, 2)$. (The case the $(k_1, k_2) = (4, 1)$ can be considered by simply exchanging n_1 and n_2 .) We analyze these cases below.

- **The case of $(k_1, k_2) = (2, 2)$.** The first equation of (4.153) sets $\varphi_1 = \varphi_2 \equiv \varphi$. Since the real scalars in the vector multiplets belong to the same multiplets as $\varphi_{1,2}$, the magnetic fluxes of the monopole operators $V_{(m_1, m_2)}$

satisfy $m_1 = m_2 \equiv m$. The R -charge and the gauge charges with respect to the first and second nodes are respectively

$$\begin{aligned} R[V_{(m,m)}] &= \frac{1}{2}(n_1 + n_2)|m|, \\ q_1[V_{(m,m)}] &= -(k_1 m - 2m) = 0, \quad q_2[V_{(m,m)}] = -(k_2 m - 2m) = 0. \end{aligned} \quad (4.154)$$

Observe that the $V_{(m,m)}$ are gauge neutral for all m . This branch is generated by the basic monopole operators $V_{\pm(1,1)}$ and φ (the latter has R -charge 1), satisfying the quantum relation.

$$V_{(1,1)} V_{-(1,1)} = \varphi^{n_1+n_2}. \quad (4.155)$$

This branch is thus a Coulomb branch and it is isomorphic to

$$\mathcal{C}_{(4.146)}^{k_1=k_2=2} = \mathbb{C}^2 / \mathbb{Z}_{n_1+n_2}. \quad (4.156)$$

In the special case of one flavor, *i.e.* $(n_1, n_2) = (1, 0)$ or $(0, 1)$, we see that the Coulomb branch is isomorphic to $\mathbb{C}^2 \cong \mathbb{H}$. Indeed, the basic monopole operators decouple as a free hypermultiplet.

- **The case of $(k_1, k_2) = (1, 4)$.** In this case $\varphi_1 = 2\varphi_2 = 2\varphi$ and the allowed magnetic fluxes for the monopole operators $V_{(m_1, m_2)}$ are such that $m_1 = 2m_2 \equiv 2m$. The R -charge and the gauge charges with respect to the first and second nodes are respectively

$$\begin{aligned} R[V_{(2m,m)}] &= \frac{1}{2}(n_1|2m| + n_2|m|) = \left(n_1 + \frac{1}{2}n_2\right)|m| \\ q_1[V_{(2m,m)}] &= -[k_1(2m) - 2m] = 0, \quad q_2[V_{(2m,m)}] = -[k_2(m) - 2(2m)] = 0. \end{aligned} \quad (4.157)$$

Observe that $V_{(2m,m)}$ are gauge neutral for all m . This branch of the moduli space is generated by $V_{\pm(2,1)}$ and φ , satisfying the quantum relation:

$$V_{(2,1)} V_{-(2,1)} = \varphi^{2n_1+n_2}. \quad (4.158)$$

This branch is thus a Coulomb branch and it is isomorphic to

$$\mathcal{C}_{(4.146)}^{(k_1, k_2)=(1,4)} = \mathbb{C}^2 / \mathbb{Z}_{2n_1+n_2}. \quad (4.159)$$

It is worth pointing out that for both $(k_1, k_2) = (2, 2)$ and $(1, 4)$, the vacuum equations admit the solutions such that there is a clear separation between the Higgs and Coulomb branches, in the same way as general 3d $\mathcal{N} = 4$ gauge theories. This is mainly due to the fact that the monopole operators are gauge neutral. Note also that both branches are hyperkähler cones.

Next, we analyze the case in which one of φ_1 and φ_2 is zero. For definiteness, let us take $\varphi_2 = 0$ and $0 \neq \varphi_1 \equiv \varphi$. From (4.149), we see that $A_1 = \tilde{A}_1 = 0$, and so (4.150) admits a solution only if $k_1 = 0$. Let us suppose that

$$k_1 = 0. \quad (4.160)$$

Observe that the CS levels $(0, k_2)$ satisfy the parabolic condition on $J_0 J_{k_2}$, because $|\text{Tr}(J_0 J_{k_2})| = 2$ for any k_2 . Then the second equation of (4.150) implies that

$$(A_2)_I (\tilde{A}_2)^I = -2\varphi . \quad (4.161)$$

The fluxes (m_1, m_2) of the monopole operators $V_{(m_1, m_2)}$, satisfies $m_2 = 0$. For convenience, we write $m_1 = m$. The R -charge and the gauge charges of the monopole operators $V_{(m, 0)}$ are

$$\begin{aligned} R[V_{(m, 0)}] &= \frac{1}{2}(n_1|m| + n_2|0|) = \frac{1}{2}n_1|m| \\ q_1[V_{(m, 0)}] &= -[k_1(m) - 2(0)] = 0, \quad q_2[V_{(m, 0)}] = -[k_2(0) - 2(m)] = 2m . \end{aligned} \quad (4.162)$$

In this case the monopole operator $V_{(m, 0)}$ is no longer neutral under the gauge symmetry, but it carries charge $2m$ under the $U(1)_{k_2}$ gauge group. We can form the basic gauge invariant dressed monopole operators as follows:

$$(W^+)^{IJ} = V_{(1, 0)}(\tilde{A}_2)^I(\tilde{A}_2)^J, \quad (W^-)_{IJ} = V_{(-1, 0)}(A_2)_I(A_2)_J . \quad (4.163)$$

These operators transform under the representation $[2, 0, \dots, 0]$ and $[0, \dots, 0, 2]$ of $SU(n_2)$ respectively. They carry R -charges

$$R[W^\pm] = \frac{1}{2}n_1 + 1 , \quad (4.164)$$

and satisfy the quantum relation

$$\text{Tr}(W^+ W^-) = (W^+)^{IJ} (W^-)_{JI} = \varphi^{n_1+2} . \quad (4.165)$$

Since the dressed monopole operators W^\pm are generators of this branch of the moduli space, we can regard this as a ‘‘mixed’’ Higgs and Coulomb branch.

Note that if we take instead $\varphi_1 = 0$ and $0 \neq \varphi_2 \equiv \varphi$, the situation is reversed. In order for the vacuum equations to admit a solution we must have $k_2 = 0$. This leads to the gauge invariant dressed monopole operators

$$(U^+)^{IJ} = V_{(0, 1)}(\tilde{A}_1)^I(\tilde{A}_1)^J, \quad (U^-)_{IJ} = V_{(0, -1)}(A_1)_I(A_1)_J, \quad (4.166)$$

which transform under the representation $[2, 0, \dots, 0]$ and $[0, \dots, 0, 2]$ of $SU(n_1)$ respectively. They carry R -charges $R[U^\pm] = \frac{1}{2}n_2 + 1$ and satisfy the quantum relation $\text{Tr}(U^+ U^-) = \varphi^{n_2+2}$.

Finally, we remark that if $(k_1, k_2) = (0, 0)$, which is another possibility for $J_{k_1} J_{k_2}$ to be parabolic, then both dressed monopole operators W^\pm and U^\pm , as described above, are generators of the moduli space.

4.6 (p, q) -branes and J-fold theories

$T[U(N)]$ couplings are particularly useful in order to describe the field theories dual to brane configurations where more general $\binom{p}{q}$ -branes have been inserted. As before, we will focus on the case of a single D3 brane wrapping S^1 , in such a

way to reduce to Abelian Lagrangian theories. Let us consider for instance the following brane system

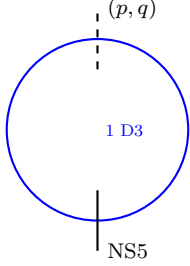

$$(4.167)$$

For simplicity, let us take (p, q) to be the following value: $(p, q) = \bar{J}_{k_3} \bar{J}_{k_2} \bar{J}_{k_1}(1, 0)$, so that¹¹

$$p = k_1 k_2 k_3 - k_1 - k_3, \quad q = k_1 k_2 - 1. \quad (4.168)$$

Since we are able to perform (local) $SL(2, \mathbb{Z})$ transformations, we can first apply the following duality transformation, $\bar{J}_{k_2}^{-1} \bar{J}_{k_3}^{-1}$ to the whole system and then perform a \bar{J}_{k_1} local transformation in the region where the $\binom{p}{q}$ -brane is located. We can study the following $SL(2, \mathbb{Z})$ equivalent problem:

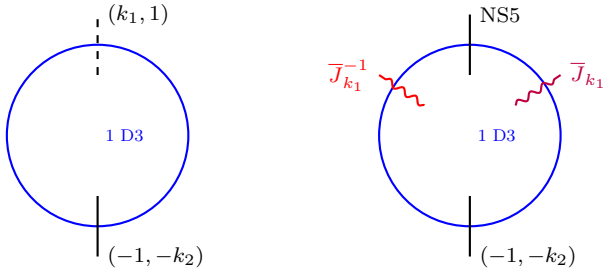

$$(4.169)$$

Let us observe that this equivalent setup does not depend at all by the choice of k_3 in (4.168). The associated quiver involves $T[U(1)]$ couplings. Let us stress again that we traded the problem of describing $\binom{p}{q}$ -brane system into the field-theoretical problem of $T[U(N)]$ interactions.

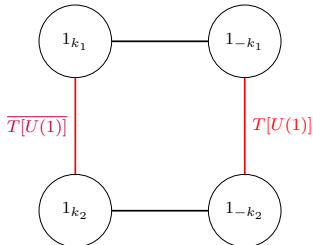

$$(4.170)$$

¹¹ \bar{J}_k is shorthand notation for $-J_{-k}$.

In $\mathcal{N} = 2$ language, this can be written as

$$(4.171)$$

The vacuum equations are

$$\begin{aligned}
A(\varphi_1 - \varphi_2) = 0 = \tilde{A}(\varphi_1 - \varphi_2), & & B(\varphi_3 - \varphi_4) = 0 = \tilde{B}(\varphi_3 - \varphi_4) \\
k_1\varphi_1 - \varphi_3 = A\tilde{A}, & & k_2\varphi_3 - \varphi_1 = B\tilde{B} \\
-k_1\varphi_2 + \varphi_4 = -A\tilde{A}, & & -k_2\varphi_4 + \varphi_2 = -B\tilde{B}.
\end{aligned}
\tag{4.172}$$

where we emphasized the contributions due to the mixed CS levels in blue. Observe that the only difference between $T[U(1)]$ and $\tilde{T}[U(1)]$ consists in the sign of the mixed Chern-Simons interaction. We have two branches, that we are going to analyze:

Branch I: $A\tilde{A} \neq 0$ and $B\tilde{B} \neq 0$

In this case the F -terms implies:

$$\varphi_1 = \varphi_2 = \varphi, \quad \varphi_3 = \varphi_4 = \tilde{\varphi}; \tag{4.173}$$

moreover, two constraints are still present, fixing φ , $\tilde{\varphi}$ in terms of the mesons:

$$k_1\varphi - \tilde{\varphi} = A\tilde{A}, \quad k_2\tilde{\varphi} - \varphi = B\tilde{B}. \tag{4.174}$$

An analogous analysis of the D-terms can be performed. The flux \mathbf{m} for the monopole operator $V_{\mathbf{m}}$ takes the form

$$\mathbf{m} = (m, m, \tilde{m}, \tilde{m}). \tag{4.175}$$

The gauge charges and the R -charges of $V_{\mathbf{m}}$ are

$$\begin{aligned}
q_1[V_{\mathbf{m}}] = -q_2[V_{\mathbf{m}}] = -(k_1m - \tilde{m}), \\
q_3[V_{\mathbf{m}}] = -q_4[V_{\mathbf{m}}] = -(k_2\tilde{m} - m).
\end{aligned}
\tag{4.176}$$

and

$$R[V_{\mathbf{m}}] = 0. \tag{4.177}$$

Let us now determine the moduli space and compute the Hilbert series of this theory. The baryonic generating function is given by

$$\begin{aligned}
G(t; B, \tilde{B}) &= \left(\prod_{i=1}^4 \oint \frac{dq_i}{2\pi i q_i} \right) \frac{1}{q_1^B q_2^{-B} q_3^{\tilde{B}} q_4^{-\tilde{B}}} \text{PE}[t(q_1 q_2^{-1} + q_2 q_1^{-1})] \text{PE}[t(q_3 q_4^{-1} + q_4 q_3^{-1})] \\
&= g_{\text{ABJM}/2}(t; B) g_{\text{ABJM}/2}(t; \tilde{B}).
\end{aligned}
\tag{4.178}$$

where

$$g_{\text{ABJM}/2}(t; B) = \frac{t^{|B|}}{1-t^2} . \quad (4.179)$$

The Hilbert series of (4.171) is thus:

$$\begin{aligned} H_{(4.171)}(t, z) &= \sum_{m \in \mathbb{Z}} \sum_{\tilde{m} \in \mathbb{Z}} z^{m+\tilde{m}} g_{\text{ABJM}/2}(t; k_1 m - \tilde{m}) g_{\text{ABJM}/2}(t; k_2 \tilde{m} - m) \\ &= \sum_{m \in \mathbb{Z}} \sum_{\tilde{m} \in \mathbb{Z}} z^{m+\tilde{m}} \frac{t^{|k_1 m - \tilde{m}|}}{1-t^2} \frac{t^{|k_2 \tilde{m} - m|}}{1-t^2} . \end{aligned} \quad (4.180)$$

This turns out to be equal to

$$\begin{aligned} H_{(4.171)}(t, z) &= \frac{1}{k_1 k_2 - 1} \sum_{j=1}^{k_1 k_2 - 1} \frac{1}{(1-t u_j)(1-t w_j)} \frac{1}{(1-t/u_j)(1-t/w_j)} \\ &= H[\mathbb{C}^4 / \Gamma(k_1, k_1 k_2 - 1)](t, z) , \end{aligned} \quad (4.181)$$

where

$$u_j = z^{\frac{k_1+1}{k_1 k_2 - 1}} e^{j \frac{2\pi i k_1}{k_1 k_2 - 1}} , \quad w_j = z^{\frac{k_2+1}{k_1 k_2 - 1}} e^{j \frac{2\pi i}{k_1 k_2 - 1}} . \quad (4.182)$$

This is the Molien formula for the Hilbert series of $\mathbb{C}^4 / \Gamma(\mathbf{p}, \mathbf{q})$ [68], with $\mathbf{p} = k_1$ and $\mathbf{q} = k_1 k_2 - 1$, where $\Gamma(\mathbf{p}, \mathbf{q})$ is a discrete group acting on the four complex coordinate of \mathbb{C}^4 as:

$$\Gamma(\mathbf{p}, \mathbf{q}) : (z_1, z_2, z_3, z_4) \rightarrow (z_1 e^{\frac{2\pi i \mathbf{p}}{\mathbf{q}}}, z_2 e^{\frac{2\pi i}{\mathbf{q}}}, z_3 e^{-\frac{2\pi i \mathbf{p}}{\mathbf{q}}}, z_4 e^{-\frac{2\pi i}{\mathbf{q}}}) . \quad (4.183)$$

This is in agreement with [61, 69].

Branch II: $A\tilde{A} = 0$ or $B\tilde{B} = 0$

The second branch appears when we set one of the bi-fundamental hypers to zero, say $A\tilde{A} = 0$. In this case, (4.172) implies again that:

$$\varphi_1 = \varphi_2 = \varphi, \quad \varphi_3 = \varphi_4 = \tilde{\varphi}. \quad (4.184)$$

Moreover, we have¹²:

$$k_1 \varphi = \tilde{\varphi}, \quad k_2 \tilde{\varphi} - \varphi = B\tilde{B}. \quad (4.185)$$

Because of $\mathcal{N} = 3$ supersymmetry of the problem, the real scalar in the vector multiplet satisfies the same equation as the complex scalar in the vector multiplet. As a consequence, the flux $\mathbf{m} = (m, m, \tilde{m}, \tilde{m})$ of the monopole operator $V_{\mathbf{m}}$ has to satisfy

$$k_1 m = \tilde{m} \quad (4.186)$$

The gauge charges of $V_{\mathbf{m}}$ are

$$\begin{aligned} q_1[V_{\mathbf{m}}] &= -q_2[V_{\mathbf{m}}] = -(k_1 m - \tilde{m}) = 0, \\ q_3[V_{\mathbf{m}}] &= -q_4[V_{\mathbf{m}}] = -(k_2 \tilde{m} - m) = -(k_1 k_2 - 1)m . \end{aligned} \quad (4.187)$$

¹²A special case is $k_1 = k_2 = \pm 1$. In this case $B\tilde{B} = 0$ and we are left with φ and the basic monopole operators. The corresponding moduli space is thus simply \mathbb{C}^2 .

The R -charge of V_m is $R[V_m] = 0$. The gauge invariant dressed monopole operators are

$$\bar{V}_+ = V_{(1,1,k_1,k_1)} B^{k_1 k_2 - 1}, \quad \bar{V}_- = V_{(-1,-1,-k_1,-k_1)} \tilde{B}^{k_1 k_2 - 1}, \quad (4.188)$$

for $k_1 k_2 - 1 > 0$. If $k_1 k_2 - 1 < 0$, we replace $B^{k_1 k_2 - 1}$ by $\tilde{B}^{-(k_1 k_2 - 1)}$ and $\tilde{B}^{k_1 k_2 - 1}$ by $B^{-(k_1 k_2 - 1)}$ in the above equations. They carry R -charges $R[\bar{V}_\pm] = \frac{|k_1 k_2 - 1|}{2}$. Since $(k_1 k_2 - 1)\varphi = B\tilde{B}$, we see that these dressed monopole operators satisfy the quantum relation

$$\bar{V}_+ \bar{V}_- = \varphi^{|k_1 k_2 - 1|}. \quad (4.189)$$

Hence the moduli space is $\mathbb{C}^2/\mathbb{Z}_{|k_1 k_2 - 1|}$.

Note that (4.186) implies that the magnetic lattice given by \tilde{m} jumps by a multiple of k_1 , since $m \in \mathbb{Z}$. If we further require that the magnetic lattice do not jump, we can impose a further condition that $k_1 = \pm 1$. In this case, the brane system contains a $(\pm 1, 1)$ -brane and a $(-1, -k_2)$ -brane. Applying $T^{\mp 1}$ to this system, $(\pm 1, 1)$ becomes $(\pm 1, 0)$, and $(-1, k_2)$ becomes $(-1, -k_2 \mp 1)$. This gives rise to the ABJM theory with CS level $k_2 - 1$ and $-k_2 + 1$. Indeed, Branch I (which is $\mathbb{C}^4/\mathbb{Z}_{|k_2 - 1|}$) and Branch II (which is $\mathbb{C}^2/\mathbb{Z}_{|k_2 - 1|}$) are the so-called geometric branch of the ABJM theory and the moduli space of the half-ABJM theory, respectively.

Chapter 5

Variations on S-fold CFTs

Up to now, we only considered S-fold SCFTs with a $T[U(N)]$ link. These are dual to compact Hanany-Witten configurations where an S-fold has been inserted. It is interesting to observe that $T[U(N)]$ theories admit a generalization, $T[G]$, where G is an arbitrary simple Lie group. Following [15], we can think of a $T[G]$ theory in the following way: let us consider a Janus configuration in four dimensions. The space, with coordinates $\{x^{0,1,2}, t\}$, is divided into two regions: in the half-space $t < 0$ a weakly coupled 4d SYM with gauge group G lives, while for $t > 0$ physics is described by a strongly coupled 4d SYM with gauge group G . In order to deal with the strongly coupled sector, we can perform a local S-duality transformation, so that in $t > 0$ we end up with a weakly coupled theory consisting of 4d SYM theory with gauge group G^\vee [70], the Langlands dual group of G , coupled to some boundary theory at the interface. Flowing in the IR, the four-dimensional vectors are frozen and we only observe a three-dimensional field theory with symmetry group $G \times G^\vee$; the two factors act on Higgs and Coulomb branch respectively. The two cones coincides with the maximal nilpotent orbits \mathcal{N}_G and \mathcal{N}_{G^\vee} . This construction can be understood as a formal definition of $T[G]$. Whenever $G = G^\vee$, *i.e.* in the case of self-Langlands groups, $T[G]$ is a self-mirror theory; otherwise, mirror symmetry maps $T[G]$ into $T[G^\vee]$.¹ In the case of classical real groups, the unique self-dual theories corresponds to $G = SO(2N), USp'(2N)$, whose quiver realization are illustrated below:

$$T[SO(2N)] : \quad \boxed{2N} - \textcircled{2N-2} - \textcircled{2N-2} - \textcircled{2N-4} - \dots - \textcircled{2} - \textcircled{2} \quad (5.1)$$

$$T[USp'(2N)] : \quad \boxed{2N} - \textcircled{2N-1} - \textcircled{2N-2} - \textcircled{2N-3} - \dots - \textcircled{2} - \textcircled{1} \quad (5.2)$$

¹ $T_\rho^\sigma[G]$ also exists [15]. It must be stressed that in this case ρ is a Young tableau defining an embedding of $\mathfrak{su}(2)$ into \mathfrak{g} , while σ defines an $\mathfrak{su}(2)$ embedding into \mathfrak{g}^\vee . Moreover, not all possible tableaux define a good embedding. Some examples can be found in [49]. For the exceptional groups, it is not possible at all to use the tableaux in order to define the orbits

We introduced the following convention to distinguish the nodes corresponding to various groups:

$$\begin{aligned}
U(N) : & \quad \textcircled{N} & \quad \boxed{N} \\
USp(M) : & \quad \textcircled{M} & \quad \boxed{M} \quad \text{with } M \text{ even} \\
O(K) \text{ or } SO(K) : & \quad \textcircled{K} & \quad \boxed{K}
\end{aligned} \tag{5.3}$$

We shall be explicit whenever we would like to emphasize whether the group is $O(k)$ or $SO(k)$. Moreover, let us stress that a $SO(2N)$ is always followed by an $USp(M)$ node while an $SO(2N+1)$ node is followed by a $USp'(2N)$ node so that no ambiguities can arise. For sake of clarity, sometimes we will use also the notation $2N'$ inside blue node in order to specify a $USp'(2N)$ gauge group. $T[SO(2N+1)]$ and $T[USp(2N)]$ form instead a mirror pair. Their quiver realization is the following:

$$T[SO(2N+1)] : \quad \boxed{2N+1} - \textcircled{2N} - \textcircled{2N-1} - \textcircled{2N-2} - \dots - \textcircled{2} - \textcircled{1} \tag{5.4}$$

$$T[USp(2N)] : \quad \boxed{2N} - \textcircled{2N} - \textcircled{2N-2} - \textcircled{2N-2} - \dots - \textcircled{2} - \textcircled{2} \tag{5.5}$$

Compact models with classical real groups can be engineered at brane level inserting an O3-plane (wrapping an S^1) or two O5-planes into a Hanany-Witten configuration [71–73]. These brane systems do not possess at the moment a supergravity realization. In this section, we are interested in understanding whether S-fold SCFTs admit a generalization where a $T[U(N)]$ link is substituted by a more general $T[G]$ link. Following the guiding lines of section 4, we will study the moduli space of models involving different classical real groups, trying to understand which kind of constraints are imposed by the required consistency with mirror symmetry. We also propose a new class of circular mirror pairs involving G_2 gauge groups.

Some computations performed in this chapter make use of some technical results about the hyperkähler spaces arising from the coupling of hypermultiplets to nilpotent cones. In order to make our discussion lighter, we collected such technical results in the appendix (A.2).

5.1 Hanany-Witten systems with O-planes

In HW brane configurations we can only insert O3 and O5 planes in order to preserve supersymmetry. In both case, O-planes are fixed loci of a \mathbb{Z}_2 involution. Quotient with respect to such involution implies that Chan-Paton dressing of a string ending on a $D3$ -brane must be performed in a symmetric or antisymmetric way: fluctuations of those strings must be interpreted as vector multiplets for classical real groups.

5.1.1 O3-plane

Let us consider a configuration where an O3-plane is put on top of $2N$ D3-branes wrapping an S^1 .² We actually have four different kinds of possible O3-planes, denoted by $O3^\pm$ and $\widetilde{O3}^\pm$ [56, 72]. Each plane differs from the others for its D3-brane charge and the discrete torsion for the NS and RR two-form connections. Without entering into details, we can think the two torsion classes in terms of fluxes through a compact two-cycles in the given background:

$$(n_{NS}, n_{RR}) = \left(\frac{1}{2\pi i} \int_{S^2} B, \frac{1}{2\pi i} \int_{S^2} C_2 \right) \in (\mathbb{Z}_2, \mathbb{Z}_2), \quad (5.6)$$

where n_{NS} and n_{RR} are swapped by S-duality transformation. On each kind of O-plane, a different gauge group is realized. We collected the feature of the four O3-planes in the table (5.7).

	(n_{NS}, n_{RR})	D3 charge	$G_{(n_{NS}, n_{RR})}$	S-dual	
$O3^-$	(0, 0)	-1/4	$SO(2N)$	$O3^-$	(5.7)
$\widetilde{O3}^-$	(0, 1)	+1/4	$SO(2N+1)$	$O3^+$	
$O3^+$	(1, 0)	+1/4	$USp(2N)$	$\widetilde{O3}^-$	
$\widetilde{O3}^+$	(1, 1)	+1/4	$USp'(2N)$	$\widetilde{O3}^+$	

Observe that we can think to divide a 5-brane into two half-branes, one being the mirror of the other under orientifold involution. When the two halves are brought on the orientifold plane, they combine to give a full 5-brane again. However, we can also consider half-branes without a companion, stuck at the orientifold plane.

Conservation of flux integers implies that any time an O3-plane is cut by a $1/2$ NS5-brane, n_{RR} has to jump by 1. Thus, in a Hanany-Witten configuration we find a series of alternating $O3^+ - O3^-$ planes or $\widetilde{O3}^+ - \widetilde{O3}^-$ planes. Moreover, in a circular configuration made out of an O3-plane on top of $2N$ D3 branes we can only insert an even number of $1/2$ NS5-branes. In an analogous way, any time a $1/2$ D5-brane cuts a D3-brane, n_{NS} must jump by 1 and an $O3^\pm$ plane must change into an $\widetilde{O3}^\pm$ one and vice-versa. In a circular quiver, the number of $1/2$ D5-branes that can be inserted in each segment must be consistent with all the alternation rules we have presented. Let us assume that in a given segment with an O3-plane of fluxes (n_{NS}, n_{RR}) additional N_f $1/2$ D5-branes are added. From a quiver perspective, these must be interpreted as n_f fundamental flavors rotated among them by the action of the global symmetry $G_{(n_{NS}+1, n_{RR}+1)}$.³ As an example, let us present a brane configuration consisting of an $O3^\pm$ -plane on top $2N$ D3 branes wrapping S^1 , two half NS5-branes (forcing the plane to change type) and f $1/2$ D5-brane; the dual field theory consists a $SO(2N) \times USp(2N)$ gauge theory with two bi-fundamentals and f flavors for the $USp(2N)$ gauge

²D3-branes always come in pairs. One of the two D3s can be understood as the image under the orientifold involution.

³For instance, given a gauge node USp' (i.e. $(n_{NS}, n_{RR}) = (1, 1)$), N_f flavors transform in the fundamental representation of $SO(2N_f)$ (i.e. $(n_{NS} + 1, n_{RR} + 1) = (0, 0)$).

node:

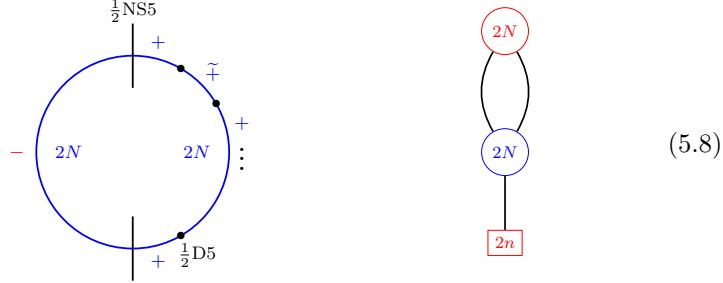

The mirror configuration can be determined using the rules summarized in (5.7). The dual field theory is much more complicated in this case and contains $SO(2N)$, $SO(2N + 1)$ and $USp'(2N)$ gauge nodes, as shown in figure (5.9).

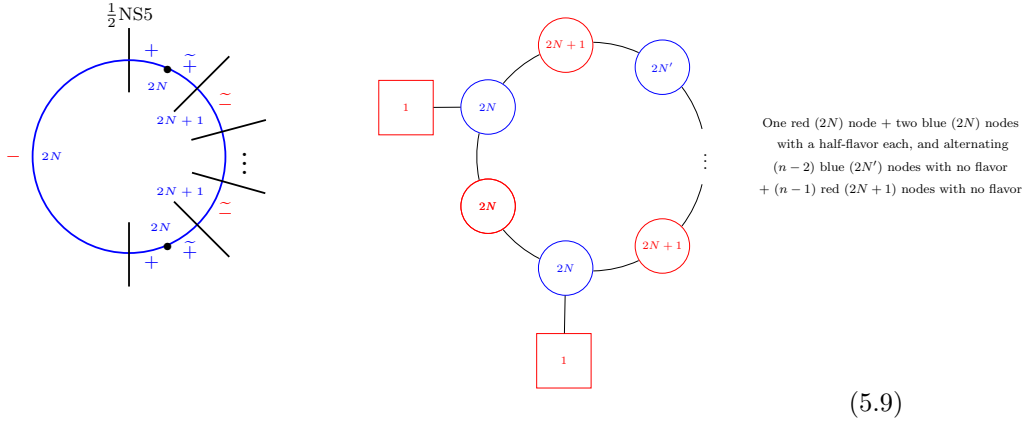

One red $(2N)$ node + two blue $(2N)$ nodes with a half-flavor each, and alternating $(n - 2)$ blue $(2N')$ nodes with no flavor + $(n - 1)$ red $(2N + 1)$ nodes with no flavor

The single flavors transforming in the fundamental representation of the two $USp(2N)$ gauge nodes must be understood as half-hypers. Half-hypers can be built starting from a full hypermultiplet (Q_a, \tilde{Q}^a) with a gauge indices. Let us assume Q to transform in a pseudo-real representation \mathcal{R} and \tilde{Q} in the conjugate one, $\bar{\mathcal{R}}$. Since the representation is pseudo-real, there exists an anti-symmetric rank-two tensor ϵ_{ab} . Using this tensor, we can impose the condition $\tilde{Q}_a = \epsilon_{ab} \tilde{Q}^b$, halving the numbers of degrees of freedom.

5.1.2 O5-planes

O5-planes span the same direction as NS5 or D5 branes. In particular the orientifold involution identifies x^6 with $-x^6$ (see table (2.52)). Let us consider a Hanany Witten configuration with N D3-branes wrapping an S^1 and two O5-plane spanning either $x^{3,4,5}$ (*i.e.* parallel to NS5-branes) or $x^{7,8,9}$ (*i.e.* parallel to D5-branes). Between the two planes, an arbitrary number of NS5 and D5 branes can be added. However because of the two orientifold involutions, the two intervals between the O5-planes must be identified, as illustrated in figure

(5.10).

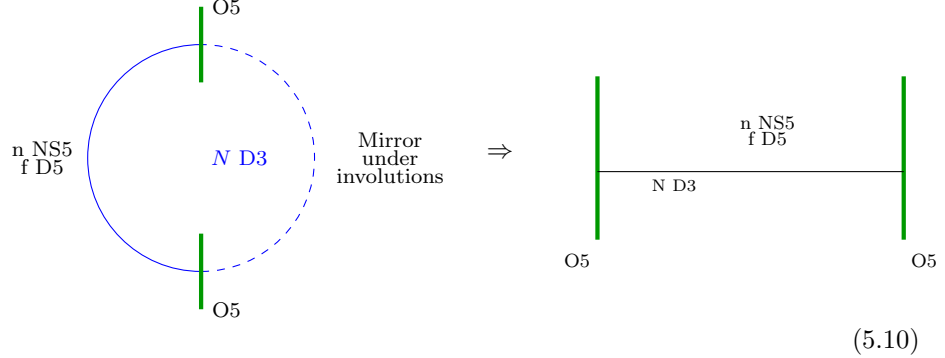

Thus, in the following, we will consider quivers that are only apparently linear, but they must be actually understood as circular compact models. As in the $O3$ -plane case, $O5$ -planes come in four varieties, $O5^\pm$ and ON^\pm ; the pairs $\{ON^\pm, O5^\pm\}$ are related by S-duality. In the rest of the chapter, we will focus on the minus case.⁴ The $O5^-$ planes span the same directions as an NS5 brane. Let us explain how quiver gauge theory can be read from a given Hanany-Witten configuration. With respect to the case without O-planes, we must only understand the gauge node and flavor matter arising from the segment of D3 ending on the plane. There are two possibilities [73, 76]:

- N D3-branes end on an $O5^-$ -plane with no NS5-branes on top. In this case, because of the O-plane involution, strings fluctuations describe an $USp(2N)$ vector multiplet. Moreover, additional f D5-branes translate into f flavor hypermultiplets rotated by an $SO(2f)$ global symmetry group. For instance, we can consider the model in (5.11), made of two $O3^-$ planes and f D5-branes; the dual field theory is nothing but $3d \mathcal{N} = 4$ $USp(2N)$ gauge theory with f flavors:

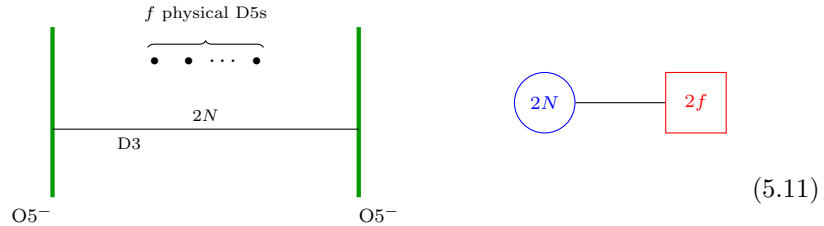

- N D3-branes stretch between an $O5^-$ plane with an NS5 on top and another NS5 brane. In this case the gauge group is again $U(N)$ and D5-branes are interpreted as fundamental hypermultiplets; however, there is an additional rank two antisymmetric hypermultiplet: this situation is depicted in figure (5.12). The model is made of two $O5^-$ plane with NS5s on top and f D5-branes. The dual field theory is a $3d \mathcal{N} = 4$ $U(N)$ gauge

⁴Describing the dual quiver when an ON^+ is present requires the introduction of non-Lagrangian matter [74, 75]. In order to keep our discussion lighter, we will avoid this further complication. However, analysis of the moduli space of such models (with and without S-folds) can be found in [31, 74].

theory with f fundamental flavor and two rank-two antisymmetric hyps A and A' (one for each plane).

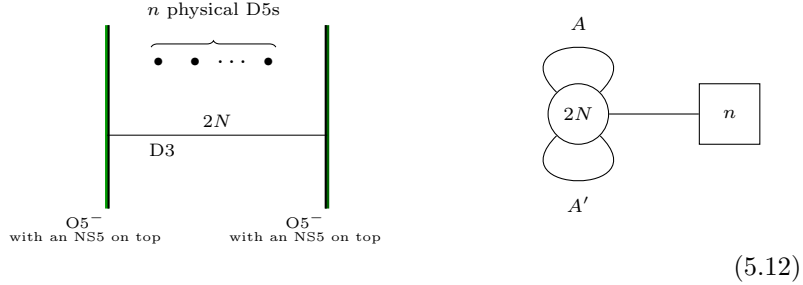

Configurations dual to brane setup with $O3^-$ planes involve ON^- planes, eventually with D5-branes on top.⁵ For instance, the configuration dual to (5.11) is the following:

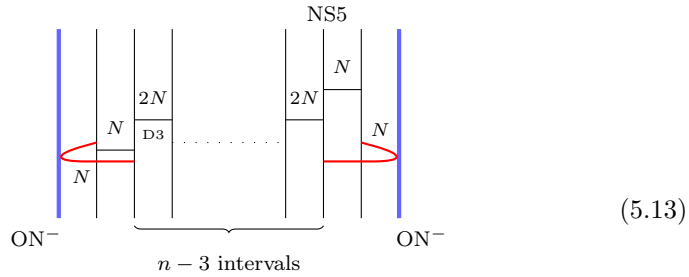

In (5.13), the two (red) stacks of D3-branes in the first segment represent N D3s and their mirror under orientifold involution. They do not participate in any way to the dynamics and must be considered as frozen. In the next segment, we can find again two stacks of N D3-branes, that translates into two $U(N)$ gauge nodes at the quiver level. The field theory dual to the setup in (5.13) is the following:

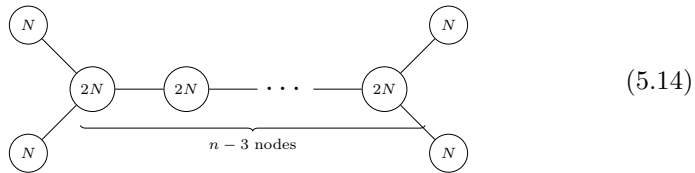

Whenever a D5-brane is put on top of a ON^- plane, we must also take into account of the degrees of freedom brought by strings stretching between the N (black) D3-branes in the second segment of (5.13) and the D5: these fluctuations translate into an additional flavor hypermultiplet transforming in the fundamental representation of one of the extremal $U(N)$ nodes. Below, we illustrated the

⁵In fact, ON^- planes span the same directions as a D5-brane.

configuration and field theory dual to (5.12):

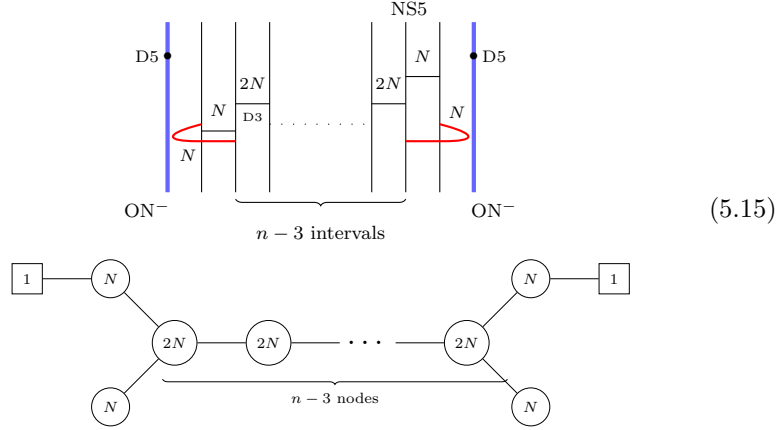

5.2 S-fold models with an orientifold threeplane

In this section, we want to provide evidence that an S-fold can be inserted in a consistent way into Hanany-Witten setup where an O3 plane has been inserted on top of N D3-branes wrapping S^1 . From a quantum field theory side, we propose that the dual field theories consist of S-fold CFTs where the global symmetries of a $T[G]$ theory have been gauged, with G classical real group. All the proposed model must be consistent against mirror symmetry. We check our proposal studying the moduli spaces of some classes of interesting models.

An important result and observation is that S-fold SCFTs can be constructed only gauging the global symmetries of a self-Langlands group, *i.e.* the unique admitted T-links are $T[SO(2N)]$ and $T[USp'(2N)]$. Otherwise, we obtain brane configurations that cannot be consistent with (5.7) and the rules that we have presented before. For instance, let us consider a circular quiver with the $USp(4) \times SO(4) \times USp(4) \times SO(5)$ gauge group, where the first $USp(4)$ and the last $SO(5)$ are connected by the T-link and other groups are connected by bifundamental half-hypermultiplets. One cannot realize this theory using a Type-IIB brane configuration with an orientifold threeplane and an “S-fold” in a simple way for the following reason. Note that the first $USp(4)$ and the last $SO(5)$ connected by the T-link must be associated with $O3^+$ and $\widetilde{O3}^-$ respectively, and as the O3 plane crosses a half-NS5 brane it changes sign. Starting from the left $USp(4)$ as we go through the sequence of the gauge groups to the right, we obtain the sequence of the associated O3 plane to be $(O3^+, O3^-, O3^+, O3^-)$. However, this is in contradiction with the fact that the $SO(5)$ gauge group must be associated with $\widetilde{O3}^-$, and not $O3^-$. Thus, there is no way to construct a consistent brane configuration.

Another possible configuration that one could imagine is the following:

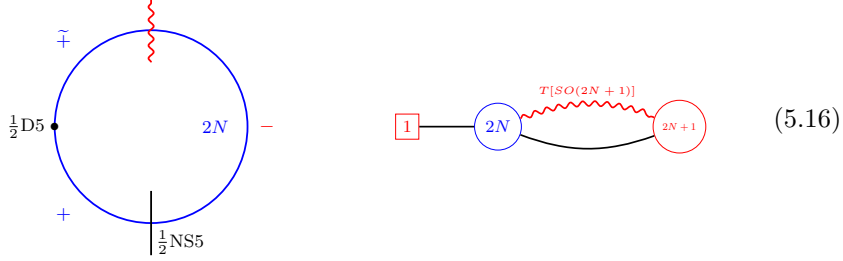

The $USp(2N)$ node has an odd number of flavors and this is source of parity anomaly that we can only cancel turning on a non-trivial Chern-Simons level [10]. However, since we want to consider S-flip theories only, where we know how to perform computations, we need to exclude this class of model also. One can convince itself that any other possible model suffers of the same kind of problems. In the rest of the section we will study the moduli space of some interesting examples and in particular we will show that the freezing rule conjecture proposed in [29] and described 4 extends to this case.

All along this chapter, we will denote T-links with a red wiggly line.

5.2.1 Quiver with a $T[SO(2N)]$ loop

We start by examining the following brane configuration and the corresponding quiver:

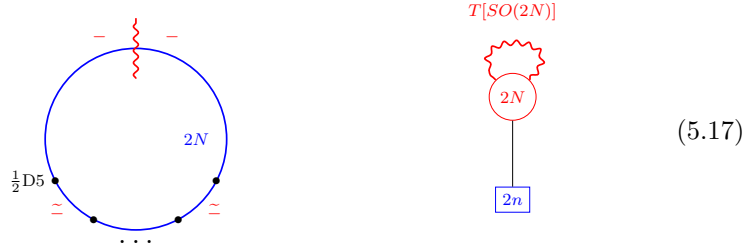

where in the left diagram the red wiggly denotes the S -fold and there are $2n$ half D5 branes. In order to obtain the mirror theory, we apply S -duality to the above brane system. The result is

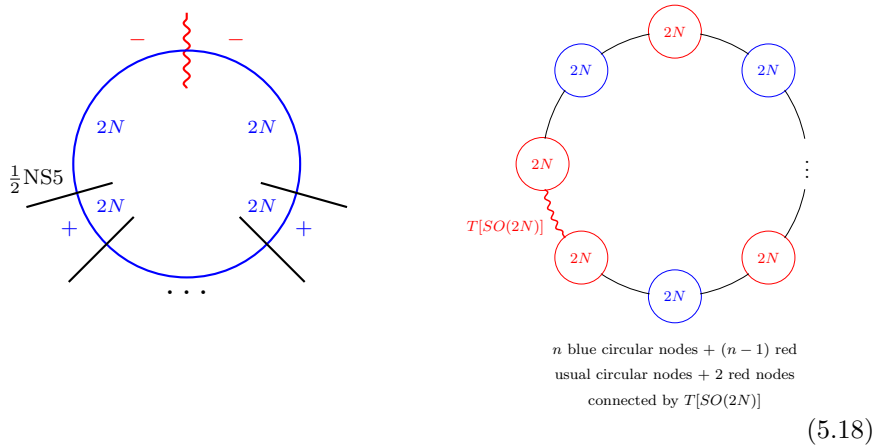

where in the left diagram there are $2n$ half-NS5 branes.

In the absence of the S -fold, quivers (5.17) and (5.18) reduce to conventional Lagrangian theories that are related to each other by mirror symmetry. In particular, (5.17) reduces to a theory of free $4Nn$ half-hypermultiplets, namely

$$\boxed{2N} \text{ --- } \boxed{2n} \quad (5.19)$$

and quiver (5.18) reduces to

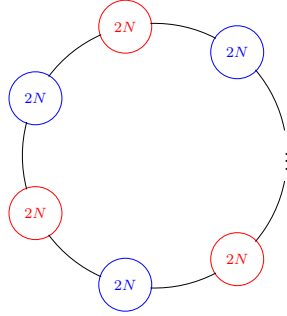

$$(5.20)$$

where the two $SO(2N)$ gauge groups that were connected by $T[SO(2N)]$ merged into a single $SO(2N)$ circular node. It can be checked that the Higgs branch dimension of (5.20) is indeed zero:

$$(2n)(2N^2) - n \left[\frac{1}{2}(2N)(2N - 1) \right] - n \left[\frac{1}{2}(2N)(2N + 1) \right] = 0 , \quad (5.21)$$

and the quaternionic dimension of the Coulomb branch of (5.20) is $2Nn$. These are in agreement with mirror symmetry.

Theory (5.17)

The Higgs branch of this theory is given by the hyperkähler quotient:

$$\mathcal{H}_{(5.17)} = \frac{\mathcal{N}_{so(2N)} \times \mathcal{N}_{so(2N)} \times \mathcal{H}([S/O(2N)] - [USp(2n)])}{S/O(2N)} . \quad (5.22)$$

where the notation S/O means that we may take the gauge group to be $SO(2N)$ or $O(2N)$. The dimension of this space is

$$\dim_{\mathbb{H}} \mathcal{H}_{(5.17)} = \left[\frac{1}{2}(2N)(2N - 1) - N \right] + 2Nn - \frac{1}{2}(2N)(2N - 1) = (2n - 1)N . \quad (5.23)$$

Since the circular nodes that are connected by $T[SO(2N)]$ do not contribute to the Coulomb branch, it follows that the Coulomb branch of (5.17) is trivial:

$$\dim_{\mathbb{H}} \mathcal{C}_{(5.17)} = 0 . \quad (5.24)$$

Let us now discuss certain interesting special cases below.

The Higgs branch of (5.17) for $N = 1, 2$

For $N = 1$, since $\mathcal{N}_{so(2)}$ is trivial, it follows that $\mathcal{H}_{(5.17)}$ is the Higgs branch of the 3d $\mathcal{N} = 4$ $S/O(2)$ gauge theory with n flavors. If the gauge group is taken to be $O(2)$, $\mathcal{H}_{(5.17)}$ is isomorphic to the closure of the minimal nilpotent orbit of $usp(2n)$. On the other hand, if the gauge group is taken to be $SO(2)$, $\mathcal{H}_{(5.17)}$ turns out to be isomorphic to the closure of the minimal nilpotent orbit of $su(2n)$. The reason is because the generators of the moduli space with $SU(2)_R$ -spin 1 are mesons and baryons; they transform in the representation $[2, 0, \dots, 0] + [0, 1, 0, \dots, 0]$ of $usp(2n)$. This representation combines into the adjoint representation $[1, 0, \dots, 0, 1]$ of $su(2n)$.

For $N = 2$, let us denote the fundamental half-hypermultiplets by Q_a^i with $i, j, k, l = 1, \dots, 2n$ and $a, b, c, d = 1, 2, 3, 4$, and the generators of $\mathcal{N}_{so(4)}$ by a rank-two antisymmetric tensor X_{ab} . We find that for the $O(4)$ gauge group, the generators of the Higgs branch are as follows:

- The mesons $M^{ij} = Q_a^i Q_b^j \delta^{ab}$, with $SU(2)_R$ -spin 1, transforming in the adjoint representation $[2, 0, \dots, 0]$ of $usp(2n)$.
- The combinations $Q_a^i Q_b^j X_{ab}$, with $SU(2)_R$ -spin 2, transforming in the adjoint representation $[0, 1, 0, \dots, 0]$ of $usp(2n)$.

For the $SO(4)$ gauge group, we have, in addition to the above, the following generators of the Higgs branch:

- The baryons $B^{ijkl} = \epsilon^{abcd} Q_a^i Q_b^j Q_c^k Q_d^l$, with $SU(2)_R$ -spin 2, transforming in the adjoint representation $[0, 0, 0, 1, 0, \dots, 0] + [0, 1, 0, \dots, 0]$ of $usp(2n)$.
- The combinations $\epsilon^{abcd} Q_a^i Q_b^j X_{cd}$, with $SU(2)_R$ -spin 2, transforming in the adjoint representation $[0, 1, 0, \dots, 0]$ of $usp(2n)$.
- The $USp(2n)$ flavor singlet $\epsilon^{abcd} X_{ab} X_{cd}$, with $SU(2)_R$ -spin 2.

The Higgs branch of (5.17) for $n = 1$

In this case, it does not matter whether we take the gauge group to be $SO(2N)$ or $O(2N)$, the Higgs branch is the same. The corresponding Hilbert series is

$$H[\mathcal{H}_{(5.17)}|_{n=1}] = \text{PE} \left[\chi_{[2]}^{su(2)}(x) \sum_{j=0}^{N-1} t^{4j+2} - \sum_{l=N}^{2N-1} t^{4l} \right]. \quad (5.25)$$

Indeed, for $N = n = 1$, we recover the nilpotent cone of $su(2)$, which is isomorphic to $\mathbb{C}^2/\mathbb{Z}_2$.

Theory (5.18)

Since the nodes that are connected by $T[SO(2N)]$ do not contribute to the Coulomb branch, it follows that the dimension of the Coulomb branch is

$$\mathcal{C}_{(5.18)} = (2n - 1)N. \quad (5.26)$$

Note, however, that quiver (5.18) is a ‘‘bad’’ theory in the sense of [15], due to the fact that each $USp(2N)$ gauge group has $2N$ flavors. Nevertheless, we shall

analyze the case of $n = 1$ and general N in detail below. In which case, we shall see that the result is consistent with mirror symmetry.

The computation of the Higgs branch dimension of (5.18) indicates that the gauge symmetry is not completely broken at a generic point of the Higgs branch. Indeed, if we assume (incorrectly) that the gauge symmetry is completely broken, we would obtain the $\dim_{\mathbb{H}} \mathcal{H}_{(5.18)}$ to be

$$(5.21) + \left[\frac{1}{2}(2N)(2N - 1) - N \right] - \frac{1}{2}(2N)(2N - 1) = -N . \quad (5.27)$$

We conjecture that the $SO(2N) \times SO(2N)$ gauge group connected by $T[SO(2N)]$ is broken to $SO(2)^N$, whose dimension is N . This statement can be checked explicitly in the case of $N = 1$, where $T[SO(2)]$ is trivial. Taking into account such an unbroken symmetry, we obtain $\dim_{\mathbb{H}} \mathcal{H}_{(5.18)} = 0$, which is in agreement with the Coulomb branch of (5.17).

5.2.2 Quivers with a $T[SO(2N)]$ link or a $T[USp'(2N)]$ link

Let us consider the following triangular configuration:

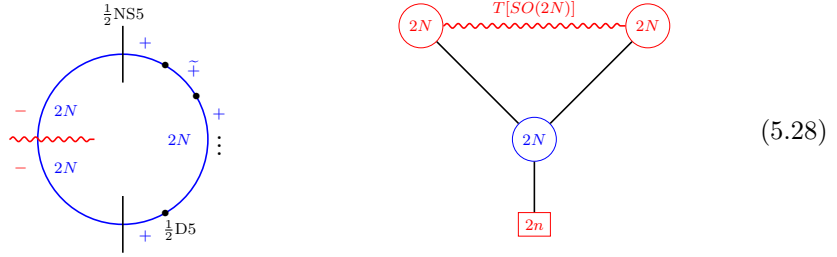

The mirror theory consists of a complicated circular model made of several gauge nodes and two fundamental half hypermultiplets:

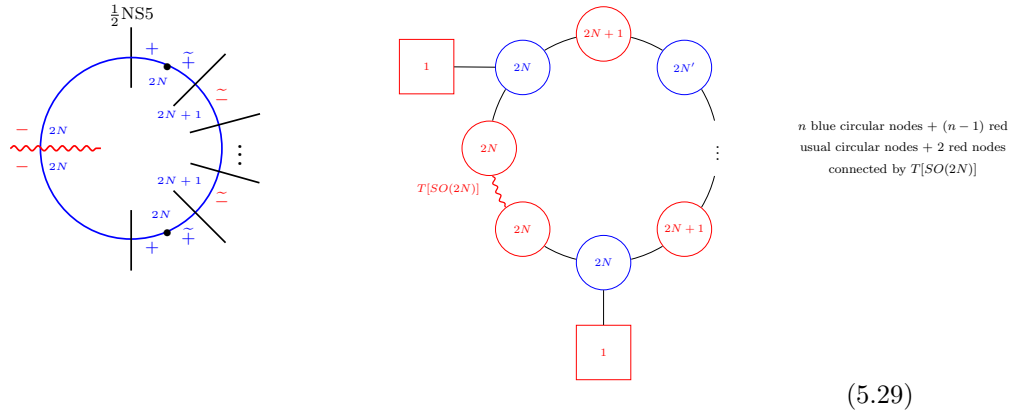

Note that for $n = 1$, the theory is self-mirror.

Theory (5.28)

The Higgs branch of (5.28) is described by the hyperkähler quotient

$$\begin{aligned} \mathcal{H}_{(5.28)} &= \left(\mathcal{N}_{so(2N)} \times \mathcal{H}([SO(2N)] - [USp(2N)]) \times \mathcal{N}_{so(2N)} \times \mathcal{H}(SO(2N) - [USp(2N)]) \times \right. \\ &\quad \left. \mathcal{H}([USp(2N)] - [SO(2n)]) \right) / (SO(2N) \times SO(2N) \times USp(2N)) \\ &= \frac{\mathcal{N}_{usp(2N)} \times \mathcal{N}_{usp(2N)} \times \mathcal{H}([USp(2N)] - [SO(2n)])}{USp(2N)}, \end{aligned} \quad (5.30)$$

where we have used (A.30) to obtain the last line. We remark that both red circular nodes can be chosen to be either $SO(2N)$ or $O(2N)$ and the results for both options are the same, thanks to the equality between (A.30) and (A.36). Moreover, the hyperkähler quotient in the last line of (5.30) suggests the equality between (5.30) and the Higgs branch of the following theory:

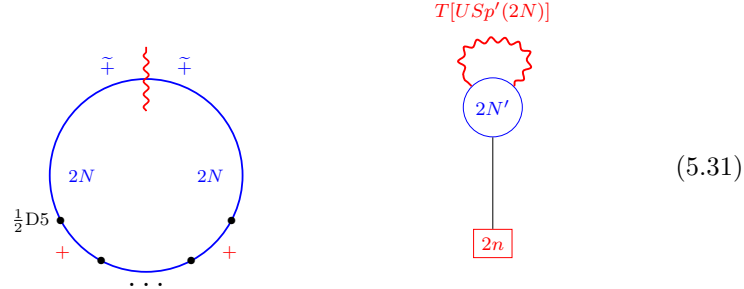

(5.31)

where the blue circular node is a $USp'(2N)$ gauge group. In other words, we have the following equality of the Higgs branch between two different gauge theories:

$$\mathcal{H}_{(5.28)} = \mathcal{H}_{(5.31)}. \quad (5.32)$$

The quaternionic dimension of (5.30) is

$$\begin{aligned} \dim_{\mathbb{H}} \mathcal{H}_{(5.28)} &= \left[\frac{1}{2}(2N)(2N-1) - N \right] + 2(4N^2) + 2Nn \\ &\quad - \left[2 \times \frac{1}{2}(2N)(2N-1) \right] - \frac{1}{2}(2N)(2N+1) \\ &= (2n-1)N. \end{aligned} \quad (5.33)$$

Since the nodes that are connected by $T[SO(N)]$ does not contribute to the Coulomb branch of the theory, the Coulomb branch of (5.28) is isomorphic to the Coulomb branch of the 3d $\mathcal{N} = 4$ $USp(2N)$ gauge theory with $2N + n$ flavors, whose Hilbert series is given by [30, (5.14)]. Its quaternionic dimension is

$$\dim_{\mathbb{H}} \mathcal{C}_{(5.28)} = N. \quad (5.34)$$

Example: $n = 1$. The theory is self-mirror. One can check that the Hilbert series of the quotient (5.30) is indeed equal to the Coulomb branch of $USp(2N)$ gauge theory with $2N + 1$ flavors [30, (5.14)], which is

$$\text{PE} \left[\sum_{j=1}^{2N} t^{2j} + \sum_{j=1}^N t^{4j} - \sum_{j=1}^N t^{4j+4N} \right]. \quad (5.35)$$

Note that for $N = n = 1$, we have $\mathbb{C}^2/\mathbb{Z}_4$, as expected from the Coulomb branch of $USp(2)$ with 3 flavors.

There is another way to check that theory (5.28) for $n = 1$ (and a general N) is self-mirror. We can easily compute a mirror theory of (5.31), with $n = 1$, by applying S -duality to the brane system; see (5.39). The result is

$$(5.36)$$

The Coulomb branch of this theory is isomorphic to that of 3d $\mathcal{N} = 4$ $SO(2N + 1)$ gauge theory with $2N$ flavors, whose Hilbert series is given in [30, (5.18)]. However, as pointed out in that reference, this turns out to be isomorphic to the Coulomb branch of the $USp(2N)$ gauge theory with $2N + 1$ flavors, whose Hilbert series is given by (5.35). We thus establish the self-duality of (5.28) for $n = 1$.

Theory (5.29)

The Higgs branch dimension of (5.29) is

$$\begin{aligned} \dim_{\mathbb{H}} \mathcal{H}_{(5.29)} &= (2)(2N^2) + (2n - 2)N(2N + 1) + \left[\frac{1}{2}(2N)(2N - 1) - N \right] \\ &\quad + N + N - n \left[\frac{1}{2}(2N)(2N + 1) \right] - 2 \left[\frac{1}{2}(2N)(2N - 1) \right] \\ &\quad - (n - 1) \left[\frac{1}{2}(2N + 1)(2N) \right] \\ &= N . \end{aligned} \tag{5.37}$$

The Coulomb branch dimension of (5.29) is equal to the total rank of the gauge groups that are not connected by $T[SO(2N)]$:

$$\dim_{\mathbb{H}} \mathcal{C}_{(5.29)} = (2n - 1)N . \tag{5.38}$$

These agree with the dimensions of the Coulomb and the Higgs branches of (5.28).

Similarly to the previous discussion, the red circular nodes that are connected by $T[SO(2N)]$ can be taken as $O(2N)$ or $SO(2N)$ without affecting the Higgs branch moduli space of (5.29). Moreover, we find that this applies to other red circular nodes in the quiver, namely the choice between $O(2N + 1)$ and $SO(2N + 1)$ does not change the Higgs branch of the theory. This can be checked directly using the Hilbert series.

It is worth pointing out that there is another gauge theory that gives the same Coulomb branch as (5.28). This is the mirror theory of (5.31) which is

given by

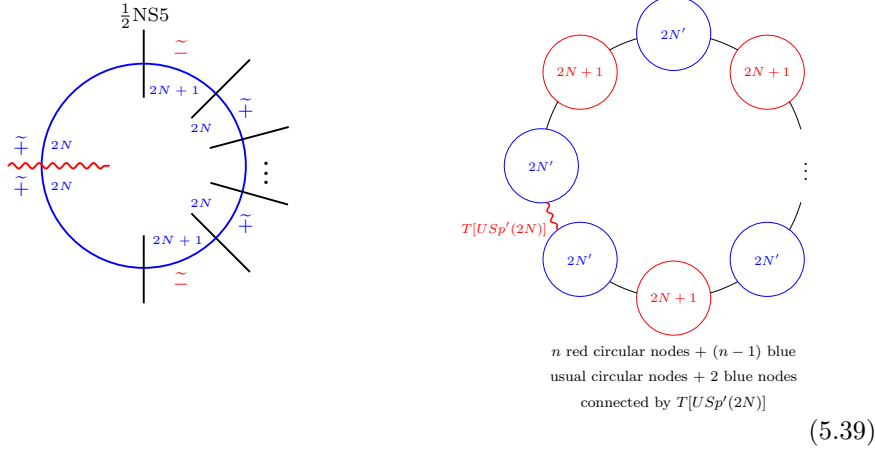

where the number of half-NS5 branes is $2n$. We expect that the Coulomb branch of (5.39) has to be equal to the Coulomb branch of (5.29). This can be seen as follows. Let us focus on (5.39). Note that the two blue circular nodes that are connected by $T[USp'(2N)]$ do not contribute to the Coulomb branch computation, so we can take them to be two flavor nodes that are not connected. As pointed out below [30, (5.18)], the Coulomb branch of the $SO(2N + 1)$ gauge theory with $2N$ flavors is the same as that of Coulomb branch of the $USp(2N)$ gauge theory with $2N + 1$ flavors. We can apply this fact to every node in quiver (5.39) and see that the resulting quiver has the same Coulomb branch as that of (5.29).

5.3 S-fold models with orientifold fiveplanes

In this subsection, we insert an S -fold into a brane interval of the aforementioned configurations. In general, the resulting quiver theory contains a $T[U(N)]$ link connecting two gauge nodes corresponding to the interval where we put the S -fold. The mirror configuration can simply be obtained by inserting the S -fold in the same position in the S -dual brane configuration. In the following, the moduli spaces of such a theory and its mirror are analyzed in detail.

We make the following important observation. The Higgs (*resp.* Coulomb) branch of a given theory gets exchanged with the Coulomb (*resp.* Higgs) branch of the mirror theory in a “regular way”, provided that

1. the S -fold is not inserted “too close” to the orientifold plane; and
2. the S -fold is not inserted in the “quiver tail”, arising from a set of D3 branes connecting a D5 brane with distinct NS5 branes.

Subsequently, we shall give more precise statements for these two points using various examples. In other words, we use mirror symmetry as a tool to indicate the consistency of the insertion of an S -fold to the brane system with an orientifold fiveplane.

5.3.1 Models with one or two antisymmetric hypermultiplets

In this subsection, we focus on the models with one antisymmetric hypermultiplet for definiteness. The case for two antisymmetric hypermultiplets can be treated almost in the same way. Let us insert an S -fold in a model with an $O5^-$ plane, an NS5 brane and $n_1 + n_2$ D5 branes in between. The S -fold is inserted in such a way there are n_1 physical D5 branes on the left of the S -fold and there are n_2 physical D5 branes on the right. The resulting theory is

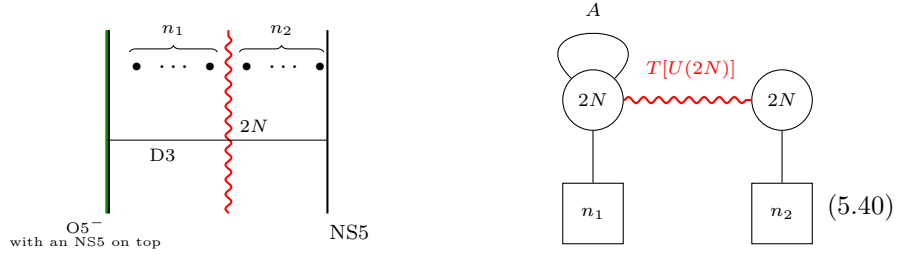

Let us observe that in absence of a second $O5^-$ plane at the end of the interval this model is not actually circular but it must be considered as a linear model. In the following, it is useful to think the S -folding procedure directly at the quiver level. S -folding a quiver consists in choosing a node and split it into two new pair of nodes coupled by a T-link. In doing this, we need also to chose how to distribute possible flavors between the two nodes. For instance, the model (5.40) can be thought as the S -folding of the following model:

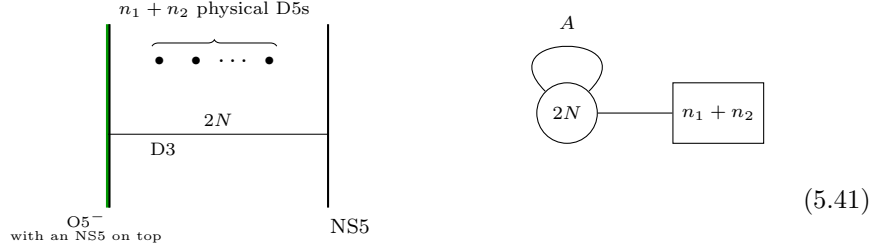

Mirrors of the models (5.40) can be obtained as the various possible S -foldings of the mirror theory of (5.41), whose brane description is

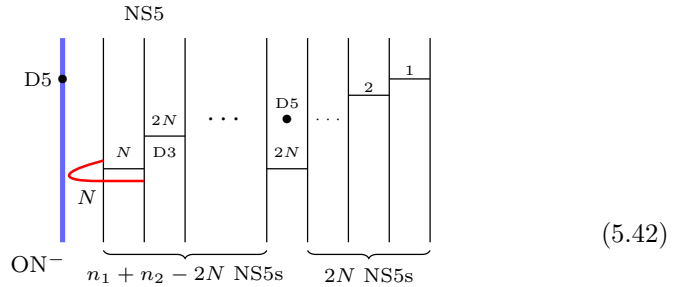

and the associated quiver is the following:

(5.43)

The case in which $n_1 \geq 2$ and $n_2 \geq 2N$

The mirror theory of (5.40) is

(5.44)

The condition $n_1 \geq 2$, $n_2 \geq 2N$ ensures that the $T[U(2N)]$ link in the mirror theory (5.44) stay between the first $U(2N)$ gauge node and the $U(2N)$ gauge node with 1 flavor.

The Higgs branch of theory (5.40) has dimension

$$\begin{aligned} \dim_{\mathbb{H}} \mathcal{H}_{(5.40)} &= 2Nn_1 + \frac{1}{2}2N(2N-1) + 2 \cdot \frac{1}{2}(4N^2 - 2N) + 2Nn_2 \\ &\quad - 4N^2 - 4N^2 \\ &= N(2n_1 + 2n_2 - 2N - 3), \end{aligned} \tag{5.45}$$

while the Coulomb branch is empty because there are only two gauge nodes connected by a $T[U(2N)]$ -link

$$\dim_{\mathbb{H}} \mathcal{C}_{(5.40)} = 0. \tag{5.46}$$

Since the moduli space of $T[U(2N)]$ contains the Higgs and Coulomb branches, each of which is isomorphic to the nilpotent cone of $SU(2N)$, it follows that the Higgs branch of (5.40) also splits into a product of two hyperkähler spaces which can be written in the notation of section A.2 as

(5.47)

The symmetry of $\mathcal{H}_{(5.40)}$ is $U(n_1) \times (U(n_2)/U(1))$, coming from the first and second factors respectively. According to (A.13) and below, the hyperkähler

space corresponding to the second factor is identified with $\overline{\mathcal{O}}_{(2N+1, 1^{n_2-2N-1})}$ for $n_2 \geq 2N+1$ and $\overline{\mathcal{O}}_{(2N)}$ for $n_2 = 2N$.

The mirror theory (5.44) has the following Coulomb branch dimension

$$\begin{aligned} \dim_{\mathbb{H}} \mathcal{C}_{(5.44)} &= N + N + (2N)(n_1 + n_2 - 2N - 2) + \sum_{i=1}^{2N-1} i \\ &= N(2n_1 + 2n_2 - 2N - 3), \end{aligned} \quad (5.48)$$

while the Higgs branch has dimension

$$\begin{aligned} \dim_{\mathbb{H}} \mathcal{H}_{(5.44)} &= N + 4N^2 + 4N^2(n_1 + n_2 - 2N - 1 - 1) + (4N^2 - 2N) \\ &\quad + 2N + \sum_{i=1}^{2N-1} i(i+1) - 2N^2 - 4N^2(n_1 + n_2 - 2N) \\ &\quad - \sum_{i=1}^{2N-1} i^2 = 0 \end{aligned} \quad (5.49)$$

Indeed, we find an agreement for the dimensions of the Higgs and Coulomb branches under mirror symmetry, namely

$$\dim_{\mathbb{H}} \mathcal{C}_{(5.40)} = \dim_{\mathbb{H}} \mathcal{H}_{(5.44)}, \quad \dim_{\mathbb{H}} \mathcal{C}_{(5.44)} = \dim_{\mathbb{H}} \mathcal{H}_{(5.40)}. \quad (5.50)$$

It should be pointed out that the Coulomb branch of (5.44) is also a product of two hyperkähler spaces. The reason is that the nodes that are connected by the $T[U(2N)]$ link do not contribute to the Coulomb branch and hence can be taken as flavor nodes. Therefore, the Coulomb branch of (5.44) is the product of the Coulomb branches of the following theories:

$$(5.51)$$

Under mirror symmetry, each of the factor in the product (5.47) is mapped to the Coulomb branch of each of the above quiver. Let us examine the symmetry of the Coulomb branch using the technique of [15]. In the left quiver, all balanced gauge nodes form a Dynkin diagram of A_{n_1-1} ; together with the top left node which is overbalanced, these give rise to the global symmetry algebra $A_{n_1-1} \times u(1)$, corresponding to $U(n_1)$. In the right quiver, all gauge nodes are balanced; these give rise to the symmetry algebra A_{n_2-1} , corresponding to $U(n_2)/U(1)$. This is in agreement of the symmetry of the Higgs branch $\mathcal{H}_{(5.40)}$.

It is worth commenting on the distribution of the flavors in theory (5.40). It is clear from the computation of the dimension of the Higgs branch (5.45) that one can change n_1 and n_2 keeping their sum $n = n_1 + n_2$ constant, without changing the dimension of the Higgs branch. However, as can be clearly seen from (5.47), the structure of the Higgs branch depends on n_1 and n_2 . In addition, modifying the distribution of the flavor will change the position of the $T[U(2N)]$

link in the mirror theory (5.44). Let us focus the case of $N = 1$ with $n_1 = 3$, $n_2 = 3$ and $n_1 = 4$, $n_2 = 2$. The theories and their mirrors are respectively

(5.52)

(5.53)

As explained in (5.47), the Higgs branch of the left diagram in each case splits into a product of two hyperkähler spaces. According to (A.14), the second factor in each line is the Hilbert series for the closure of the nilpotent orbit $\overline{\mathcal{O}}_{(3)}$ and $\overline{\mathcal{O}}_{(2)}$, coincident with the Higgs branch of the theories $T[SU(3)]$ and $T[SU(2)]$ respectively. The unrefined Hilbert series for the first factor is

$$\oint_{|z|=1} \frac{dz}{2\pi iz} (1-z^2) \oint_{|q|=1} \frac{dq}{2\pi iq} \text{PE} \left[n_1(z+z^{-1})(q+q^{-1}) \right. \\ \left. + (q^2+q^{-2})t + (z^2+1+z^{-2})t^2 - t^4 - (z^2+1+z^{-2}+1)t^2 \right] \\ \times \text{PE} \left[(z^2+1+z^{-2})t^2 - t^4 \right]. \quad (5.54)$$

We therefore arrive at the following results:

$$H[\mathcal{H}_{(5.40)}^{n_1=3, n_2=3}] = \text{PE} [9t^2 + 6t^3 - t^4 - 6t^5 - 10t^6 + \dots] \text{PE} [8t^2 - t^4 - t^6], \\ H[\mathcal{H}_{(5.40)}^{n_1=4, n_2=2}] = \text{PE} [16t^2 + 12t^3 - t^4 - 32t^5 - 54t^6 + \dots] \text{PE} [3t^2 - t^4], \quad (5.55)$$

These indicate that the symmetry of the Higgs branch is $U(n_1) \times (U(n_2)/U(1))$.

Of course, the above Hilbert series can also be obtained from the Coulomb branch of the corresponding mirror theory. As an example, as stated in (5.51), for $n_1 = 4$, $n_2 = 2$, the Coulomb branch of the right quiver of (5.53) is a product of the Coulomb branches of the following theories:

(5.56)

The Coulomb branch Hilbert series of the left quiver can be computed using the monopole formula proposed in [30] and that we review in appendix A.1:

$$\begin{aligned} & \sum_{a_1 \geq a_2 > -\infty} \sum_{m \in \mathbb{Z}} \sum_{n \in \mathbb{Z}} t^{2\Delta(\mathbf{a}, m, n)} P_{U(2)}(t, \mathbf{a}) P_{U(1)}(t, m) P_{U(1)}(t, n) \\ & = \text{PE} [16t^2 + 20t^3 - 12t^5 - 32t^6 + \dots], \end{aligned} \quad (5.57)$$

with $\mathbf{a} = (a_1, a_2)$,

$$\begin{aligned} \Delta(\mathbf{a}, m, n) & = \Delta_{U(2)-U(1)}(\mathbf{a}, m) + \Delta_{U(2)-U(1)}(\mathbf{a}, n) + \Delta_{U(2)-U(2)}(\mathbf{a}, 0) \\ & \quad + \Delta_{U(1)-U(1)}(m, 0) - \Delta_{U(2)}^{\text{vec}}(\mathbf{a}) \end{aligned} \quad (5.58)$$

and all of the other notations are defined in (A.5). This is indeed equal to the first factor in the first line of (5.55). The right quiver in (5.56) is the $T[SU(3)]$ theory whose Coulomb and Higgs branch Hilbert series is equal to the second factor in the first line of (5.55).

Issues regarding S -folding the quiver tail

Let us consider the case in which $n_2 < 2N$. The mirror theory of (5.40) is depicted in (5.59); the T -link appears on right of the $U(2N)$ node that is attached with one flavor. Let us suppose that the T -link connects two $U(n_2)$ gauge nodes where $1 \leq n_2 \leq 2N - 1$.

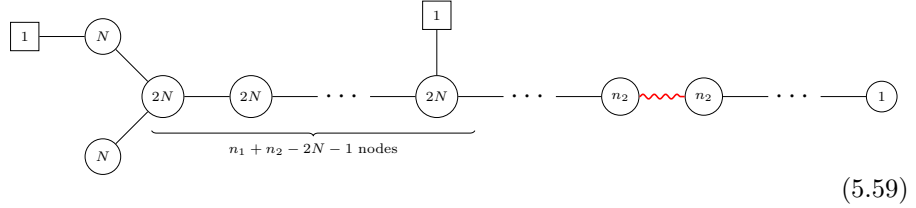

The Higgs branch dimension of such theory is

$$\dim_{\mathbb{H}} \mathcal{H}_{(5.59)} = \dim_{\mathbb{H}} \mathcal{H}_{(5.43)} + (n_2^2 - n_2) - n_2^2 = 2N - n_2. \quad (5.60)$$

Observe that this is non-zero for $1 \leq n_2 \leq 2N - 1$. However, as in (5.46), we have $\dim_{\mathbb{H}} \mathcal{C}_{(5.40)} = 0$ for any n_2 , since the two gauge nodes are connected by a T -link. Hence, this is inconsistent with mirror symmetry, based on our assumption that the gauge nodes connected by a T -link do not contribute to the Coulomb branch. One possible explanation of this inconsistency is that, in the presence of the S -fold, when move the D5 brane into the interval between NS5 branes, as depicted in picture (5.61) (equivalent to (5.42), after the appropriate Hanany-Witten moves):

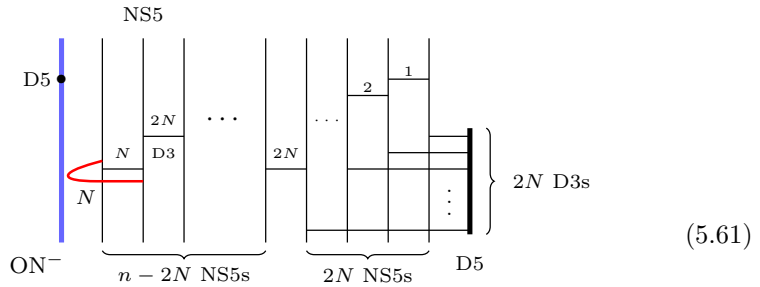

to the gauge group $USp(2N)$, and not $USp'(2N)$. We do not have the notion of a $T[USp(2N)]$ link since $USp(2N)$ is not invariant under the S -duality. This supports the point we made earlier that the S -fold cannot be inserted “too close” to the orientifold plane; it must be “shielded” by a sufficient numbers of fivebranes.

In order to obtain the mirror configuration, we can perform an S -folding of the mirror of (5.76), depicted in (5.79).

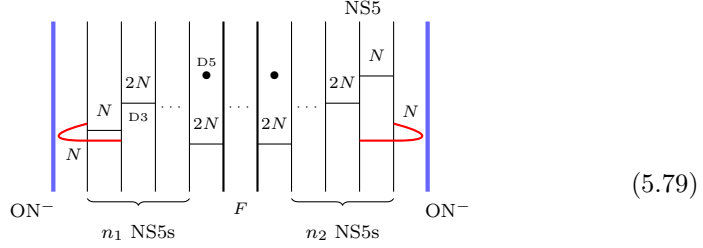

where the boldface vertical lines labelled by F denote a set of F NS5 branes, with $2N$ D3 branes stretching between two successive NS5 branes. The associated quiver is the following:

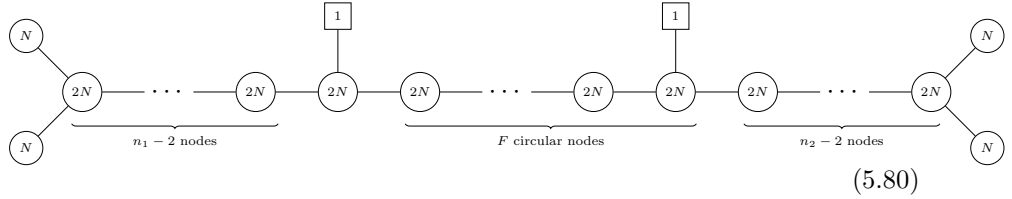

We can insert an S -fold anywhere between two D5-branes denoted by the black dots in (5.79). In terms of the quiver, this means that we can put the T -link anywhere in between the two $(2N)$ -nodes attached by one flavor. For example, for $N = 1$, $n_1 = n_2 = 3$, $F_1 = 1$ and $F_2 = 0$, the mirror theory is

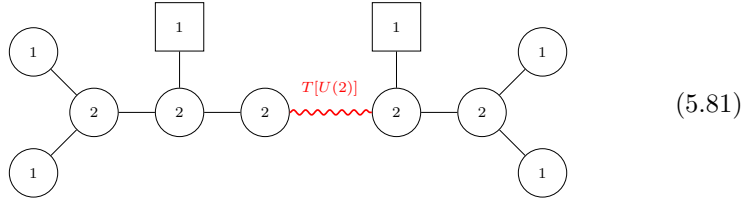

In order to compute the dimensions of Higgs and Coulomb branches of the mirror theory we can simply start with the corresponding non S -folded theory and observe that inserting a T -link implies the following:

- For the Higgs branch, we need to add the dimension of the $T[U(2N)]$ link, that in this case gives $4N^2 - 2N$ and subtract the gauging of the extra $U(2N)$, hence we subtract $4N^2$; in total we find that

$$\begin{aligned}
\dim_{\mathbb{H}} \mathcal{H}_{\text{mirr of (5.75)}} &= \dim_{\mathbb{H}} \mathcal{H}_{(5.80)} + (4N^2 - 2N) - 4N^2 \\
&= \dim_{\mathbb{H}} \mathcal{H}_{(5.80)} - 2N \\
&= (N + 2N + N) - 2N = 2N .
\end{aligned}
\tag{5.82}$$

- For the Coulomb branch, the result of inserting an S -fold is to add one gauge node and then consider that the ones connected by the T -link are frozen, so in total we have

$$\begin{aligned} \dim_{\mathbb{H}} \mathcal{C}_{\text{mirr of (5.75)}} &= \dim_{\mathbb{H}} \mathcal{C}_{(5.80)} - 2N \\ &= 2N(F_1 + F_2 + n_1 + n_2 - 2) , \text{ with } f_1 = F_1 + F_2 . \end{aligned} \quad (5.83)$$

These are in agreement with mirror symmetry.

In the above example of $N = 1$, $n_1 = n_2 = 3$, $f_1 = 1$ and $f_2 = 0$, one can compute the Hilbert series for (5.75) and its mirror (5.81). The unrefined results are

$$\begin{aligned} H[\mathcal{H}_{(5.75)}] &= H[\mathcal{C}_{(5.81)}] \\ &= \text{PE} [16t^2 + 12t^3 - 15t^4 - 40t^5 + 19t^6 + \dots] \times \\ &\quad \text{PE} [15t^2 - 16t^4 + 35t^6 + \dots] , \end{aligned} \quad (5.84)$$

and

$$\begin{aligned} H[\mathcal{C}_{(5.75)}] &= H[\mathcal{H}_{(5.81)}] \\ &= H[\mathcal{C}_{USp(2) \text{ with 5 flv}}]^2 = \text{PE} [t^4 + t^6 + t^8 + \dots]^2 . \end{aligned} \quad (5.85)$$

The above results deserve some explanations. In (5.81), the Coulomb branch symmetry can be seen from the after taking the two $U(2)$ gauge groups connected by the T -link to be two separate flavor symmetries. The left part gives an $SU(4) \times U(1)$ symmetry due to the fact that the balanced nodes form an A_3 Dynkin diagram and that there is one overbalanced node (namely, the $U(2)$ node that is attached to one flavor). The right part gives an $SU(4)$ symmetry due to the fact that the balanced nodes form an A_3 Dynkin diagram [15]. The Coulomb branch of (5.75) is identified with a product of two copies of the Coulomb branch of $USp(2)$ gauge theory with 5 flavors due to the following reason. The nodes connected by the T -link do not contribute to the Coulomb branch and therefore each of the left and the right parts contains the $USp(2)$ gauge theory with $2N + n_1 = 2 + 3 = 5$ flavors.

5.4 Models with the exceptional group G_2

5.4.1 Self-mirror models with a $T[G_2]$ link

In this section, we turn to models with a $T[G_2]$ link connecting between two G_2 gauge groups. We do not have the Type-IIB brane construction for such theories. Nevertheless, it is still possible to make some interesting statements

regarding the moduli space. We consider the following quiver:

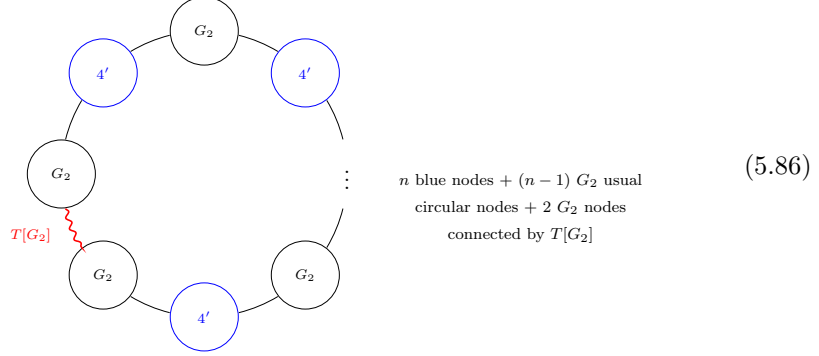

Note that every gauge group in the quiver has the same rank, in the same way as the preceding sections. The Higgs branch dimension of this quiver is

$$\dim_{\mathbb{H}} \mathcal{H}_{(5.86)} = (14 - 2) + \frac{1}{2}(2n)(4)(7) - 10n - 14(n - 1 + 2) = 2(2n - 1) . \quad (5.87)$$

On the other hand, the Coulomb branch dimension of this quiver is

$$\dim_{\mathbb{H}} \mathcal{C}_{(5.86)} = 2(2n - 1) . \quad (5.88)$$

Observe that the dimensions of the Higgs and Coulomb branches are equal. Indeed, we claim that quiver (5.86) is **self-mirror**. We shall consider some special cases and compute the Hilbert series to support this statement below.

In the absence of S -fold, the two G_2 gauge groups merge into a single gauge group and quiver (5.86) reduces to

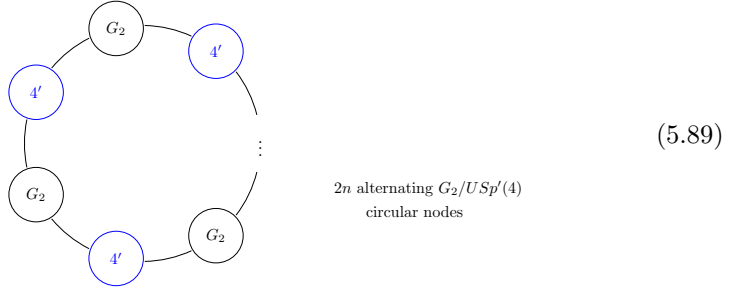

It can also be checked that the Higgs and Coulomb branch dimensions of this quiver are equal:

$$\dim_{\mathbb{H}} \mathcal{H}_{(5.89)} = \dim_{\mathbb{H}} \mathcal{C}_{(5.89)} = 4n . \quad (5.90)$$

Again, we claim that quiver (5.89) is also self-mirror. Indeed, one can check using the Hilbert series (say for $n = 1, 2$), in a similar way as that will be presented below, that the Higgs and Coulomb branches of (5.89) are equal.

Since we do not know the brane configurations for (5.86) and (5.89), we cannot definitely confirm if the gauge nodes labelled by 4 is really $USp(4)$ or $USp'(4)$. Nevertheless, we conjecture that such gauge nodes are $USp'(4)$, due to the fact that we can perform an “ S -folding” and obtain another quiver which is self-dual. The latter is depicted in (5.99) and will be discussed in detail in the next subsection.

The case of $n = 1$

In this case, (5.86) reduces to the following quiver:

$$(5.91)$$

The Higgs branch Hilbert series can be computed as

$$H[\mathcal{H}_{(5.91)}](t) = \int d\mu_{USp(4)}(\mathbf{z}) \{H[\mathcal{H}_{(A.39)}](t; \mathbf{z})\}^2 \text{PE} \left[-\chi_{[2,0]}^{G_2}(\mathbf{z})t^2 \right], \quad (5.92)$$

where $\mathbf{z} = (z_1, z_2)$ and $H[\mathcal{H}_{(A.39)}](t; \mathbf{z})$ is given by (A.43). The integration yields

$$H[\mathcal{H}_{(5.91)}](t) = \text{PE} [t^4 + t^6 + 2t^8 + t^{10} + t^{12} - t^{20} - t^{24}]. \quad (5.93)$$

This is the Coulomb branch Hilbert series of 3d $\mathcal{N} = 4$ $USp(4)$ gauge theory with 7 flavors [30, (5.14)]. On the other hand, since the vector multiplet of the G_2 gauge groups connected by $T[G_2]$ do not contribute to the Coulomb branch, the Coulomb branch of (5.91) is also isomorphic to the Coulomb branch of 3d $\mathcal{N} = 4$ $USp(4)$ gauge theory with 7 flavors.

We see that the Higgs and the Coulomb branches of (5.91) are equal to each other. We thus expect that theory (5.91) is self-mirror.

The case of $n = 2$

In this case, (5.86) reduces to the following quiver:

$$(5.94)$$

The Higgs branch Hilbert series can be computed similarly as before:

$$\begin{aligned} H[\mathcal{H}_{(5.94)}](t) = & \int d\mu_{USp(4)}(\mathbf{u}) \int d\mu_{USp(4)}(\mathbf{v}) \int d\mu_{G_2}(\mathbf{w}) \times \\ & H[\mathcal{H}_{(A.39)}](t; \mathbf{u}) H[\mathcal{H}_{(A.39)}](t; \mathbf{v}) \text{PE} \left[\chi_{[1,0]}^{G_2}(\mathbf{u}) \chi_{[1,0]}^{G_2}(\mathbf{w}) + \mathbf{u} \leftrightarrow \mathbf{v} \right] \\ & \text{PE} \left[-\chi_{[2,0]}^{G_2}(\mathbf{u})t^2 - \chi_{[2,0]}^{G_2}(\mathbf{v})t^2 - \chi_{[0,1]}^{G_2}(\mathbf{w})t^2 \right]. \end{aligned} \quad (5.95)$$

The Coulomb branch Hilbert series can be computed as if the two G_2 symmetries that are connected by $T[G_2]$ becomes two separated flavor nodes:

$$H[\mathcal{C}_{(5.94)}](t) = \sum_{n_1, n_2 \geq 0} \sum_{a_1 \geq a_2 \geq 0} \sum_{b_1 \geq b_2 \geq 0} t^{2\Delta(\mathbf{n}, \mathbf{a}, \mathbf{b})} P_{G_2}(t; \mathbf{n}) P_{C_2}(t; \mathbf{a}) P_{C_2}(t; \mathbf{b}) \quad (5.96)$$

where $\mathbf{n} = (n_1, n_2)$ are the fluxes of the G_2 gauge group, $\mathbf{a} = (a_1, a_2)$ and $\mathbf{b} = (b_1, b_2)$ are the fluxes for the two $USp(4)$ gauge groups. Here $\Delta(\mathbf{n}, \mathbf{a}, \mathbf{b})$ is the dimension of the monopole operator:

$$\begin{aligned} \Delta(\mathbf{n}, \mathbf{a}, \mathbf{b}) = & \Delta_{G_2-C_2}^{\text{hyp}}(\mathbf{0}, \mathbf{a}) + \Delta_{G_2-C_2}^{\text{hyp}}(\mathbf{0}, \mathbf{b}) + \Delta_{G_2-C_2}^{\text{hyp}}(\mathbf{n}, \mathbf{a}) + \Delta_{G_2-C_2}^{\text{hyp}}(\mathbf{n}, \mathbf{b}) \\ & - \Delta_{G_2}^{\text{vec}}(\mathbf{n}) - \Delta_{C_2}^{\text{vec}}(\mathbf{a}) - \Delta_{C_2}^{\text{vec}}(\mathbf{b}) \end{aligned} \quad (5.97)$$

where the various contributions to the monopole R-charge coming from bi-fundamental and adjoint hypermultiplets are summarized in (A.6). The dressing factors $P_{C_2}(t; \mathbf{a})$ and $P_{G_2}(t; \mathbf{n})$ are given by [30] and are collected in (A.4).

Upon calculating the integrals and the summations, we check up to order t^8 that the Higgs branch and the Coulomb branch Hilbert series are equal to each other:

$$H[\mathcal{H}_{(5.94)}](t) = H[\mathcal{C}_{(5.94)}](t) = \text{PE} [4t^4 + 5t^6 + 10t^8 + \dots] . \quad (5.98)$$

This again supports our claim that (5.94) is self-mirror.

Self-mirror models with a $T[USp'(4)]$ link

We can obtain another variation of (5.86) by simply S -folding one of the $USp'(4)$ gauge nodes in (5.89). The result is

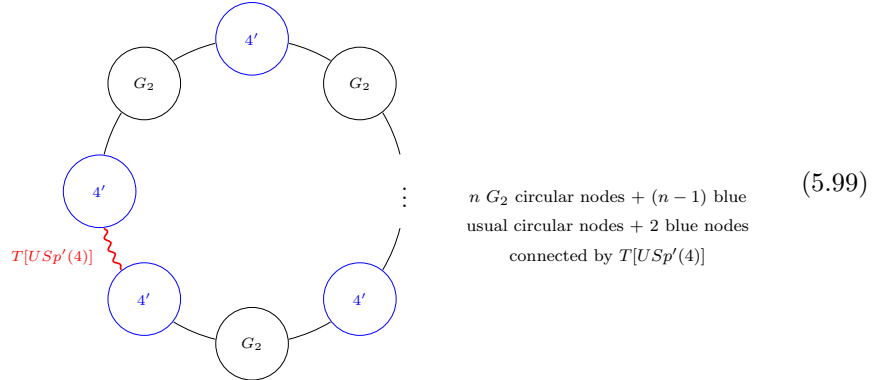

The dimension of the Higgs branch is indeed equal to that of the Coulomb branch:

$$\dim_{\mathbb{H}} \mathcal{H}_{(5.99)} = \dim_{\mathbb{H}} \mathcal{C}_{(5.99)} = 2(2n-1) . \quad (5.100)$$

We claim that (5.99) is also self-mirror for any $n \geq 1$. One can indeed check, for example in the cases of $n = 1, 2$, that the Higgs and the Coulomb branch Hilbert series are equal, in the same way as presented in the preceding subsection. As

an example, for $n = 1$, these are equal to the Coulomb branch Hilbert series of the G_2 gauge theory with 4 flavors [30, (5.28)]:

$$H[\mathcal{H}_{(5.99)}|_{n=1}] = H[\mathcal{C}_{(5.99)}|_{n=1}] = \text{PE} [2t^4 + t^6 + t^8 + t^{10} + 2t^{12} + \dots] . \quad (5.101)$$

We finally remark that since we can perform an “ S -folding” at any blue node, this confirms that each blue node labelled by 4 is indeed $USp'(4)$.

5.4.2 More mirror pairs by adding flavors

In this subsection, we add fundamental flavors to the self-mirror models discussed earlier and obtain mirror pairs that are not self-dual.

Let us start the discussion by adding n flavors to the $USp'(4)$ gauge group in (5.91). This yields

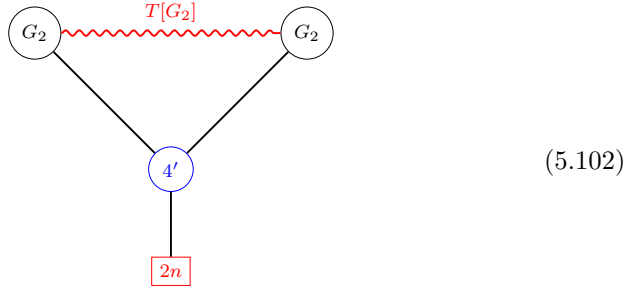

where the flavor symmetry is $SO(2n)$. The dimensions of the Higgs and Coulomb branches of this quiver are

$$\dim_{\mathbb{H}} \mathcal{H}_{(5.102)} = 4n + 2 , \quad \dim_{\mathbb{H}} \mathcal{C}_{(5.102)} = 2 . \quad (5.103)$$

We propose that (5.102) is mirror dual to

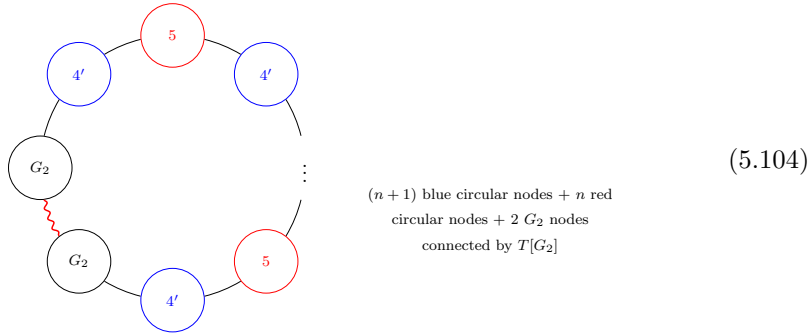

The Higgs branch dimension of this model is

$$\begin{aligned} \dim_{\mathbb{H}} \mathcal{H}_{(5.104)} &= (14 - 2) + 2 \left(\frac{1}{2} \times 7 \times 4 \right) + 10(2n) \\ &\quad - 14 - 14 - 10(n + 1) - 10n \\ &= 2 . \end{aligned} \quad (5.105)$$

and the Coulomb branch dimension of this is $\dim_{\mathbb{H}} \mathcal{C}_{(5.104)} = 2(2n + 1)$. This is consistent with mirror symmetry. We shall soon match the Higgs/Coulomb

branch Hilbert series of (5.102) with the Coulomb/Higgs branch Hilbert series of (5.104) for $n = 1$.

Although we do not have a brane construction for (5.104) due to the presence of the G_2 gauge groups, the part of the quiver that contains alternating $USp'(4)/SO(5)$ gauge groups could be “realized” by a series of brane segments involving alternating $\widetilde{O}3^+/\widetilde{O}3^-$ across NS5 branes. In other words, starting from (5.102), the mirror theory (5.104) can be obtained by making the following replacement:

(5.106)

In the absence of the S -fold, the two G_2 gauge groups that were connected by $T[G_2]$ merge into a single one. We thus obtain the mirror pair between the following elliptic models:

(5.107)

The case of $n = 1$

Let us first focus on (5.102). The Higgs branch Hilbert series can be computed simply by putting the term $\text{PE}[(x + x^{-1})\chi_{[1,0]}^{C_2}(\mathbf{z})t]$ in the integrand of (5.92), where x is the $SO(2)$ flavor fugacity. Performing the integral, we obtain (after setting $x = 1$):

$$H[\mathcal{H}_{(5.102)}|_{n=1}](t; x = 1) = 1 + t^2 + 9t^4 + 15t^6 + 60t^8 + 113t^{10} + \dots \quad (5.108)$$

The Coulomb branch Hilbert series for (5.102) is equal to that of the 3d $\mathcal{N} = 4$ $USp(4)$ gauge theory with $7 + 1 = 8$ flavors. The latter is given by

$$H[\mathcal{C}_{(5.102)}|_{n=1}](t) = \text{PE}[t^4 + 2t^8 + t^{10} + t^{12} + t^{14} - t^{24} - t^{28}] \quad (5.109)$$

Let us now turn to (5.104). The Higgs branch Hilbert series is given by (5.95) with the following replacement:

$$\int d\mu_{G_2}(\mathbf{w}) \rightarrow \int d\mu_{SO(5)}(\mathbf{w}), \quad \chi_{[1,0]}^{G_2}(\mathbf{w}) \rightarrow \chi_{[1,0]}^{B_2}(\mathbf{w}), \quad \chi_{[0,1]}^{G_2}(\mathbf{w}) \rightarrow \chi_{[0,2]}^{B_2}(\mathbf{w}). \quad (5.110)$$

We checked that the result of this agrees with (5.109) up to order t^{10} . The Coulomb branch Hilbert series of (5.104) can be obtained in a similar way from (5.96) with the following replacement:

$$\begin{aligned} \Delta_{G_2}^{\text{vec}}(\mathbf{n}) &\rightarrow \Delta_{B_2}^{\text{vec}}(\mathbf{n}) = |n_1| + |n_2| + |n_1 + n_2| + |n_1 - n_2| \\ \Delta_{G_2-C_2}^{\text{hyp}}(\mathbf{n}, \mathbf{a} \text{ or } \mathbf{b}) &\rightarrow \Delta_{B_2-C_2}^{\text{hyp}}(\mathbf{n}, \mathbf{a} \text{ or } \mathbf{b}) \\ P_{G_2}(t; \mathbf{n}) &\rightarrow P_{C_2}(t; \mathbf{n}) \end{aligned} \quad (5.111)$$

with

$$\Delta_{B_2-C_2}^{\text{hyp}}(\mathbf{n}, \mathbf{a}) = \frac{1}{2} \times \frac{1}{2} \sum_{s_1, s_2=0}^1 \sum_{j=1}^2 \left[|(-1)^{s_2} a_j| + \sum_{i=1}^2 |(-1)^{s_1} n_i + (-1)^{s_2} a_j| \right]. \quad (5.112)$$

Again, we checked that the result of this agrees with (5.108) up to order t^{10} .

Generalisation of (5.102) to a polygon with flavors added

We can generalize (5.102) to a polygon consisting of alternating $G_2/USp'(4)$ gauge groups, with n flavors added to one of the $USp'(4)$ gauge group. This is depicted below.

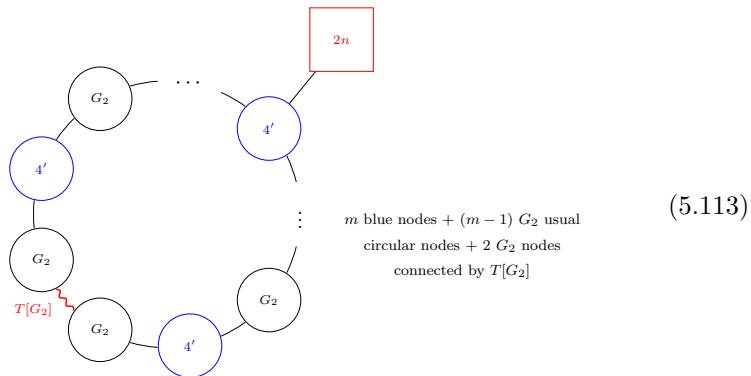

The mirror theory can simply be obtained by applying the replacement rule (5.106). For example, we have the following mirror pair

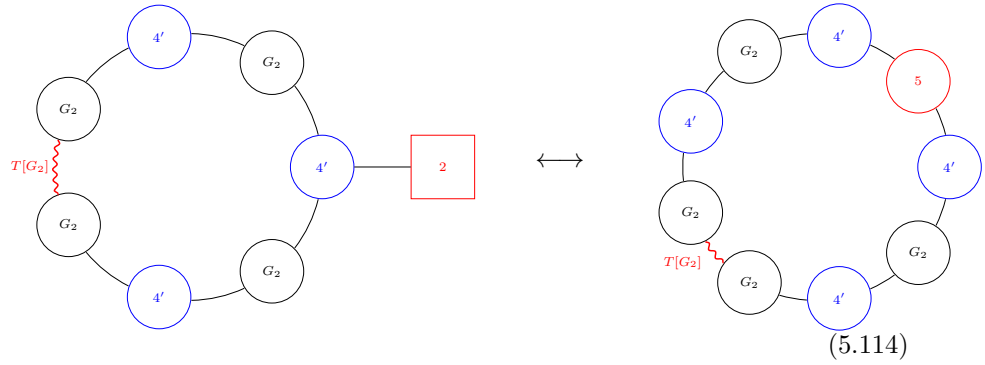

As emphasized before, as a by-product, one may obtain a mirror pair between the usual field theories, without an S -fold, by simply merging the two G_2 nodes that are connected by $T[G_2]$. The replacement rule described in (5.106) still applies. As an example, (5.114) becomes

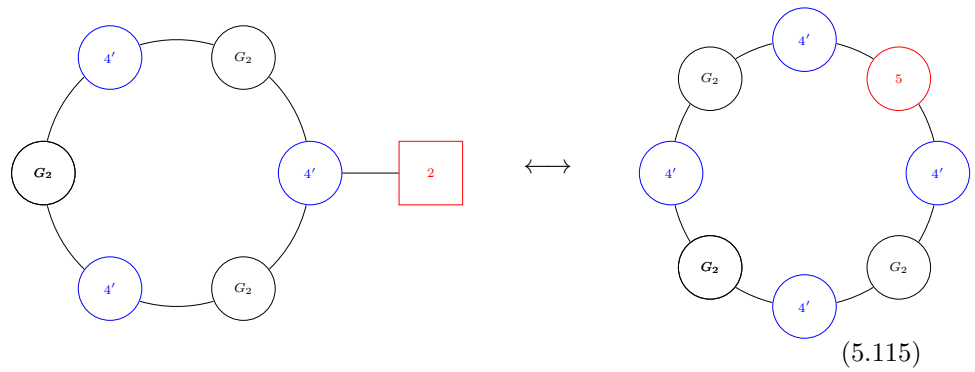

Chapter 6

Supersymmetric index of S-fold SCFTs

In the previous chapters we studied the moduli space of S-fold CFTs. The main tool that we used is mirror symmetry a duality between 3d $\mathcal{N} = 3$ or $\mathcal{N} = 4$ theories exchanging Higgs and Coulomb branch. The difference between the two cases with different supersymmetry consists in the structure of the whole moduli space. In the $\mathcal{N} = 4$ case, the moduli space contains two main branches: the Higgs branch parametrized by the VEVs of hypermultiplets (in particular of the mesons and baryons) and the Coulomb branch, parametrized by the VEVs of the vector multiplet scalars (in particular the monopoles). In the $\mathcal{N} = 3$ case, the moduli space can be more complicated. We can recognize the Higgs branch to be parametrized again by mesons (and possibly baryons) but this time Coulomb branch is parametrized not only by monopoles but also by mesons at the same time. Together with the Coulomb branch, other smaller branches are parametrized by both monopoles and mesons and they are usually called mixed branch. Determining all the mixed branches can be particularly complicated and we often focused on the two maximal cones only. However, this difference is not strong enough to infer something about the infrared supersymmetry of a theory. In fact, it can happens that monopoles and mesons conspire in order to cause a supersymmetry enhancement at low energies [77].

As we observed in chapter 3, one could naively think that S-fold CFTs possess $\mathcal{N} = 3$ supersymmetry, due to the gauging of Higgs and Coulomb global symmetry at the same time. The supergravity dual, proposed in [19] and reviewed in section 3.3, gives insight about the actual supersymmetry of the model. S-flip models are dual to supergravity backgrounds with $SO(3)$ isometries acting on the supercharges; this suggest that, at least at large N , such models still have $\mathcal{N} = 3$ supersymmetry at the fixed point. In contrast, J-fold models (where Chern-Simons levels are explicitly tuned on) are dual to backgrounds with full $SO(4)$ isometries, so that we expect the theories to have enhanced $\mathcal{N} = 4$ supersymmetry at the fixed point. We want to stress that curiously the models enjoying enhancement are the ones with Chern-Simons terms.

The supersymmetry suggested by supergravity arguments is reliable only at large N . For finite N it is not clear which is the infrared number of preserved supercharges. Moreover, the study performed for J -fold theories in [19] only

focused on J-fold configurations with no 5-branes at all, so that it is not clear if supersymmetry still gets enhanced when matter is taken into account, even in the large N limit. The one of purposes of this section is to investigate this problem from the quantum field theory side. The main tool that we have at disposal in this case is the supersymmetric index (SSI). The index is nothing but the supersymmetric partition function on $S^2 \times S^1$ with periodic boundary condition for the fields along S^1 and counts the number of BPS operators. It turns out that it is an RG flow invariant, so that it can be also computed in the UV in order to get insight about the IR fixed point. Whenever the theory admit a superconformal point, it is also referred as superconformal index (SCI) and counts the BPS short multiplets up to recombination. As we will see, signals of supersymmetry (or global symmetry) enhancement can be found in the index. In the following, we compute the SCI for various S-fold theories, trying to address the problem of the actual number of preserved supercharges at the fixed point.

Another interesting phenomenon that we can investigate using superconformal index is the following. Let us consider a given S-fold configuration: as pointed out in [19], we can always think to take a D5 brane and make it pass through the wall. In this case, we need to perform the appropriate (local) $SL(2, \mathbb{Z})$ transformation on the brane; in both S and J_k cases the D5 brane becomes an NS5 and we got an equivalent configuration. In this way, it is possible to generate a chain of S-fold theories with different quiver realizations but actually dual. We test such dualities with the superconformal index, taking track of how operators are mapped under the local duality transformation.

Let us anticipate that in the following we will specify if the choice made of J-fold corresponds to an hyperbolic, elliptic or parabolic configuration, following the nomenclature already introduced in section 4.5. This is particularly important to compare the results with the previous ones suggested by the large N study of [19], where only the hyperbolic cases have been taken into account.

6.1 Superconformal multiplets and the index

The supersymmetric index is defined as the partition function on $S^2 \times S^1$ and can be computed as a trace over states:

$$\mathcal{I}(x, \boldsymbol{\mu}) = \text{Tr} \left[(-1)^{2J_3} x^{\Delta + J_3} \prod_i \mu_i^{T_i} \right], \quad (6.1)$$

where Δ is the energy in units of the S^2 radius (for superconformal field theories, Δ is related to the conformal dimension), J_3 is the Cartan generator of the Lorentz $SO(3)$ isometry of S^2 , and T_i are charges under non- R global symmetries. The index only receives contributions from the states that satisfy:

$$\Delta - R - J_3 = 0, \quad (6.2)$$

where R is the R -charge. As a partition function on $S^2 \times S^1$, localization implies that the index receives contributions only from BPS configurations, and it can be written in the following compact way:

$$\mathcal{I}(x; \{\boldsymbol{\mu}, \boldsymbol{n}\}) = \sum_m \frac{1}{|\mathcal{W}_m|} \int \frac{dz}{2\pi iz} Z_{\text{cl}} Z_{\text{vec}} Z_{\text{mat}}, \quad (6.3)$$

where we denoted by \mathbf{z} the fugacities parameterising the maximal torus of the gauge group, and by \mathbf{m} the corresponding GNO magnetic fluxes on S^2 . Here $|\mathcal{W}_{\mathbf{m}}|$ is the dimension of the Weyl group of the residual gauge symmetry in the monopole background labelled by the configuration of magnetic fluxes \mathbf{m} . We also use $\{\boldsymbol{\mu}, \mathbf{n}\}$ to denote possible fugacities and fluxes for the background vector multiplets associated with global symmetries, respectively. The precise expression of the various contributions to the index in (6.3) are reviewed in appendix B. In the following we will focus on superconformal theories so that it is better to refer to the index as superconformal. It can be expanded as power series in x , the fugacity for the combination of energy and angular momentum, $\Delta + J_3$ that equals $R + 2J_3$ in the BPS case:

$$\mathcal{I}(x, \{\boldsymbol{\mu}, \mathbf{n} = 0\}) = \sum_{p=0}^{\infty} \chi_p(\boldsymbol{\mu}) x^p, \quad (6.4)$$

where we preferred to put background magnetic fluxes to zero. Recall that short multiplets are counted up to recombination, so that one may classify the equivalence classes of the multiplets according to their contribution to the index.¹ Since the shortening conditions for 3d superconformal algebras have been classified [81, 82]², we already know which superconformal multiplets can actually enter the SCI and one can extract a lot of useful information about the SCFT under investigation studying in the appropriate way the power series expansion of the index (6.4). We adopt this approach to study enhancement of supersymmetry and possibly other global symmetries in the context of 3d S -fold SCFTs.³ A generic operator \mathcal{O} can be labeled by its relevant quantum numbers, *i.e.* the spin J_3 under Lorentz transformations, the energy (or equivalently scaling dimension) Δ and the Dynkin label of the representation of $SO(\mathcal{N})$ R-symmetry if the theory possesses \mathcal{N} supersymmetry. In the $\mathcal{N} = 2$ case, each operator such that $\Delta - J_3 - R$ enters the index at level $x^{\Delta+J_3}$. As pointed out in [85], it is useful to define the modified index as follows:

$$\tilde{\mathcal{I}}(x, \{\boldsymbol{\mu}, \mathbf{n} = 0\}) = (1 - x^2) [\mathcal{I}(x, \{\boldsymbol{\mu}, \mathbf{n} = 0\}) - 1]. \quad (6.5)$$

Note that all of the terms up to order x^2 in the modified index $\tilde{\mathcal{I}}$ are equal to those in the original index \mathcal{I} with the same power. At a given a level x^p of the modified index, only specific operators can enter. Each operator sits in some short multiplet and $\mathcal{N} = 2$ supermultiplets that can non-trivially contribute to the modified index at order x^p for $p \leq 2$ are as follows [80]:

Multiplet	Contribution to the modified index	Comment
$A_2 \bar{B}_1 [0]_{1/2}^{(1/2)}$	$+x^{1/2}$	free fields
$B_1 \bar{A}_2 [0]_{1/2}^{(-1/2)}$	$-x^{3/2}$	free fields
$L \bar{B}_1 [0]_1^{(1)}$	$+x$	relevant operators
$L \bar{B}_1 [0]_2^{(2)}$	$+x^2$	marginal operators
$A_2 \bar{A}_2 [0]_1^{(0)}$	$-x^2$	conserved currents

(6.6)

¹See [78, 79] for a detailed discussion about the index of 4d SCFTs, and [80] for 3d SCFTs.

²Here we follow the notation of [82].

³This approach has proved successful, in the context of 3d $\mathcal{N} = 2$ gauge theories, for the study of global symmetry enhancement (see *e.g.* [27, 80, 83, 84]) and supersymmetry enhancement (see *e.g.* [85, 86]).

We denote with:

$$\mathcal{O}[j]_{\Delta}^{(r)} \tag{6.7}$$

a superconformal primary operator \mathcal{O} with spin $J_3 = j$, scaling dimension Δ and R-charge r . For instance $A_2\bar{B}_1$ is nothing but a free chiral field while $B_1\bar{A}_2$ is an anti-chiral field. The names of the operators in the first column of table (6.6) are conventional [82]. Observe that the coefficient of x^2 in the index counts the number of marginal operators minus the number of conserved currents. Let us stress again that the multiplets are counted up to recombination only: this means that it can sometimes happen that a marginal operator (in the adjoint representation of the gauge group) exactly cancel with conserved currents and we cannot detect them in any way.

6.2 A single $U(N)_k$ gauge group with a T -link and n flavors

In this section, we consider the following theory:

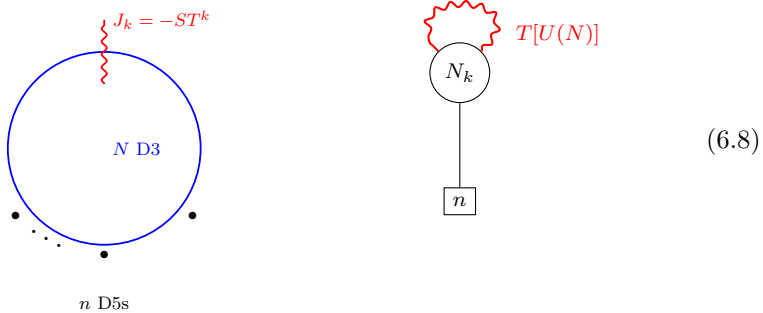

In [19], the following statements are proposed:

1. For $k = 0$, the SCFT has $\mathcal{N} = 3$ supersymmetry.
2. For $k \geq 3$ and $n = 0$, the SCFT has $\mathcal{N} = 4$ supersymmetry. This statement was confirmed at large N using the corresponding supergravity solutions and the computation of the three sphere partition function in the large N limit.

In the following we compute the superconformal index at low rank N and small values of n . Whenever possible, we deduce the amount of supersymmetry of the SCFT from the index.

6.2.1 The abelian case: $N = 1$

The moduli space of this theory was analyzed in [29]. Recall that the $T[U(1)]$ is almost an empty theory, with only a prescription for how coupling external gauge fields A_1 and A_2 , which is the supersymmetric completion of the following CS coupling [15]

$$-\frac{1}{2\pi} \int A_1 \wedge dA_2 . \tag{6.9}$$

In (6.8), we identify the $U(1)$ gauge fields A_1 and A_2 to a single one, and hence the above equation gives rise to a CS level -2 to the $U(1)$ gauge group. In other words, quiver (6.8), with $N = 1$, can be identify with the following theory

$$\begin{array}{c} \textcircled{1_{k-2}} \text{---} \square_n \end{array} \quad (6.10)$$

where we emphasize that this theory no longer contains a T -link.

As an immediate consequence, for $k = 2$, this theory is simply a 3d $\mathcal{N} = 4$ $U(1)$ gauge theory with n flavors. For $k = 2$ and $n = 1$, this is dual to a theory of a free hypermultiplet.

Another interesting case is when $k = 1$ and $n = 1$, which is equivalent to having 3d $\mathcal{N} = 3$ $U(1)_{-1}$ gauge theory with 1 flavor. The index in this case reads

$$\begin{aligned} \mathcal{I}_{(6.8), N=1, k=1, n=1}(x; \omega) &= \mathcal{I}_{U(1)_{\pm 1} \text{ with 1 flavor}}(x; \omega) \\ &= 1 + x - x^2 (\omega + \omega^{-1} + 1) + x^3 (\omega + \omega^{-1} + 2) \\ &\quad - x^4 (\omega + \omega^{-1} + 2) + x^5 + \dots \end{aligned} \quad (6.11)$$

where ω denotes the topological fugacity. The modified index of this theory is

$$(1 - x^2) [\mathcal{I}_{(6.8), N=1, k=-1}(x; \omega) - 1] = x - x^2 (\omega + \omega^{-1} + 1) + \dots \quad (6.12)$$

We expect the enhancement of supersymmetry from $\mathcal{N} = 3$ to $\mathcal{N} = 5$ due to the following argument.⁴ The presence of the term $+x$ indicates that there must be an $\mathcal{N} = 3$ flavor current multiplet $B_1[0]_1^{(2)}$, which gives rise to the $\mathcal{N} = 2$ multiplet $L\bar{B}_1[0]_1^{(1)}$ contributing $+x$ and the $\mathcal{N} = 2$ multiplet $A_2\bar{A}_2[0]_1^{(0)}$ contributing $-x^2$. Since the coefficient of x^2 counts the number of marginal operators minus the number of conserved currents [80, 84] (see also [79]), there must be two extra conserved currents associated with the terms $-(\omega + \omega^{-1})x^2$. Such extra conserved currents come from two $\mathcal{N} = 3$ extra SUSY-current multiplets $A_2[0]_1^{(0)}$, one carries fugacity ω and the other carries fugacity ω^{-1} .

6.2.2 $U(2)_k$ gauge group and no flavor

We focus on the following quiver

$$\begin{array}{c} \textcircled{2_k} \text{---} \text{ } T[U(2)] \end{array} \quad (6.13)$$

We remark that the theory (6.13) can be also be represented as $T[U(2)]/U(2)_k^{\text{diag}}$, where the diagonal subgroup $U(2)^{\text{diag}}$ of the symmetry $U(2) \times U(2)$ of $T[U(2)]$

⁴Upon setting $\omega = 1$, we obtain the unrefined modified index $x - 3x^2 + 3x^3 - x^4 - 3x^5 + \dots$. Denoting the coefficient of x^k by a_k , we see that $(-a_2) = 3 > a_1 = 1$. Therefore according to [85, sec. 4.3], it is expected that supersymmetry gets enhanced from $\mathcal{N} = 3$ to $\mathcal{N} = 3 - a_1 - a_2 = 5$. Moreover, since $a_1 = 1$, $a_2 = -3 \geq -3$ and $a_p = 0$ (which is even) for all non-integers p , the necessary condition in [85, sec. 4.3] for having $\mathcal{N} = 5$ supersymmetry is satisfied.

is gauged with CS level k . Nevertheless, we find that the index of such a theory does not depend on the fugacity associated with the topological symmetry, and it is equal to $T[SU(2)]SU(2)/SU(2)_k^{\text{diag}}$, where the diagonal subgroup $SU(2)^{\text{diag}}$ is gauged with CS level k .

In fact, the theory $T[SU(2)]/SU(2)_k^{\text{diag}}$ was studied in a series of papers [25–27, 86], mainly in the context of the 3d-3d correspondence. In particular, it was pointed out in [86] that for $k = 3$, $T[SU(2)]/SU(2)_3^{\text{diag}}$ is a product of two identical 3d $\mathcal{N} = 4$ SCFTs. Such an SCFT admits a 3d $\mathcal{N} = 2$ Lagrangian in terms of the $U(1)_{-3/2}$ gauge theory with 1 chiral multiplet carrying gauge charge +1 (denoted by $\mathcal{T}_{-3/2,1}$), where it turns out that supersymmetry of this theory gets enhanced to $\mathcal{N} = 4$ in the infrared.

In addition to the case of $|k| = 3$, we find that the supersymmetry gets enhanced for all k such that $|k| \geq 4$. We summarize the results in the following table.

CS level	Index	Type of J_k	Comment
$ k \geq 4$	(6.14)	hyperbolic	Studied in [86], a product of two $\mathcal{N} = 4$ SCFTs
$ k = 3$	(6.17)	hyperbolic	
$ k = 2$	diverges	parabolic	
$ k = 1$	1	elliptic	
$k = 0$	1	elliptic	

We emphasize the cases whose indices indicate supersymmetry enhancement in yellow. In the following, we discuss the detail of each case.

For $|k| \geq 4$, J_k is hyperbolic. We find that the index reads

$$\mathcal{I}_{(6.13), N=2, |k| \geq 4}(x) = 1 - x^2 + 2x^3 - x^4 + \dots \quad (6.14)$$

where, for each k such that $|k| \geq 4$, the indices differ at order of x greater than 4. For example, up to order x^8 , the indices are as follows:

$$\begin{aligned} |k| = 4 & \quad 1 - x^2 + 2x^3 - x^4 - 4x^5 + 10x^6 - 10x^7 + 8x^8 + \dots \\ |k| = 5 & \quad 1 - x^2 + 2x^3 - x^4 - 2x^5 + 6x^6 - 8x^7 + 4x^8 + \dots \\ |k| = 6 & \quad 1 - x^2 + 2x^3 - x^4 - 2x^5 + 6x^6 - 8x^7 + 6x^8 + \dots \end{aligned} \quad (6.15)$$

The modified index is

$$(1 - x^2) [\mathcal{I}_{(6.13), N=2, |k| \geq 4}(x) - 1] = -x^2 + 2x^3 + \dots \quad (6.16)$$

The fact that the coefficient of x vanishes implies that we have no $\mathcal{N} = 3$ flavor current multiplet $B_1[0]_1^{(2)}$.

The term $-x^2$ indicates the presence of the $\mathcal{N} = 3$ extra SUSY-current multiplet $A_2[0]_1^{(0)}$. We thus conclude that the supersymmetry gets enhanced from $\mathcal{N} = 3$ to $\mathcal{N} = 4$ when $|k| \geq 4$.

For $|k| = 3$, the index reads

$$\mathcal{I}_{(6.13), N=2, |k|=3}(x) = 1 - 2x^2 + 4x^3 - 3x^4 + \dots \quad (6.17)$$

According to [86], this is equal to the square of the index of $\mathcal{T}_{-3/2,1}$. In the notation that we adopt, the index of $\mathcal{T}_{-3/2,1}$ reads

$$\mathcal{I}_{\mathcal{T}_{-3/2,1}}(x; w) = 1 - x^2 + (w + w^{-1})x^3 - 2x^4 + \dots \quad (6.18)$$

where w is the topological fugacity. Indeed, we find that

$$[\mathcal{I}_{\mathcal{T}_{-3/2,1}}(x; w = 1)]^2 = \mathcal{I}_{(6.13), N=2, k=-3}(x). \quad (6.19)$$

The modified index corresponding to (6.17) reads

$$(1 - x^2) [\mathcal{I}_{(6.13), N=2, |k|=3}(x) - 1] = -2x^2 + 4x^3 - x^4 \dots \quad (6.20)$$

Let us denote the coefficient of x^p by a_p . Naively, from the condition $-a_2 = 2 > a_1 = 0$ discussed in [85], one might expect that supersymmetry gets enhanced to $\mathcal{N} = 3 - a_1 - a_2 = 5$. However, this cannot be true, for the reason that the $\mathcal{N} = 5$ stress tensor multiplet in the representation $[1, 0]$ of $SO(5)$ decomposes into one $\mathcal{N} = 2$ multiplet $L\bar{B}_1[0]_1^{(1)}$, which contributes $a_1 = 1$ [85, (B.25)] (but here we have $a_1 = 0$). Since this theory is a product of two copies of $\mathcal{T}_{-3/2,1}$, which has enhanced $\mathcal{N} = 4$ supersymmetry, there are two copies of the $\mathcal{N} = 3$ extra SUSY-current multiplet $A_2[0]_{\Delta=1}^{(0)}$. This is consistent with the fact that the modified index has $a_1 = 0$ and $a_2 = -2$.

For the theory with $|k| = 2$ (J_2 is parabolic), the index diverges, and so we have a “bad” theory in the sense of [15]. For $|k| = 1$ and $k = 0$ (J_k is elliptic in these cases), we find that the index is equal to unity.

6.2.3 Adding one flavor ($n = 1$) to the $U(2)_k$ gauge group

We now consider the following theory



$$(6.21)$$

Let us summarize the results in the following table.

CS level	Index	Type of J_k	Comment
$k = -2$	(6.30)	parabolic	
$k = -1$	(6.29)	elliptic	
$k = 0$	(6.29)	elliptic	
$k = 1$	(6.22)	elliptic	
$k = 2$	(6.24)	parabolic	A free hyper \times an $\mathcal{N} = 4$ SCFT
$ k \geq 3$	(6.29)	hyperbolic	

where we emphasize the cases that have supersymmetry enhancement in yellow.

For $k = 1$, we find that the index reads

$$\begin{aligned} \mathcal{I}_{(6.21), k=1}(x; \omega) &= 1 + x + x^2 [1 - (1 + \omega + \omega^{-1})] - x^3 (\omega + \omega^{-1}) \\ &\quad + x^4 (4 + \omega^2 + \omega^{-2} + 3\omega + 3\omega^{-1}) + \dots, \end{aligned} \quad (6.22)$$

where ω is the topological fugacity. From the above expression, we find that the modified index is as follows:

$$(1 - x^2) [\mathcal{I}_{(6.21), k=1}(x; \omega) - 1] = x + x^2 [1 - (1 + \omega + \omega^{-1})] + \dots \quad (6.23)$$

From this, one can see the enhancement of supersymmetry from $\mathcal{N} = 3$ to $\mathcal{N} = 5$ as follows. The presence of the term $+x$ indicates that there must be an

$\mathcal{N} = 3$ flavor current multiplet $B_1[0]_1^{(2)}$, which gives rise to the $\mathcal{N} = 2$ multiplet $L\bar{B}_1[0]_1^{(1)}$ contributing $+x$ and the $\mathcal{N} = 2$ multiplet $A_2\bar{A}_2[0]_1^{(0)}$ contributing $-x^2$. Since the coefficient of x^2 counts the number of marginal operators minus the number of conserved currents [80, 84] (see also [79]), there must be an $\mathcal{N} = 2$ marginal operator (in the multiplet $L\bar{B}_1[0]_2^{(2)}$) contributing $+x^2$ to cancel the aforementioned contribution $-x^2$, and there must be two extra conserved currents associated with the terms $-(\omega + \omega^{-1})x^2$. The latter can only come from two copies of the $\mathcal{N} = 3$ extra SUSY-current multiplet $A_2[0]_1^{(0)}$, carrying the global symmetry associated with ω and ω^{-1} . (This gives rise to two copies of $\mathcal{N} = 2$ $A_2\bar{A}_2[0]_1^{(0)}$ multiplet contributing the term $-(\omega + \omega^{-1})x^2$.) The presence of such a multiplet leads to the enhancement of supersymmetry from $\mathcal{N} = 3$ to $\mathcal{N} = 5$.⁵

For $k = 2$, the index reads

$$\begin{aligned} \mathcal{I}_{(6.21), k=2}(x; w) &= 1 + \left(w + \frac{1}{w}\right) x^{\frac{1}{2}} + \left(2w^2 + \frac{2}{w^2} + 2\right) x + \left(2w^3 + \frac{2}{w^3} + 2w + \frac{2}{w}\right) x^{\frac{3}{2}} \\ &\quad + \left(3w^4 + \frac{3}{w^4} + 2w^2 + \frac{2}{w^2} + 1\right) x^2 + \dots \end{aligned} \tag{6.24}$$

The term $x^{1/2}$ indicates that this theory contains a free part due to the fact that the R -charge of the basic monopole operators hits the unitary bound. The above index can be rewritten as

$$\mathcal{I}_{(6.21), k=2}(x; w) = \mathcal{I}_{\text{free}}(x; w) \times \mathcal{I}_{\text{SCFT}}^{(6.21), k=2}(x; w) \tag{6.25}$$

where the index of a free hypermultiplet is given by

$$\mathcal{I}_{\text{free}}(x; w) = \frac{(x^{2-\frac{1}{2}}w; x^2)_{\infty} (x^{2-\frac{1}{2}}w^{-1}; x^2)_{\infty}}{(x^{\frac{1}{2}}w^{-1}; x^2)_{\infty} (x^{\frac{1}{2}}w; x^2)_{\infty}} \tag{6.26}$$

and the index of the interacting SCFT part is

$$\begin{aligned} \mathcal{I}_{\text{SCFT}}^{(6.21), k=2}(x; w) &= 1 + x \left(w^2 + \frac{1}{w^2} + 1\right) + x^2 \left(w^4 + \frac{1}{w^4} - 1\right) + x^{5/2} \left(-w - \frac{1}{w}\right) + \dots \\ &= 1 + x\chi_{[2]}^{SU(2)}(w) + x^2 \left[\chi_{[4]}^{SU(2)}(w) - (\chi_{[2]}^{SU(2)}(w) + \chi_{[0]}^{SU(2)}(w))\right] \\ &\quad - x^{\frac{5}{2}}\chi_{[2]}^{SU(2)}(w) + \dots, \end{aligned} \tag{6.27}$$

⁵We remark that one has to use the sufficient condition stated in [85] with great care. Upon setting $\omega = 1$ in the modified index, we obtain $x - 2x^2$. Denoting the coefficient of x^k by a_k , we see that $-a_2 = 2 > a_1 = 1$, and from [85], one might naively expect that supersymmetry gets enhanced to $\mathcal{N} = 3 - a_1 - a_2 = 4$, because we have only $(-a_2) - a_1 = 1$ extra SUSY-current multiplet. The unrefinement of the index is misleading here, because we in fact have two extra SUSY-current multiplets carrying the global fugacities ω and ω^{-1} , and these cannot be cancelled with -1 at order x^2 in the index. The reason for us to write $x^2 [1 - (1 + \omega + \omega^{-1})]$ is to show explicitly that the contribution -1 of the conserved current has to be cancelled with the contribution $+1$ from the marginal operator, which is neutral under the symmetry associated with ω . Note that since $a_1 = 1$, $a_2 = -2 \geq -3$ and $a_p = 0$ (which is even) for all non-integers p , the necessary condition in [85] for having $\mathcal{N} = 5$ supersymmetry is satisfied.

with the unrefinement

$$\mathcal{I}_{\text{SCFT}}^{(6.21), k=2}(x; w=1) = 1 + 3x + x^2 - 2x^{5/2} + 4x^3 + 4x^{7/2} + 3x^4 + \dots \quad (6.28)$$

As can be seen from (6.27), the interacting SCFT has enhanced $\mathcal{N} = 4$ supersymmetry. The argument is similar to the one used before. The term $+x\chi_{[2]}^{SU(2)}(w)$ indicates that the theory has an $SU(2)$ flavor symmetry. Indeed, there is an $\mathcal{N} = 3$ flavor current multiplet $B_1[0]_1^{(2)}$ transforming in the adjoint representation [2] of this symmetry; this gives rise to the $\mathcal{N} = 2$ multiplet $L\bar{B}_1[0]_1^{(1)}$ contributing $+x\chi_{[2]}^{SU(2)}(w)$ and the $\mathcal{N} = 2$ multiplet $A_2\bar{A}_2[0]_1^{(0)}$ contributing $-x^2\chi_{[2]}^{SU(2)}(w)$. The term $+x^2\chi_{[4]}^{SU(2)}(w)$ corresponds to the $\mathcal{N} = 2$ marginal operator⁶ in the multiplet $L\bar{B}_1[0]_2^{(2)}$. It can be clearly seen that there is another conserved current corresponding to the term $-x^2\chi_{[0]}^{SU(2)}(w)$. Indeed, the latter comes from the $\mathcal{N} = 3$ extra SUSY-current multiplet $A_2[0]_1^{(0)}$ in the trivial representation [0] of $SU(2)$; this gives rise to an $\mathcal{N} = 2$ conserved current multiplet $A_2\bar{A}_2[0]_1^{(0)}$ contributing the term $-x^2\chi_{[0]}^{SU(2)}(w)$. The existence of the extra SUSY-current multiplet indicates that there is an enhancement of supersymmetry from $\mathcal{N} = 3$ to $\mathcal{N} = 4$.

For $k = 0, -1$ and $|k| \geq 3$, we find that the index reads

$$1 + x + 0x^2 + \dots \quad (6.29)$$

The term $+x$ indicates that there must be an $\mathcal{N} = 3$ flavor current multiplet $B_1[0]_1^{(2)}$, which gives rise to the $\mathcal{N} = 2$ multiplet $L\bar{B}_1[0]_1^{(1)}$ contributing $+x$ and the $\mathcal{N} = 2$ multiplet $A_2\bar{A}_2[0]_1^{(0)}$ contributing $-x^2$. Hence the theory has a $U(1)$ flavor symmetry. The fact that the term x^2 vanishes implies that there is an $\mathcal{N} = 2$ marginal operator in the multiplet $L\bar{B}_1[0]_2^{(2)}$, contributing $+x^2$, which cancels the aforementioned $-x^2$ term. Hence, in this case, there is no signal of the existence of the extra SUSY-current multiplet, *i.e.* we cannot deduce the enhancement of supersymmetry.

For $k = -2$, we find that the index reads

$$1 + 2x + x^2 + 8x^4 + \dots \quad (6.30)$$

There are two $\mathcal{N} = 3$ flavor current multiplet $B_1[0]_1^{(2)}$ which gives rise to two copies of $\mathcal{N} = 2$ multiplets $L\bar{B}_1[0]_1^{(1)}$ contributing $+2x$ and two copies of $\mathcal{N} = 2$ multiplets $A_2\bar{A}_2[0]_1^{(0)}$ contributing $-2x^2$. Hence the theory has a $U(1)^2$ flavor symmetry. We may construct three $\mathcal{N} = 2$ marginal operators by taking a symmetric product of two relevant operators in the $L\bar{B}_1[0]_1^{(1)}$ multiplets. Their contribution $+3x^2$ cancels the aforementioned $-2x^2$ and yields $+x^2$. There is no signal of the existence of the extra SUSY-current multiplet, *i.e.* we cannot deduce the enhancement of supersymmetry.

⁶It should be noted that the 2nd symmetric power of [2] is $\text{Sym}^2[2] = [4] + [0]$. The representation [4], appearing at order x^2 of the index, is a part of this symmetric power.

6.2.4 Adding n flavors to the $U(2)_2$ gauge group

In this section, we add an arbitrary number of flavors to the parabolic case⁷, namely



$$(6.31)$$

When the number of flavors is one (*i.e.* $n = 1$), we have seen from (6.25) that the theory factorizes into a product of the theory of a free hypermultiplet and an interacting SCFT with enhanced $\mathcal{N} = 4$ supersymmetry. For $n \geq 2$, the index does not exhibit explicitly the presence of the extra SUSY-current multiplet. Nevertheless, as we demonstrate below, the theory still has interesting physics that bears a certain resemblance to the 3d $\mathcal{N} = 4$ $U(1)$ gauge theory with n flavors, such as the properties of monopole operators.

For concreteness, let us first consider the case of $n = 2$. The index reads⁸

$$\begin{aligned} \mathcal{I}_{(6.31), n=2}(x; \omega, y) &= 1 + x \left[\chi_{[2]}^{SU(2)}(\omega) + \chi_{[2]}^{SU(2)}(y) \right] + x^2 \left[\left(1 + 2\chi_{[4]}^{SU(2)}(\omega) + \chi_{[4]}^{SU(2)}(y) \right. \right. \\ &\quad \left. \left. + \chi_{[2]}^{SU(2)}(\omega)\chi_{[2]}^{SU(2)}(y) + \chi_{[2]}^{SU(2)}(y) \right) - \left(\chi_{[2]}^{SU(2)}(\omega) + \chi_{[2]}^{SU(2)}(y) \right) \right] + \dots, \end{aligned} \quad (6.32)$$

with the unrefinement

$$\mathcal{I}_{(6.31), n=2}(x; \omega = 1, y = 1) = 1 + 6x + 22x^2 + 18x^3 + 29x^4 + \dots \quad (6.33)$$

where the topological fugacity is denoted by $w = \omega^2$. We see that the $U(1)$ topological symmetry gets enhanced to $SU(2)$. This phenomenon also occurs for 3d $\mathcal{N} = 4$ $U(1)$ gauge theory with 2 flavors, whose index is

$$\begin{aligned} \mathcal{I}_{T[SU(2)]}(x; \omega, y) &= 1 + x \left[\chi_{[2]}^{SU(2)}(\omega) + \chi_{[2]}^{SU(2)}(y) \right] \\ &\quad + x^2 \left[\chi_{[4]}^{SU(2)}(\omega) + \chi_{[4]}^{SU(2)}(y) - \left(\chi_{[2]}^{SU(2)}(\omega) + \chi_{[2]}^{SU(2)}(y) + 1 \right) \right] + \dots \end{aligned} \quad (6.34)$$

with the unrefinement

$$\mathcal{I}_{T[SU(2)]}(x; \omega = 1, y = 1) = 1 + 6x + 3x^2 + 6x^3 + 17x^4 + \dots, \quad (6.35)$$

⁷Here $J_2 = -ST^2$ is a parabolic element of $SL(2, \mathbb{Z})$. It is related to T^{-1} by the following similarity transformation: $(TST)J_2(TST)^{-1} = T^{-1}$. However, we emphasise that, when fundamental flavors are added as in (6.31), the theory is different from $U(2)_{-1}$ with n flavors. This can be seen clearly from the indices. For example, for $n = 1$, the index for $U(2)_{-1}$ with 1 flavor is 1 but (6.25) is non-trivial.

⁸The symmetric product of the representation $[2; 0] + [0; 2]$ of $SU(2) \times SU(2)$ is $2[0; 0] + [4; 0] + [0; 4] + [2; 2]$. The representation in the first bracket of order x^2 (*i.e.* those with plus signs) can be written as $\text{Sym}^2([2; 0] + [0; 2]) + [4; 0] + [0; 2] - [0; 0]$. In the same way as in footnote 6, one singlet in the decomposition of the symmetric power does not participate in the index; this explains the term $-[0; 0]$. Moreover, it is worth pointing out that, in this case, there are extra representations that are not contained in the symmetric product, namely $[4; 0]$ and $[0; 2]$.

Let us take, for example, $N = 2$, $k = 2$ and $n = 3$. The index of the left quiver is given by (6.36). The index of the right quiver reads

$$\begin{aligned}
& 1 + x \left[2 + (w_1 + w_1^{-1})\chi_{[1]}^{SU(2)}(\tilde{y}) + \chi_{[2]}^{SU(2)}(\tilde{y}) \right] + x^{\frac{3}{2}} \left(w_1 w_2 + \frac{1}{w_1 w_2} \right) \\
& + x^2 \left[4 + (w_1^2 + 3 + w_1^{-2})\chi_{[2]}^{SU(2)}(\tilde{y}) + (w_1 + w_1^{-1}) \left(\chi_{[3]}^{SU(2)}(\tilde{y}) + 2\chi_{[1]}^{SU(2)}(\tilde{y}) \right) \right. \\
& \left. + \chi_{[4]}^{SU(2)}(\tilde{y}) \right] + \dots .
\end{aligned} \tag{6.41}$$

where w_1 and w_2 are the topological fugacities associated with the left and right nodes, and we denote the $SU(2)$ flavor fugacities by \tilde{y} . This expression can be rewritten in the way that the $SU(3)$ symmetry is manifest by setting

$$w_1 = y_1^{-\frac{3}{2}} , \quad \tilde{y} = y_1^{-\frac{1}{2}} y_2 , \tag{6.42}$$

upon which we recover the expression (6.36).

From the coefficient of x , we see that the mesons in the adjoint representation $[1, 1]$ of $SU(3)$ of the left quiver in (6.40) are mapped to the following operators of the right quiver in (6.40):

1. the mesons in the adjoint representation $[2]$ of the $SU(2)$ flavor symmetry;
2. the dressed monopole operators in the fundamental representation $[1]$ of $SU(2)$ and carrying topological charges ± 1 under the left node¹⁰; and
3. the trace of the adjoint chiral field associated with the left node.

Moreover, by comparing the terms at order $x^{\frac{3}{2}}$ in (6.36) and (6.41), we see that the basic monopole operators V_{\pm} , carrying topological charges ± 1 , in the left quivers are mapped to the basic monopole operators $V_{\pm(1,1)}$, carrying topological charges $\pm(1, 1)$, in the right quivers.

These statements can be easily generalized to other values of k and n . Observe that we can in principle test the duality with other theories. Starting from 6.40, we can move another D5 brane across the J -fold in the brane configuration of the right quiver. In this way, we generate a new dual theory with the following quiver description:

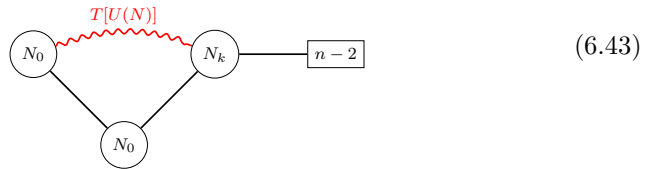

This time, only $U(n-2)$ flavor symmetry is manifest. As before, such symmetry will combine with the topological symmetries of the gauge nodes in order to restore the full $U(n)$. However, this requires a complicated dynamics involving mesons and monopoles, analogously to what discussed for the duality in (6.40).

¹⁰This is similar to the dressed monopole operators (4.163) in the abelian theory.

We can keep moving D5-branes across the wall. When all the D5-branes are moved, we end up with the following quiver:

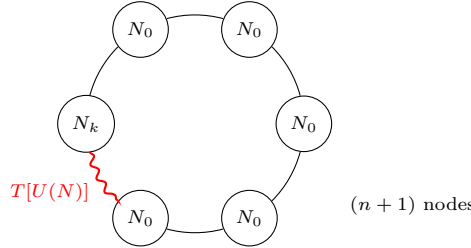

$$(6.44)$$

For $k = 0$, this would be exactly the mirror symmetry theory of the quiver on the left in (6.40). In fact, we can observe that the symmetry group $U(n)$ is not realized at all as flavor symmetry but it emerges from the topological symmetries.

6.4 $U(2)_{k_1} \times U(2)_{k_2}$ with two T -links

In this subsection we consider the following theory

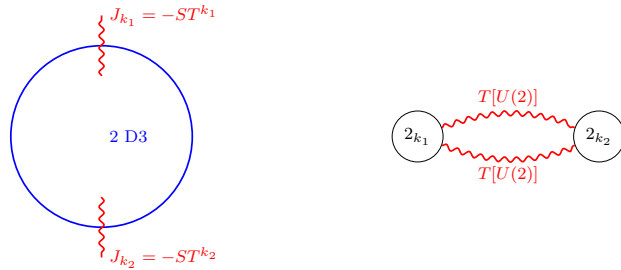

$$(6.45)$$

The three sphere partition function as well as the supergravity solution corresponding to $U(N)_{k_1} \times U(N)_{k_2}$ gauge group (*i.e.* N D3 branes), in the large N limit, were studied in [19]. In such a reference, the CS levels were restricted such that $\text{tr}(\pm J_{k_1} J_{k_2}) > 2$, equivalently $\pm(k_1 k_2 - 2) > 2$, where the sign \pm is chosen such that the trace is greater than 2. In which case, $J_{k_1} J_{k_2}$ is a hyperbolic element of $SL(2, \mathbb{Z})$, and the theory was predicted to have $\mathcal{N} = 4$ supersymmetry in the large N limit. Here, instead, we focus on the superconformal indices and supersymmetry enhancement when the gauge group is taken to be $U(2)_{k_1} \times U(2)_{k_2}$ for general values of k_1 and k_2 .

Note that if one of k_1 or k_2 is 1, say $k_1 = 1$, we have $J_1 J_{k_2} = STST^{k_2}$. This is related by a T -similarity transformation to $TJ_1 J_{k_2} T^{-1} = T(STST^{k_2-1})T^{-1} = -ST^{k_2-2} = J_{k_2-2}$, where we have used the identity $TSTST = -S$ (see also [19]). In other words, the two duality walls J_1 and J_{k_2} can be reduced to a single duality wall J_{k_2-2} (assuming that there are no NS5 and D5 branes). Henceforth, we shall not consider such a possibility in the absence of hypermultiplet matter.

In general, we observe that whenever $J_{k_1} J_{k_2}$ is a *parabolic* element of $SL(2, \mathbb{Z})$, *i.e.* $|\text{tr}(J_{k_1} J_{k_2})| = |k_1 k_2 - 2| = 2$ or equivalently $k_1 k_2 = 0$ or 4 , the index diverges and the theory is “bad” in the sense of [15]. In which case, we cannot deduce the low energy behavior of the theory from its quiver description.

We observe that the index of (6.45) does not depend on the fugacities associated with the topological symmetries. Similarly to section 6.2.2, the gauge group in (6.45) can be taken to be $SU(2)_{k_1} \times SU(2)_{k_2}$ and this yields the same index.

Let us now take $k_1 = 2$ and examine various values of k_2 as follows.

CS levels (k_1, k_2)	Index	Type of $J_{k_1} J_{k_2}$	Comment
(2, 5)	$1 + x^4 + \dots$	hyperbolic	
(2, 4)	$1 + x^4 + \dots$	hyperbolic	
(2, 3)	$1 - x^2 + 2x^3 - x^4 + \dots$	hyperbolic	New, SUSY enhancement
(2, 2)	diverges	parabolic	
(2, 1)	1	elliptic	Same as (6.13), $k = 0$
(2, 0)	diverges	parabolic	
(2, -1)	(6.14)	hyperbolic	Same as (6.13), $k = \pm 4$
(2, -2)	$1 + x^4 + \dots$	hyperbolic	
(2, -3)	$1 + x^4 + \dots$	hyperbolic	
(2, -4)	$1 + x^4 + \dots$	hyperbolic	

The cases whose indices exhibit supersymmetry enhancement are emphasized in yellow. The indices for the cases not highlighted in yellow do not signal the presence of extra SUSY-current multiplets. The CS levels $(k_1, k_2) = (2, 3)$ gives a new SCFT with enhanced $\mathcal{N} = 4$ supersymmetry, whereas the case with $(k_1, k_2) = (2, -1)$ is the same as theory (6.13) with $k = -4$, which also has supersymmetry enhancement to $\mathcal{N} = 4$.

For $k_1 = 3$, we find a similar pattern, as tabulated below. Unfortunately, the cases that has supersymmetry enhancement, namely $(k_1, k_2) = (3, 2)$ and $(3, -1)$, are identical with certain theories that have been discussed before.

CS levels (k_1, k_2)	Index	Type of $J_{k_1} J_{k_2}$	Comment
(3, 4)	$1 + x^4 + \dots$	hyperbolic	
(3, 3)	$1 + 2x^4 + \dots$	hyperbolic	
(3, 2)	$1 - x^2 + 2x^3 + \dots$	hyperbolic	Same as $(k_1, k_2) = (2, 3)$
(3, 1)	1	elliptic	Same as (6.13), $k = \pm 1$
(3, 0)	diverges	parabolic	
(3, -1)	(6.14)	hyperbolic	Same as (6.13), $k = \pm 5$
(3, -2)	$1 + x^4 + \dots$	hyperbolic	

6.4.1 Adding flavors to the parabolic case

In this section, we add fundamental flavors to either or both nodes in the parabolic case. For definiteness, we consider the theory involving two J_2 duality

walls¹¹ and a collection of D5 branes arranged in the following way:

(6.46)

and focus on the cases of $N = 1$ and $N = 2$. Such theories have interesting physical properties as we shall describe below.

Let us first discuss the abelian case. Since this theory admits a conventional Lagrangian description, we can easily analyze this theory along the lines of [29]. The detailed analysis is provided in section 4.5. We find that whenever fundamental hypermultiplets are added to the quiver associated with parabolic J -folds, an interesting branch of the moduli space arises, mainly due to the presence of the gauge neutral monopole (or dressed monopole) operators. In particular, for quiver (6.46) with $N = 1$, we find that there are two branches of the moduli space. One can be identified as the Higgs branch and the other can be identified as the Coulomb branch, both of which are hyperkähler cones. This feature is very similar to that of general 3d $\mathcal{N} = 4$ gauge theories. The Higgs branch is isomorphic to a product of the closures of the minimal nilpotent orbits $\overline{\mathcal{O}}_{\min}^{SU(n_1)} \times \overline{\mathcal{O}}_{\min}^{SU(n_2)}$, where each factor is generated by the mesons constructed using the chiral multiplets in each fundamental hypermultiplet; see (4.152). The Coulomb branch is isomorphic to $\mathbb{C}^2/\mathbb{Z}_{n_1+n_2}$, which is generated by the monopole operators $V_{\pm(1,1)}$ with fluxes $\pm(1,1)$ and the complex scalar in the vector multiplet; see (4.156). For a general n_1 and n_2 , this theory has a global symmetry $\left(\frac{U(n_1) \times U(n_2)}{U(1)}\right) \times U(1)$, where the former factor denotes the flavor symmetry coming from the fundamental hypermultiplets and latter $U(1)$ denotes the topological symmetry. For the special case of $n_1 + n_2 = 2$, the $U(1)$ topological symmetry gets enhanced to $SU(2)$, which is also an isometry of the Coulomb branch $\mathbb{C}^2/\mathbb{Z}_2$. Interestingly, if we set one of n_1 or n_2 to zero, say

(6.47)

This theory turns out to be the same as quiver (6.8) with $N = 1$, $k = 2$, which is identical to 3d $\mathcal{N} = 4$ $U(1)$ gauge theory with n flavors (*i.e.* the $T_{(n,n-1)}(SU(n))$ theory [15]). One can indeed check that the moduli spaces and the indices of the two theories are equal. Such an identification indicates that when $n_1 = 0$ (or $n_2 = 0$), the two J_2 duality walls can be “collapsed” into one, and the gauge node in (6.47) that is not flavored can be removed such that the T -link becomes a loop around the other gauge node. We remark that this statement only holds for the abelian case; we will see that for $N = 2$ this is no longer true.

¹¹Similarly to the remark in footnote 7, even though J_2^2 is related to T^{-2} by a similarity transformation in $SL(2, \mathbb{Z})$, upon adding hypermultiplet matter, the theory becomes non-trivial.

Quiver (6.46) with $N > 1$ still bears the same features as in the abelian ($N = 1$) theory. In general, the index of (6.46) contains the terms $x^{\frac{1}{2}(n_1+n_2)}(w_1 w_2 + w_1^{-1} w_2^{-1})$, which indicates that there are gauge invariant monopole operators $V_{\pm(1,0,\dots,0;1,0,\dots,0)}$, with fluxes $\pm(1, 0, \dots, 0)$ under each of the $U(N)$ gauge group, carrying R -charge $\frac{1}{2}(n_1 + n_2)$. Again, for $n_1 + n_2 = 2$, the $U(1)$ topological symmetry gets enhanced to $SU(2)$. Furthermore, when $n_1 + n_2 = 1$, *i.e.* $(n_1, n_2) = (1, 0)$ or $(0, 1)$, such monopole operators decouple as a free hypermultiplet (this is similar to the one flavor case discussed in section 6.2.3). Let us consider, in particular, the case of $N = 2$, $n_1 = 0$ and $n_2 = 1$:

(6.48)

Indeed the index can be written as

$$\mathcal{I}_{(6.48)} = \mathcal{I}_{\text{free}}(x; w) \times \mathcal{I}_{\text{SCFT}}^{(6.48)}(x; w) \quad (6.49)$$

where we define w as the product of the topological fugacities associated with the two gauge groups: $w = w_1 w_2$. The index of the free hypermultiplet $\mathcal{I}_{\text{free}}(x; w)$ is given by (6.26), and the index for the interacting SCFT is

$$\begin{aligned} \mathcal{I}_{\text{SCFT}}^{(6.48)}(x; w) = & 1 + x \chi_{[2]}^{SU(2)}(w) + x^2 \left[\chi_{[4]}^{SU(2)}(w) - \chi_{[2]}^{SU(2)}(w) \right] \\ & - x^{\frac{5}{2}} \chi_{[2]}^{SU(2)}(w) + \dots \end{aligned} \quad (6.50)$$

with the unrefinement

$$\mathcal{I}_{\text{SCFT}}^{(6.48)}(x; w = 1) = 1 + 3x + 2x^2 - 2x^{5/2} - 4x^3 + \dots \quad (6.51)$$

The interacting SCFT has a flavor symmetry $SU(2)$. Notice that the index of the SCFT (6.50) is different from (6.27). (Hence, we cannot collapse two J_2 duality walls into one as in the abelian case.) In particular, while (6.27) exhibits the presence of the extra-SUSY current multiplet, (6.50) does not.

Chapter 7

Conclusions and Perspectives

In this section we want to collect the main results of part II of the text and point out possible future directions and leftover open problems. The aim of the works presented in this thesis is studying S-fold SCFTs from various perspectives.

First we studied the moduli space of various theories, computing the associated Hilbert series in order to check the consistency with mirror symmetry of various proposed mirror pairs. In the case of S-flip SCFTs, where no Chern-Simons levels are turned on for T-linked gauge nodes, we propose that Higgs and Coulomb branches can be computed using standard techniques. The Higgs branch of a model can be computed as an hyperkähler quotient, as explained in details in chapter 4. Using mirror symmetry as a tool, we deduce that the T-linked gauged nodes are actually frozen and do not contribute to the Coulomb branch dynamics; we named this feature freezing rule. Let us stress that this proposal provides information about the behavior of D3-branes, whose position along the NS5 directions is stuck when intersecting an S-duality wall. We observed that more general $T[G]$ -links can be considered, with G being a self-Langlands compact Lie group. In the case of $G = SO(2N)$ and $G = USp'(2N)$ we proposed such S-fold theories to be dual to Hanany-Witten configuration with one S-flip and O3 or O5 orientifold planes. We computed the Hilbert series of various models and checked the consistency against mirror symmetry; in particular we checked that the conjectured freezing rule still holds and we observed new phenomena as the screening effect; it states that an S-flip cannot be inserted too close to an O5 plane, in a sense specified in the main text. Finally, we also propose an exceptional case, *i.e.* circular quivers involving G_2 , $USp(4)$ and $SO(5)$ gauge nodes where a $T[G_2]$ link has been inserted. In both case, with and without S-fold, we construct mirror pairs involving this exceptional group and we checked the consistency against mirror symmetry.

It would interesting to understand the stringy origin of exceptional models: in fact, in this case we do not have any brane construction at disposal but we used field-theoretical arguments only. It is natural to think that explanation of this exceptional configuration need some exotic construction for instance in F-theory. Having such construction at disposal could also shed a light about the possibility of building models involving $T[G]$ theories for $G = E_{6,7,8}$ or $G = F_4$.

We also studied the moduli space J -fold SCFTs. The presence of non-trivial CS levels makes the study much harder and we focused on the Abelian case only, since Lagrangian description of such theories is available. We computed the moduli space for selected examples and observed that it generically enjoys a rich and complicated structure of mixed branches. This is mostly due to the fact that monopole dynamics is more involved in the J -fold case. It would be interesting to understand if there exists a general rule to compute moduli space in the non-Abelian case. A similar problem also extends to the cases with more general $T[G]$ -links, for which we studied S-flip configurations only. Let us stress that introduction of a non-trivial CS levels would allow to build configuration with T-links for non self-Langland groups $SO(2N + 1)$ and $USp(2N)$.

We also addressed the problem of the infrared amount of supersymmetry of an S-fold theory, computing the superconformal index of various models and using the results of [80, 82, 85] to read possible signals of supersymmetry enhancement. More in general, we also looked for other interesting phenomena such as dualities or global symmetry enhancement. We found evidence that S-flip theories in general have $\mathcal{N} = 3$ supersymmetry in the IR while J -fold theories enjoy enhancement to $\mathcal{N} = 4$ and possibly $\mathcal{N} = 5$. It would be interesting to study the origin of supersymmetry enhancement in terms of fields in the quiver description.

The study S-fold SCFTs can be thought as a first step of a more general program. In fact, as review in section 3.1, a $T[SU(N)]$ theory naturally appears as the boundary theory on an S-duality wall for $4d \mathcal{N} = 4$ SYM. For this reason, one could think that more exotic T -links can be studied, each arising as some boundary theory on an $SL(2, \mathbb{Z})$ duality wall. For instance, following [15], a $T_{\rho}^{\sigma}[G]$ theory can be thought as the theory on the wall for $\mathcal{N} = 4$ SYM with varying coupling constant and appropriate boundary conditions at the interface. Understanding whether quivers involving $T_{\rho}^{\sigma}[G]$ links can be built consistently with mirror symmetry is a natural generalization. Moreover, one could think to consider theories on duality walls for ancestor theories in four dimensions that differs from $\mathcal{N} = 4$ SYM and thus having a lower amount of supersymmetry. A first step in this direction has been carried out in [87] where a new link has been proposed, consisting of the theory on an S-duality wall for $4d SU(N) \mathcal{N} = 2$ SYM with $2N$ flavors and varying coupling constant. Such boundary theory has been proposed in [88]. The authors of [87] considered various quivers with one or more insertion of such link, computing the supersymmetric index and looking for signals of supersymmetry enhancement, global symmetry enhancement or dualities. It could be interesting understand if other links preserving $\mathcal{N} = 2$ supersymmetry only can be considered, possibly looking for new boundary theories living on $SL(2, \mathbb{Z})$ duality walls.

Finally, another open problem is whether it is possible to perform an $SL(2, \mathbb{Z})$ quotient of other Type-IIB known supergravity solution in other dimensions. A remarkable class of backgrounds where this is in principle possible consists of the AdS_6 solutions of [89–91]. It would be interesting to study to understand how a background with monodromy can be constructed in this case and studying, in the case of positive answer, its holographic counterpart in quantum field theory.

Appendices

Appendix A

Hilbert series

A.1 The monopole formula

The monopole formula proposed in [30] allows to compute the Hilbert series for the Coulomb branch of $\mathcal{N} = 4$ theories. In particular it allows to take into account the contributions to the dynamics of monopoles, whose expectation value parametrize the Coulomb branch. The prescription of the monopole formula requires three main objects:

- The R-charge of BPS bare monopoles; as already observed in (2.19), it depends on the GNO magnetic charges, collectively denoted by \mathbf{m} . In the $\mathcal{N} = 4$ case, such R-charge has the following compact form:

$$\Delta(\mathbf{m}) = - \sum_{\alpha \in \Delta_+} |\alpha(\mathbf{m})| + \frac{1}{2} \sum_i \sum_{\rho_i \in \mathcal{R}_i} |\rho_i(\mathbf{m})|. \quad (\text{A.1})$$

Δ_+ is the set of all positive roots of the gauge group and the first sum represents the contribution of all the $\mathcal{N} = 4$ vector multiplets. The second sum in (A.1) is instead the contribution of all the hypermultiplets in the theory, labeled by i : each of them is assumed to transform in some representation \mathcal{R}_i of the gauge group, with weights $\{\rho_i\}$. Observe that one should be sure that $\Delta(\mathbf{m}) > 1/2$: otherwise, some monopole saturates or violates the unitarity bound and the theory is ugly or bad in the sense of [15].

- The other ingredient that is needed is the “classical factor”: such contribution, depending again on the choice of magnetic charges, takes into account the breaking of the gauge group because of \mathbf{m} . We will denote such contribution with $P_G(t; \mathbf{m})$ where t is the R -symmetry fugacity as usual. We will provide in the following of the section some examples of classical factors.
- Finally, we can add a contribution taking trace of the charge under topological symmetries of the monopoles. We introduce a fugacity z_a for each topological symmetry (*i.e.* for each $U(1)$ factor in the center of the gauge group) and we add the following factor to the Hilbert series:

$$(z_a)^{J_a(\mathbf{m})}, \quad (\text{A.2})$$

where J_a is the topological charge of the monopole, having an explicit dependence on the GNO charges, as already observed in section (2.2).

The Hilbert series of a $\mathcal{N} = 4$ theory can be thus written in the following way:

$$H_C[t, z] = \sum_{\mathbf{m} \in \Lambda} t^{\Delta(\mathbf{m})} P_G(t; \mathbf{m}) \prod_a z_a^{J_a(\mathbf{m})}, \quad (\text{A.3})$$

where Λ is the magnetic lattice. Let us collect some classical factors used in the main text:

$$\begin{aligned} P_{U(1)}(t; m) &= (1 - t^2)^{-1} \\ P_{U(2)}(t; m_1, m_2) &= \begin{cases} (1 - t^2)^{-2}, & m_1 \neq m_2 \\ (1 - t^2)^{-1}(1 - t^4)^{-1}, & m_1 = m_2 \end{cases} \\ P_{C_2}(t; m_1, m_2) &= \begin{cases} (1 - t^2)^{-2} & m_1 > m_2 > 0 \\ (1 - t^2)^{-1}(1 - t^4)^{-1} & m_1 > m_2 = 0 \text{ or } m_1 = m_2 > 0 \\ (1 - t^4)^{-1}(1 - t^8)^{-1} & m_1 = m_2 = 0 \end{cases} \\ P_{G_2}(t; m_1, m_2) &= \begin{cases} (1 - t^2)^{-2} & m_1 > m_2 > 0 \\ (1 - t^2)^{-1}(1 - t^4)^{-1} & m_1 = 0, m_2 > 0 \text{ or } m_1 > 0, m_2 = 0 \\ (1 - t^4)^{-1}(1 - t^{12})^{-1} & m_1 = m_2 = 0 \end{cases}. \end{aligned} \quad (\text{A.4})$$

Finally, in order also to fix some notation used in the main text, let us write down some examples of the contribution to the monopole R -charge coming from matter in the bi-fundamental or adjoint representation of $U(N)$:

$$\begin{aligned} 2\Delta_{U(N_1)-U(N_2)}(\mathbf{m}, \mathbf{n}) &= \sum_{i=1}^{N_1} \sum_{j=1}^{N_2} |m_i - n_j| \\ \Delta_{U(N)}^{\text{vec}}(\mathbf{m}) &= \frac{1}{2} \sum_{i=1}^N \sum_{j=1}^N |m_i - m_j| \end{aligned} \quad (\text{A.5})$$

and the contribution coming from matter in bi-fundamental or adjoint representation of G_2 and $USp(4)$:

$$\begin{aligned} 2\Delta_{G_2-C_2}^{\text{hyp}}(\mathbf{n}, \mathbf{a}) &= \frac{1}{2} \sum_{\pm} \sum_{i=1}^2 \left[|n_1 \pm a_i| + |n_1 + n_2 \pm a_i| + |2n_1 + n_2 \pm a_i| + \right. \\ &\quad \left. + (n_1 \rightarrow -n_1, n_2 \rightarrow -n_2) + |\pm a_i| \right] \\ \Delta_{G_2}^{\text{vec}}(\mathbf{n}) &= |n_1| + |n_2| + |n_1 + n_2| + |2n_1 + n_2| + |3n_1 + n_2| + |3n_1 + 2n_2| \\ \Delta_{C_2}^{\text{vec}}(\mathbf{a}) &= |2a_1| + |2a_2| + |a_1 + a_2| + |a_1 - a_2|. \end{aligned} \quad (\text{A.6})$$

A.2 Coupling hypermultiplets to a nilpotent cone

In this section we study the hyperkähler space that arises from coupling hypermultiplets or half-hypermultiplets to nilpotent cone \mathcal{N}_g of the Lie algebra g

theory, namely that of the quiver $[U(n)] - (U(2)) - (U(1))$. The quaternionic dimension of this is precisely $2n - 3$. This is indeed in agreement with (A.12).

For a general N , such that $n \geq N + 1$, we see that $\mathcal{H}_{(A.10)}$ is in fact

$$\mathcal{H}_{(A.10)} = \overline{\mathcal{O}}_{(N+1, 1^{n-N-1})} , \quad (\text{A.13})$$

and in the special case of $n = N$, we have the nilpotent cone of $su(N)$:

$$\mathcal{H}_{(A.10)}|_{n=N} = \overline{\mathcal{O}}_{(N)} = \mathcal{N}_{su(N)} . \quad (\text{A.14})$$

One way to verify this proposition is to compute the Hilbert series of $\mathcal{H}_{(A.10)}$. This is given by¹

$$\begin{aligned} H[\mathcal{H}_{(A.10)}](t; \mathbf{x}) &= \int d\mu_{SU(N)}(\mathbf{z}) \oint_{|q|=1} \frac{dq}{2\pi i q} \text{PE} \left[\chi_{[1,0,\dots,0]}^{su(N)}(\mathbf{x}) \chi_{[0,\dots,0,1]}^{su(N)}(\mathbf{z}) q^{-1} t \right. \\ &\quad \left. + \chi_{[0,\dots,0,1]}^{su(N)}(\mathbf{x}) \chi_{[1,0,\dots,0]}^{su(N)}(\mathbf{z}) q - \chi_{[1,0,\dots,0,1]}^{su(N)}(\mathbf{z}) t^2 \right] H[\mathcal{N}_{su(N)}](t, \mathbf{z}) \end{aligned} \quad (\text{A.15})$$

where \mathbf{x} denotes the flavor fugacities of $su(N)$ and $d\mu_{SU(N)}(\mathbf{z})$ denotes the Haar measure of $SU(N)$. We refer the reader to the detail of the characters and the Haar measures in [92]. The Hilbert series of the nilpotent cone of $su(N)$ was computed in [47] and is given by

$$H[\mathcal{N}_{su(N)}](t, \mathbf{z}) = \text{PE} \left[\chi_{[1,0,\dots,0,1]}^{su(N)}(\mathbf{z}) t^2 - \sum_{p=2}^N t^{2p} \right] . \quad (\text{A.16})$$

The Hilbert series (A.15) can then be used to checked against the results presented in [53]. In this way, the required nilpotent orbits in (A.13) and (A.14) can be identified. This technique can also be applied to other gauge groups, as will be discussed in the subsequent subsections. For the sake of brevity of the presentation, we shall not go through further details.

We remark that for $n \geq 2N + 1$, the hyperkähler space (A.13) is isomorphic the Higgs branch of the $T_{(n-N, 1^N)}(SU(n))$ theory², which corresponds to the quiver [15]:

$$T_{(n-N, 1^N)}(SU(n)) : [U(n)] - (U(N)) - (U(N-1)) - \dots - (U(1)) . \quad (\text{A.17})$$

Note that quiver (A.10) can be obtained from (A.17) simply by replacing the wiggly line by the quiver tail as follows:

$$\begin{array}{c} \textcircled{N} \text{---} \text{wiggly line} \end{array} \longrightarrow (U(N)) - (U(N-1)) - \dots - (U(1)) . \quad (\text{A.18})$$

$G = USp(2N)$ **and** $H = O(n)$ **or** $SO(n)$

We take $G = USp(2N)$ and couple n half-hypermultiplets to G :

$$\begin{array}{c} \boxed{n} \text{---} \textcircled{2N} \text{---} \text{wiggly line} \end{array} \quad (\text{A.19})$$

¹The plethystic exponential (PE) of a multivariate function $f(x_1, x_2, \dots, x_n)$ such that $f(0, 0, \dots, 0) = 0$ is defined as $\text{PE}[f(x_1, x_2, \dots, x_n)] = \exp\left(\sum_{k=1}^{\infty} \frac{1}{k} f(x_1^k, x_2^k, \dots, x_n^k)\right)$.

²The partition $(n - N, 1^N)$ is indeed the transpose of the partition $(N + 1, 1^{n-N-1})$ in (A.13).

The corresponding hyperkähler quotient is

$$\mathcal{H}_{(A.19)} = \frac{\mathcal{H}([SO(n)] - [USp(2N)]) \times \mathcal{N}_{usp(2N)}}{USp(2N)}. \quad (A.20)$$

The dimension of this space is

$$\begin{aligned} \dim_{\mathbb{H}} \mathcal{H}_{(A.19)} &= nN + \frac{1}{2} \left[\frac{1}{2}(2N)(2N+1) - N \right] - \frac{1}{2}(2N)(2N+1) \\ &= N(n - N - 1). \end{aligned} \quad (A.21)$$

For $n \geq 2N + 1$, the hyperkähler quotient (A.20) turns out to be isomorphic to the closure of the nilpotent orbit $(2N + 1, 1^{n-(2N+1)})$ of $so(n)$:

$$\mathcal{H}_{(A.19)} = \overline{\mathcal{O}}_{(2N+1, 1^{n-(2N+1)})}. \quad (A.22)$$

For even n , say $n = 2m$, this is isomorphic to the Higgs branch of $T_{\rho}(SO(n))$, with $\rho = (n - 2N - 1, 1^{2N+1})$,³ whose quiver description is

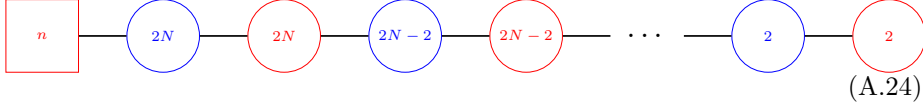

For odd n , say $n = 2m + 1$, this is isomorphic to the Higgs branch of $T_{\rho}(SO(n))$, with $\rho = (n - 2N - 1, 2, 1^{2N-2})$ if $n > 2N + 1$ and $\rho = (1^{2N})$ if $n = 2N + 1$,⁴ whose quiver description is

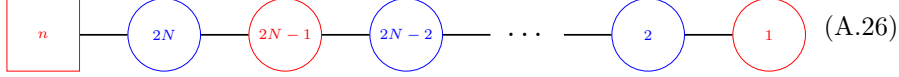

$G = SO(N)$ or $O(N)$ and $H = USp(2n)$

Let us first take $G = SO(N)$ and take $H = USp(2n)$.



This diagram defines the hyperkähler quotient

$$\mathcal{H}_{(A.27)} = \frac{\mathcal{H}([USp(2n)] - [SO(N)]) \times \mathcal{N}_{so(N)}}{SO(N)}. \quad (A.28)$$

³Note that the partition $\rho = (n - 2N - 1, 1^{2N+1})$ can be obtained from the partition $\lambda = (2N + 1, 1^{n-(2N+1)})$ of (A.22) by first computing the transpose of λ , and then performing the D -collapse. For example, for $N = 2$ and $m = 4$ (or $n = 8$),

$$\lambda = (5, 1^4) \xrightarrow{\text{transpose}} (4, 1^4) \xrightarrow{D\text{-coll.}} \rho = (3, 1^5). \quad (A.23)$$

⁴Note that the partition $\rho = (n - 2N - 1, 2, 1^{2N-2})$ can be obtained from the partition $\lambda = (2N + 1, 1^{n-(2N+1)})$ of (A.22) by first computing the transpose of λ , subtracting 1 from the last entry, and then performing the C -collapse. For example, for $N = 3$ and $m = 4$ (or $n = 9$),

$$\lambda = (7, 1^2) \xrightarrow{\text{transpose}} (3, 1^6) \longrightarrow (3, 1^5) \xrightarrow{C\text{-coll.}} (2^2, 1^4). \quad (A.25)$$

The quaternionic dimension of this quotient is

$$\dim_{\mathbb{H}} \mathcal{H}_{(A.27)} = \begin{cases} m(2n - m) , & N = 2m \\ m(2n - m - 1) + n , & N = 2m + 1 \end{cases} . \quad (\text{A.29})$$

It is interesting to examine (A.28) for a few special cases. For $N = 2n$ or $N = 2n + 1$ or $N = 2n - 1$, we find that (A.28) is in fact the nilpotent cone $\mathcal{N}_{usp(2n)}$ of $usp(2n)$, whose quaternionic dimension is n^2 :

$$\mathcal{H}_{(A.27)}|_{N=2n} = \mathcal{H}_{(A.27)}|_{N=2n\pm 1} = \mathcal{N}_{usp(2n)} . \quad (\text{A.30})$$

This statement can be checked using the Hilbert series:

$$\begin{aligned} H[\mathcal{H}_{(A.27)}](t; \mathbf{x}) &= \int d\mu_{SO(N)}(\mathbf{z}) \text{PE} \left[\chi_{[1,0,\dots,0]}^{C_n}(\mathbf{x}) \chi_{[1,0,\dots,0]}^{so(N)}(\mathbf{z}) t \right. \\ &\quad \left. - \chi_{[0,1,0,\dots,0]}^{so(N)}(\mathbf{z}) t^2 \right] H[\mathcal{N}_{so(N)}](t, \mathbf{z}) \\ &= \text{PE} \left[\chi_{[2,0,\dots,0]}^{C_n}(\mathbf{x}) t^2 - \sum_{j=1}^n t^{4j} \right] , \text{ if } N = 2n \text{ or } 2n \pm 1 . \end{aligned} \quad (\text{A.31})$$

where the Haar measure and the relevant characters are given in [92]. The last line is indeed the Hilbert series of the nilpotent cone $\mathcal{N}_{usp(2n)}$ [53].

It is important to note that the quotient (A.28) is not the closure of a nilpotent orbit in general. For example, let us take $n = 4$ and $N = 3$, *i.e.* $G = SO(3)$ and $H = USp(8)$. The Hilbert series takes the form

$$H[\mathcal{H}_{(A.27)}|_{n=4, N=3}](t; \mathbf{x}) = \text{PE} \left[\chi_{[2,0,0,0]}^{C_4} t^2 + (\chi_{[0,0,1,0]}^{C_4} + \chi_{[1,0,0,0]}^{C_4}) t^3 - t^4 + \dots \right] . \quad (\text{A.32})$$

Observe that there are generators with $SU(2)_R$ -spin $3/2$ in the third rank anti-symmetric representation $\wedge^3[1, 0, 0, 0] = [0, 0, 1, 0] + [1, 0, 0, 0]$ of $USp(8)$. These should be identified as ‘‘baryons’’. Using Namikawa’s theorem [93], which states that all generators of the closure of a nilpotent orbit must have $SU(2)_R$ -spin 1 (see also [94]), we conclude that $\mathcal{H}_{(A.27)}|_{n=4, N=3}$ is not the closure of a nilpotent orbit. In general, these baryons can be removed by taking gauge group to be $O(N)$, instead of $SO(N)$. The reason is because the $O(N)$ group does not have an epsilon tensor as an invariant tensor, whereas the $SO(N)$ group has one.

Let us now take $G = O(N)$ and take $H = USp(2n)$:

$$\begin{array}{c} \boxed{2n} \text{---} \bigcirc(O(N)) \text{---} \text{wavy line} \end{array} \quad (\text{A.33})$$

This diagram defines the hyperkähler quotient

$$\mathcal{H}_{(A.33)} = \frac{\mathcal{H}([USp(2n)] - [O(N)]) \times \mathcal{N}_{so(N)}}{O(N)} . \quad (\text{A.34})$$

The dimension of this hyperkähler space is the same as (A.29). This quotient turns out to be isomorphic to the closure of the following nilpotent orbit of $usp(2n)$:

$$\mathcal{H}_{(A.33)} = \begin{cases} \overline{\mathcal{O}}_{(N, 2, 1^{2n-N-2})} & N \text{ even} \\ \overline{\mathcal{O}}_{(N+1, 1^{2n-N-1})} & N \text{ odd} \end{cases} . \quad (\text{A.35})$$

In the special case where $N = 2n$, $N = 2n - 1$ or $N = 2n + 1$, we have

$$\mathcal{H}_{(A.33)}|_{N=2n} = \mathcal{H}_{(A.33)}|_{N=2n\pm 1} = \overline{\mathcal{O}}_{(2n)} = \mathcal{N}_{usp(2n)} , \quad (A.36)$$

which is the same as (A.30).

For even $N = 2m$, $\mathcal{H}_{(A.33)}$ is isomorphic to the Higgs branch of $T_\rho(USp(2n))$ theory, with $\rho = (2n - N + 1, 1^N)$, whose quiver description is

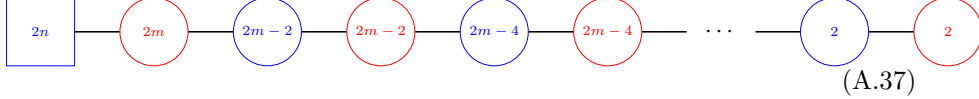

On the other hand, for odd $N = 2m + 1$, $\mathcal{H}_{(A.33)}$ is isomorphic to the Higgs branch of $T_\rho(USp'(2n))$ theory, with $\rho = (2n - N + 1, 1^{N-1})$, whose quiver description is

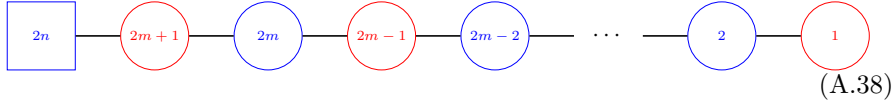

$G = G_2$ and $H = USp(2n)$

We take $G = G_2$ and $H = USp(2n)$:



This diagram defines the hyperkähler quotient

$$\mathcal{H}_{(A.39)} = \frac{\mathcal{H}([USp(2n)] - [G_2]) \times \mathcal{N}_{g_2}}{G_2} . \quad (A.40)$$

For $n \geq 2$, the quaternionic dimension of this space is

$$\dim_{\mathbb{H}} \mathcal{H}_{(A.39)} = 7n + \frac{1}{2}(14 - 2) - 14 = 7n - 8 , \quad (A.41)$$

and the Hilbert series of (A.40) is given by

$$H[\mathcal{H}_{(A.40)}](t, \mathbf{x}) = \int d\mu_{G_2}(\mathbf{z}) \text{PE} \left[\chi_{[1,0]}^{G_2}(\mathbf{z}) \chi_{[1,0,\dots,0]}^{usp(2n)}(\mathbf{x}) t - \chi_{[0,1]}^{G_2}(\mathbf{z}) t^2 \right] H[\mathcal{N}_{g_2}](t, \mathbf{z}) , \quad (A.42)$$

where the relevant characters and the Haar measure is given in [92], and the Hilbert series of the nilpotent cone of G_2 can be obtained from [54]. The special case of $n = 2$ is particularly simple. The corresponding space is a complete intersection whose Hilbert series is

$$H[\mathcal{H}_{(A.39)}|_{n=2}](t; x_1, x_2) = \text{PE} \left[\chi_{[2,0]}^{C_2}(x_1, x_2) t^2 + \chi_{[1,0]}^{C_2}(x_1, x_2) t^3 - t^8 - t^{12} \right] . \quad (A.43)$$

Note that $\mathcal{H}_{(A.39)}$ is not the closure of a nilpotent orbit, due to the existence of a generator at $SU(2)_R$ -spin 3/2 and Namikawa's theorem.

The case of $n = 1$ needs to be treated separately, since (A.41) becomes negative. We claim that

$$\mathcal{H}_{(A.39)}|_{n=1} = \mathbb{C}^2/\mathbb{Z}_2 = \mathcal{N}_{su(2)} . \quad (A.44)$$

The reason is as follows. Let us denote by Q_a^i the half-hypermultiplets in the fundamental representation of the G_2 gauge group⁵, where $i, j, k = 1, 2$ are the $USp(2)$ flavor indices and $a, b, c, d = 1, \dots, 7$ are the G_2 gauge indices. Let us also denote by X_{ab} the generators of the nilpotent cone of G_2 . Transforming in the adjoint representation of G_2 , X_{ab} is an antisymmetric matrix satisfying⁶

$$f^{abc} X_{ab} = 0 ; \quad (A.45)$$

this is because $\wedge^2[1, 0] = [0, 1] + [1, 0]$. Moreover, being the generators of the nilpotent cone, X_{ab} satisfy

$$\text{tr}(X^2) = \delta^{ad}\delta^{bc} X_{ab}X_{cd} = 0 , \quad \text{tr}(X^6) = 0 . \quad (A.46)$$

The moment map equations for G_2 read

$$\epsilon_{ij} Q_a^i Q_b^j = X_{ab} . \quad (A.47)$$

The generators of (A.40), for $n = 1$, are

$$M^{ij} = \delta_{ab} Q_a^i Q_b^j \quad (A.48)$$

transforming in the adjoint representation of $USp(2)$. Note that baryons vanish:

$$f^{abc} Q_a^i Q_b^j Q_c^k = 0 , \quad \tilde{f}^{abcd} Q_a^i Q_b^j Q_c^k Q_d^l = 0 , \quad (A.49)$$

because $i, j, k, l = 1, 2$. Other gauge invariant combinations also vanish; for example, $X_{ab} Q_a^i Q_b^j$ has one independent component and it vanishes thanks to (A.46) and (A.47). Furthermore, the square of M vanishes:

$$\epsilon_{il}\epsilon_{jk} M^{ij} M^{kl} = (\epsilon_{il} Q_a^i Q_b^l)(\epsilon_{jk} Q_a^j Q_b^k) \stackrel{(A.47)}{=} \text{tr}(X^2) \stackrel{(A.46)}{=} 0 . \quad (A.50)$$

Therefore, we reach the conclusion (A.44).

⁵The three independent invariant tensors for G_2 can be taken as (1) the Kronecker delta δ^{ab} , (2) the third-rank antisymmetric tensor f^{abc} and (3) the fourth-rank antisymmetric tensor \tilde{f}^{abcd} . See *e.g.* [95] for more details.

⁶Using the identity $f^{[abc} f^{cde]} = \tilde{f}^{abde}$ (see [95]), it follows immediately from this relation that $\tilde{f}^{abde} X_{ab} X_{de} = 0$.

Appendix B

Superconformal index

The supersymmetric index can be thought of as the supersymmetric partition function on $S^2 \times S^1$. It is defined as a trace over states on $S^2 \times \mathbb{R}$ [36, 96–100] (we also use the same notation as [101, 102]):

$$\mathcal{I}(x, \boldsymbol{\mu}) = \text{Tr} \left[(-1)^{2J_3} x^{\Delta+J_3} \prod_i \mu_i^{T_i} \right], \quad (\text{B.1})$$

where Δ is the energy in units of the S^2 radius (for superconformal field theories, Δ is related to the conformal dimension), J_3 is the Cartan generator of the Lorentz $SO(3)$ isometry of S^2 , and T_i are charges under non- R global symmetries. The index only receives contributions from the states that satisfy:

$$\Delta - R - J_3 = 0, \quad (\text{B.2})$$

where R is the R -charge. As a partition function on $S^2 \times S^1$, localization implies that the index receives contributions only from BPS configurations, and it can be written in the following compact way:

$$\mathcal{I}(x; \{\boldsymbol{\mu}, \mathbf{n}\}) = \sum_{\mathbf{m}} \frac{1}{|\mathcal{W}_{\mathbf{m}}|} \int \frac{d\mathbf{z}}{2\pi i \mathbf{z}} Z_{\text{cl}} Z_{\text{vec}} Z_{\text{mat}}, \quad (\text{B.3})$$

where we denoted by \mathbf{z} the fugacities parameterizing the maximal torus of the gauge group, and by \mathbf{m} the corresponding GNO magnetic fluxes on S^2 . Here $|\mathcal{W}_{\mathbf{m}}|$ is the dimension of the Weyl group of the residual gauge symmetry in the monopole background labelled by the configuration of magnetic fluxes \mathbf{m} . We also use $\{\boldsymbol{\mu}, \mathbf{n}\}$ to denote possible fugacities and fluxes for the background vector multiplets associated with global symmetries, respectively. As usual in localization computations, the index receives contributions from the non-exact terms of the classical action and from the 1-loop corrections, and each term in the above equation can be described as follows.

Z_{cl} : The classical contribution is associated to Chern-Simons and BF interactions only. Denoting with k the CS level and with ω and \mathbf{n} the fugacity and the background flux for the topological symmetry, the classical contribution takes the form

$$Z_{\text{cl}} = \prod_{i=1}^{\text{rk}G} \omega^{m_i} z_i^{k m_i + \mathbf{n}}, \quad (\text{B.4})$$

where $\text{rk}G$ is the rank of the gauge group G .

\mathbf{Z}_{vec} : This is the contribution of the $\mathcal{N} = 2$ vector multiplet in the theory:

$$Z_{\text{vec}} = \prod_{\alpha \in \mathfrak{g}} x^{-\frac{|\alpha(\mathbf{m})|}{2}} (1 - (-1)^{\alpha(\mathbf{m})} \mathbf{z}^\alpha x^{|\alpha(\mathbf{m})|}) \quad (\text{B.5})$$

where α are roots in the gauge algebra \mathfrak{g} .

\mathbf{Z}_{mat} : The term encoding the matter fields in the theory enters as the product of the contributions of each $\mathcal{N} = 2$ chiral field χ , transforming in some representation \mathcal{R} and \mathcal{R}_F of the gauge and the flavor symmetry respectively. Denoting by r_χ the R -charge of χ , its contribution to the index is of the form

$$Z_\chi = \prod_{\rho \in \mathcal{R}} \prod_{\tilde{\rho} \in \mathcal{R}_F} \left(\mathbf{z}^\rho \boldsymbol{\mu}^{\tilde{\rho}} x^{r_\chi - 1} \right)^{-\frac{|\rho(\mathbf{m}) + \tilde{\rho}(\mathbf{n})|}{2}} \times \\ \times \frac{(((-1)^{\rho(\mathbf{m}) + \tilde{\rho}(\mathbf{n})} \mathbf{z}^{-\rho} \boldsymbol{\mu}^{-\tilde{\rho}} x^{2 - r_\chi + |\rho(\mathbf{m}) + \tilde{\rho}(\mathbf{n})|}; x^2))_\infty}{(((-1)^{\rho(\mathbf{m}) + \tilde{\rho}(\mathbf{n})} \mathbf{z}^\rho \boldsymbol{\mu}^{\tilde{\rho}} x^{r_\chi + |\rho(\mathbf{m}) + \tilde{\rho}(\mathbf{n})|}; x^2))_\infty} \quad (\text{B.6})$$

where ρ and $\tilde{\rho}$ are the weights of \mathcal{R} and \mathcal{R}_F respectively.

Let us discuss some examples that will be used later. The $T[U(1)]$ theory is an almost empty theory, containing only the mixed CS coupling between two $U(1)$ background vector multiplets; its index is

$$\mathcal{I}_{T[U(1)]}(\{\boldsymbol{\mu}, \mathbf{n}\}, \{\boldsymbol{\tau}, \mathbf{p}\}) = \tau^n \mu^p. \quad (\text{B.7})$$

Next, we consider 3d $\mathcal{N} = 4$ $U(1)$ gauge theory with 2 flavors, whose SCFT is known as $T[SU(2)]$. The index of this theory is

$$\mathcal{I}_{T[SU(2)]}(\{\boldsymbol{\mu}, \mathbf{n}\}, \{\boldsymbol{\tau}, \mathbf{p}\}) \\ = \sum_{m \in \mathbb{Z}} \left(\frac{\tau_1}{\tau_2} \right)^m \oint \frac{dz}{2\pi i z} z^{n_1 - n_2} \prod_{a=1}^2 x^{\frac{|m - p_a|}{2}} \frac{(((-1)^{m - p_a} z^{\mp 1} \mu_a^{\pm 1} x^{3/2 + |m - p_a|}; x^2))_\infty}{(((-1)^{m - p_a} z^{\pm 1} \mu_a^{\mp 1} x^{1/2 + |m - p_a|}; x^2))_\infty}, \quad (\text{B.8})$$

with the conditions $\mu_1 \mu_2 = \tau_1 \tau_2 = 1$ and $n_1 + n_2 = p_1 + p_2 = 0$ being imposed.

Another important example is the index for $T[U(2)]$:

$$\mathcal{I}_{T[U(2)]}(\{\boldsymbol{\mu}, \mathbf{n}\}, \{\boldsymbol{\tau}, \mathbf{p}\}) \\ = \left[\prod_{i=1}^2 \mathcal{I}_{T[U(1)]}(\{\mu_i, n_i\}, \{\tau_i, p_i\}) \right] \times \mathcal{I}_{T[SU(2)]}(\{\boldsymbol{\mu}, \mathbf{n}\}, \{\boldsymbol{\tau}, \mathbf{p}\}), \quad (\text{B.9})$$

where in this expression there is no need to impose the constraints on $\{\boldsymbol{\mu}, \mathbf{n}\}, \{\boldsymbol{\tau}, \mathbf{p}\}$ as for $T[SU(2)]$. Hence we may regard $\{\boldsymbol{\mu}, \mathbf{n}\}$ as fugacities and fluxes for the flavor $U(2)$ symmetry, and $\{\boldsymbol{\tau}, \mathbf{p}\}$ as fugacities and fluxes for the enhanced $U(2)$ topological symmetry. The fact that $T[U(2)]$ is a self-mirror theory can be translated into the invariance of $\mathcal{I}_{T[U(2)]}(\{\boldsymbol{\mu}, \mathbf{n}\}, \{\boldsymbol{\tau}, \mathbf{p}\})$ under the simultaneous exchange $\boldsymbol{\mu} \leftrightarrow \boldsymbol{\tau}, \mathbf{n} \leftrightarrow \mathbf{p}$. For our purpose, we usually turn off background magnetic fluxes.

Bibliography

- [1] C. Montonen and D. I. Olive, “Magnetic Monopoles as Gauge Particles?,” *Phys. Lett.* **72B** (1977) 117–120.
- [2] A. Hanany and E. Witten, “Type IIB superstrings, BPS monopoles, and three-dimensional gauge dynamics,” *Nucl.Phys.* **B492** (1997) 152–190, [arXiv:hep-th/9611230](#) [hep-th].
- [3] E. D’Hoker, J. Estes, and M. Gutperle, “Exact half-BPS Type IIB interface solutions. I. Local solution and supersymmetric Janus,” *JHEP* **06** (2007) 021, [arXiv:0705.0022](#) [hep-th].
- [4] B. Assel, C. Bachas, J. Estes, and J. Gomis, “Holographic Duals of D=3 N=4 Superconformal Field Theories,” *JHEP* **08** (2011) 087, [arXiv:1106.4253](#) [hep-th].
- [5] B. Assel, C. Bachas, J. Estes, and J. Gomis, “IIB Duals of D=3 N=4 Circular Quivers,” *JHEP* **12** (2012) 044, [arXiv:1210.2590](#) [hep-th].
- [6] B. Assel, J. Estes, and M. Yamazaki, “Large N Free Energy of 3d N=4 SCFTs and AdS_4/CFT_3 ,” *JHEP* **09** (2012) 074, [arXiv:1206.2920](#) [hep-th].
- [7] J. de Boer, K. Hori, H. Ooguri, and Y. Oz, “Mirror symmetry in three-dimensional gauge theories, quivers and D-branes,” *Nucl. Phys.* **B493** (1997) 101–147, [arXiv:hep-th/9611063](#) [hep-th].
- [8] M. Porrati and A. Zaffaroni, “M theory origin of mirror symmetry in three-dimensional gauge theories,” *Nucl.Phys.* **B490** (1997) 107–120, [arXiv:hep-th/9611201](#) [hep-th].
- [9] K. A. Intriligator and N. Seiberg, “Mirror symmetry in three-dimensional gauge theories,” *Phys. Lett.* **B387** (1996) 513–519, [arXiv:hep-th/9607207](#) [hep-th].
- [10] O. Aharony, A. Hanany, K. A. Intriligator, N. Seiberg, and M. J. Strassler, “Aspects of N=2 supersymmetric gauge theories in three-dimensions,” *Nucl. Phys.* **B499** (1997) 67–99, [arXiv:hep-th/9703110](#) [hep-th].
- [11] J. de Boer, K. Hori, and Y. Oz, “Dynamics of N=2 supersymmetric gauge theories in three-dimensions,” *Nucl. Phys.* **B500** (1997) 163–191, [arXiv:hep-th/9703100](#) [hep-th].

- [12] O. Aharony and A. Hanany, “Branes, superpotentials and superconformal fixed points,” *Nucl. Phys.* **B504** (1997) 239–271, [arXiv:hep-th/9704170](#) [hep-th].
- [13] O. Aharony, A. Hanany, and B. Kol, “Webs of (p,q) five-branes, five-dimensional field theories and grid diagrams,” *JHEP* **01** (1998) 002, [arXiv:hep-th/9710116](#) [hep-th].
- [14] E. Witten, “SL(2,Z) action on three-dimensional conformal field theories with Abelian symmetry,” [arXiv:hep-th/0307041](#) [hep-th].
- [15] D. Gaiotto and E. Witten, “S-Duality of Boundary Conditions In N=4 Super Yang-Mills Theory,” *Adv. Theor. Math. Phys.* **13** no. 3, (2009) 721–896, [arXiv:0807.3720](#) [hep-th].
- [16] O. Aharony, O. Bergman, D. L. Jafferis, and J. Maldacena, “N=6 superconformal Chern-Simons-matter theories, M2-branes and their gravity duals,” *JHEP* **10** (2008) 091, [arXiv:0806.1218](#) [hep-th].
- [17] B. Assel, “Hanany-Witten effect and SL(2, Z) dualities in matrix models,” *JHEP* **10** (2014) 117, [arXiv:1406.5194](#) [hep-th].
- [18] D. R. Gulotta, C. P. Herzog, and S. S. Pufu, “From Necklace Quivers to the F-theorem, Operator Counting, and T(U(N)),” *JHEP* **12** (2011) 077, [arXiv:1105.2817](#) [hep-th].
- [19] B. Assel and A. Tomasiello, “Holographic duals of 3d S-fold CFTs,” *JHEP* **06** (2018) 019, [arXiv:1804.06419](#) [hep-th].
- [20] G. Inverso, H. Samtleben, and M. Trigiante, “Type II supergravity origin of dyonic gaugings,” *Phys. Rev.* **D95** no. 6, (2017) 066020, [arXiv:1612.05123](#) [hep-th].
- [21] I. Garca-Etxebarria and D. Regalado, “ $\mathcal{N} = 3$ four dimensional field theories,” *JHEP* **03** (2016) 083, [arXiv:1512.06434](#) [hep-th].
- [22] O. Aharony and Y. Tachikawa, “S-folds and 4d N=3 superconformal field theories,” *JHEP* **06** (2016) 044, [arXiv:1602.08638](#) [hep-th].
- [23] C. Couzens, C. Lawrie, D. Martelli, S. Schafer-Nameki, and J.-M. Wong, “F-theory and AdS₃/CFT₂,” *JHEP* **08** (2017) 043, [arXiv:1705.04679](#) [hep-th].
- [24] C. Couzens, D. Martelli, and S. Schafer-Nameki, “F-theory and AdS₃/CFT₂ (2, 0),” *JHEP* **06** (2018) 008, [arXiv:1712.07631](#) [hep-th].
- [25] Y. Terashima and M. Yamazaki, “SL(2,R) Chern-Simons, Liouville, and Gauge Theory on Duality Walls,” *JHEP* **08** (2011) 135, [arXiv:1103.5748](#) [hep-th].
- [26] D. Gang, N. Kim, M. Romo, and M. Yamazaki, “Aspects of Defects in 3d-3d Correspondence,” *JHEP* **10** (2016) 062, [arXiv:1510.05011](#) [hep-th].

- [27] D. Gang and K. Yonekura, “Symmetry enhancement and closing of knots in 3d/3d correspondence,” *JHEP* **07** (2018) 145, [arXiv:1803.04009 \[hep-th\]](#).
- [28] I. Garozzo, G. Lo Monaco, N. Mekareeya, and M. Sacchi, “Supersymmetric Indices of 3d S -fold SCFTs,” *JHEP* **08** (2019) 008, [arXiv:1905.07183 \[hep-th\]](#).
- [29] I. Garozzo, G. Lo Monaco, and N. Mekareeya, “The moduli spaces of S -fold CFTs,” *JHEP* **01** (2019) 046, [arXiv:1810.12323 \[hep-th\]](#).
- [30] S. Cremonesi, A. Hanany, and A. Zaffaroni, “Monopole operators and Hilbert series of Coulomb branches of $3d \mathcal{N} = 4$ gauge theories,” *JHEP* **01** (2014) 005, [arXiv:1309.2657 \[hep-th\]](#).
- [31] I. Garozzo, G. Lo Monaco, and N. Mekareeya, “Variations on S -fold CFTs,” *JHEP* **03** (2019) 171, [arXiv:1901.10493 \[hep-th\]](#).
- [32] V. Borokhov, A. Kapustin, and X.-k. Wu, “Topological disorder operators in three-dimensional conformal field theory,” *JHEP* **11** (2002) 049, [arXiv:hep-th/0206054 \[hep-th\]](#).
- [33] F. Englert and P. Windey, “Quantization Condition for ’t Hooft Monopoles in Compact Simple Lie Groups,” *Phys. Rev.* **D14** (1976) 2728.
- [34] V. Borokhov, “Monopole operators in three-dimensional $N=4$ SYM and mirror symmetry,” *JHEP* **03** (2004) 008, [arXiv:hep-th/0310254 \[hep-th\]](#).
- [35] F. Benini, C. Closset, and S. Cremonesi, “Quantum moduli space of Chern-Simons quivers, wrapped D6-branes and AdS4/CFT3,” *JHEP* **09** (2011) 005, [arXiv:1105.2299 \[hep-th\]](#).
- [36] Y. Imamura and S. Yokoyama, “Index for three dimensional superconformal field theories with general R-charge assignments,” *JHEP* **04** (2011) 007, [arXiv:1101.0557 \[hep-th\]](#).
- [37] I. Affleck, J. A. Harvey, and E. Witten, “Instantons and (Super)Symmetry Breaking in (2+1)-Dimensions,” *Nucl. Phys.* **B206** (1982) 413–439.
- [38] P. C. Argyres, M. R. Plesser, and N. Seiberg, “The Moduli space of vacua of $N=2$ SUSY QCD and duality in $N=1$ SUSY QCD,” *Nucl. Phys.* **B471** (1996) 159–194, [arXiv:hep-th/9603042 \[hep-th\]](#).
- [39] N. Seiberg, “IR dynamics on branes and space-time geometry,” *Phys. Lett.* **B384** (1996) 81–85, [arXiv:hep-th/9606017 \[hep-th\]](#).
- [40] N. Seiberg and E. Witten, “Gauge dynamics and compactification to three-dimensions,” in *The mathematical beauty of physics: A memorial volume for Claude Itzykson. Proceedings, Conference, Saclay, France, June 5-7, 1996*, pp. 333–366. 1996. [arXiv:hep-th/9607163 \[hep-th\]](#).

- [41] F. Carta and H. Hayashi, “Hilbert series and mixed branches of $T[SU(N)]$ theory,” *JHEP* **02** (2017) 037, [arXiv:1609.08034 \[hep-th\]](#).
- [42] S. Cremonesi, N. Mekareeya, and A. Zaffaroni, “The moduli spaces of 3d $\mathcal{N} \geq 2$ Chern-Simons gauge theories and their Hilbert series,” *JHEP* **10** (2016) 046, [arXiv:1607.05728 \[hep-th\]](#).
- [43] S. Cremonesi, “3d supersymmetric gauge theories and Hilbert series,” *Proc. Symp. Pure Math.* **98** (2018) 21–48, [arXiv:1701.00641 \[hep-th\]](#).
- [44] S. Benvenuti, A. Hanany, and N. Mekareeya, “The Hilbert Series of the One Instanton Moduli Space,” *JHEP* **1006** (2010) 100, [arXiv:1005.3026 \[hep-th\]](#).
- [45] S. Benvenuti and S. Pasquetti, “3D-partition functions on the sphere: exact evaluation and mirror symmetry,” *JHEP* **05** (2012) 099, [arXiv:1105.2551 \[hep-th\]](#).
- [46] T. Nishioka, Y. Tachikawa, and M. Yamazaki, “3d Partition Function as Overlap of Wavefunctions,” *JHEP* **08** (2011) 003, [arXiv:1105.4390 \[hep-th\]](#).
- [47] A. Hanany and N. Mekareeya, “Complete Intersection Moduli Spaces in $N=4$ Gauge Theories in Three Dimensions,” *JHEP* **01** (2012) 079, [arXiv:1110.6203 \[hep-th\]](#).
- [48] S. Cremonesi, A. Hanany, N. Mekareeya, and A. Zaffaroni, “Coulomb branch Hilbert series and Hall-Littlewood polynomials,” *JHEP* **09** (2014) 178, [arXiv:1403.0585 \[hep-th\]](#).
- [49] S. Cremonesi, A. Hanany, N. Mekareeya, and A. Zaffaroni, “ $T_\rho^\sigma(G)$ theories and their Hilbert series,” *JHEP* **01** (2015) 150, [arXiv:1410.1548 \[hep-th\]](#).
- [50] S. Cremonesi, A. Hanany, N. Mekareeya, and A. Zaffaroni, “Coulomb branch Hilbert series and Three Dimensional Sicilian Theories,” *JHEP* **09** (2014) 185, [arXiv:1403.2384 \[hep-th\]](#).
- [51] C. Bachas, I. Lavdas, and B. Le Floch, “Marginal Deformations of 3d $N=4$ Linear Quiver Theories,” [arXiv:1905.06297 \[hep-th\]](#).
- [52] D. H. Collingwood and W. M. McGovern, “Nilpotent Orbits In Semisimple Lie Algebra,” *Van Nostrand Reinhold* (1993) .
- [53] A. Hanany and R. Kalveks, “Quiver Theories for Moduli Spaces of Classical Group Nilpotent Orbits,” *JHEP* **06** (2016) 130, [arXiv:1601.04020 \[hep-th\]](#).
- [54] A. Hanany and R. Kalveks, “Quiver Theories and Formulae for Nilpotent Orbits of Exceptional Algebras,” *JHEP* **11** (2017) 126, [arXiv:1709.05818 \[hep-th\]](#).
- [55] S. Cabrera, A. Hanany, and R. Kalveks, “Quiver Theories and Formulae for Slodowy Slices of Classical Algebras,” [arXiv:1807.02521 \[hep-th\]](#).

- [56] E. Witten, “Baryons and branes in anti-de Sitter space,” *JHEP* **07** (1998) 006, [arXiv:hep-th/9805112](#) [[hep-th](#)].
- [57] R. C. Myers, “Dielectric branes,” *JHEP* **12** (1999) 022, [arXiv:hep-th/9910053](#) [[hep-th](#)].
- [58] A. Kapustin and M. J. Strassler, “On mirror symmetry in three-dimensional Abelian gauge theories,” *JHEP* **04** (1999) 021, [arXiv:hep-th/9902033](#) [[hep-th](#)].
- [59] A. Hanany and N. Mekareeya, “Tri-vertices and SU(2)’s,” *JHEP* **02** (2011) 069, [arXiv:1012.2119](#) [[hep-th](#)].
- [60] A. Hanany and G. Zafrir, “Discrete Gauging in Six Dimensions,” *JHEP* **07** (2018) 168, [arXiv:1804.08857](#) [[hep-th](#)].
- [61] B. Assel, “The Space of Vacua of 3d $\mathcal{N} = 3$ Abelian Theories,” *JHEP* **08** (2017) 011, [arXiv:1706.00793](#) [[hep-th](#)].
- [62] A. Butti, D. Forcella, and A. Zaffaroni, “Counting BPS baryonic operators in CFTs with Sasaki-Einstein duals,” *JHEP* **06** (2007) 069, [arXiv:hep-th/0611229](#) [[hep-th](#)].
- [63] D. Forcella, A. Hanany, and A. Zaffaroni, “Baryonic Generating Functions,” *JHEP* **12** (2007) 022, [arXiv:hep-th/0701236](#) [[HEP-TH](#)].
- [64] A. Butti, D. Forcella, A. Hanany, D. Vegh, and A. Zaffaroni, “Counting Chiral Operators in Quiver Gauge Theories,” *JHEP* **11** (2007) 092, [arXiv:0705.2771](#) [[hep-th](#)].
- [65] D. L. Jafferis and X. Yin, “Chern-Simons-Matter Theory and Mirror Symmetry,” [arXiv:0810.1243](#) [[hep-th](#)].
- [66] D. Gaiotto and A. Tomasiello, “The gauge dual of Romans mass,” *JHEP* **01** (2010) 015, [arXiv:0901.0969](#) [[hep-th](#)].
- [67] O. J. Ganor, N. P. Moore, H.-Y. Sun, and N. R. Torres-Chicon, “Janus configurations with SL(2,Z)-duality twists, strings on mapping tori and a tridiagonal determinant formula,” *JHEP* **07** (2014) 010, [arXiv:1403.2365](#) [[hep-th](#)].
- [68] S. Benvenuti, B. Feng, A. Hanany, and Y.-H. He, “Counting BPS Operators in Gauge Theories: Quivers, Syzygies and Plethystics,” *JHEP* **11** (2007) 050, [arXiv:hep-th/0608050](#) [[hep-th](#)].
- [69] D. L. Jafferis, “Quantum corrections to $\mathcal{N} = 2$ Chern-Simons theories with flavor and their AdS₄ duals,” *JHEP* **08** (2013) 046, [arXiv:0911.4324](#) [[hep-th](#)].
- [70] P. Goddard, J. Nuyts, and D. I. Olive, “Gauge Theories and Magnetic Charge,” *Nucl. Phys.* **B125** (1977) 1–28.
- [71] A. Hanany and A. Zaffaroni, “Issues on orientifolds: On the brane construction of gauge theories with SO(2n) global symmetry,” *JHEP* **07** (1999) 009, [arXiv:hep-th/9903242](#) [[hep-th](#)].

- [72] B. Feng and A. Hanany, “Mirror symmetry by O3 planes,” *JHEP* **11** (2000) 033, [arXiv:hep-th/0004092](#) [[hep-th](#)].
- [73] A. Kapustin, “D(n) quivers from branes,” *JHEP* **12** (1998) 015, [arXiv:hep-th/9806238](#) [[hep-th](#)].
- [74] S. Cremonesi, G. Ferlito, A. Hanany, and N. Mekareeya, “Coulomb Branch and The Moduli Space of Instantons,” *JHEP* **12** (2014) 103, [arXiv:1408.6835](#) [[hep-th](#)].
- [75] A. Hanany and J. Troost, “Orientifold planes, affine algebras and magnetic monopoles,” *JHEP* **08** (2001) 021, [arXiv:hep-th/0107153](#) [[hep-th](#)].
- [76] A. Sen, “Stable nonBPS bound states of BPS D-branes,” *JHEP* **08** (1998) 010, [arXiv:hep-th/9805019](#) [[hep-th](#)].
- [77] M. J. Duff, H. Lu, and C. N. Pope, “Supersymmetry without supersymmetry,” *Phys. Lett.* **B409** (1997) 136–144, [arXiv:hep-th/9704186](#) [[hep-th](#)].
- [78] A. Gadde, E. Pomoni, and L. Rastelli, “The Veneziano Limit of $N = 2$ Superconformal QCD: Towards the String Dual of $N = 2$ $SU(N(c))$ SYM with $N(f) = 2 N(c)$,” [arXiv:0912.4918](#) [[hep-th](#)].
- [79] C. Beem and A. Gadde, “The $N = 1$ superconformal index for class S fixed points,” *JHEP* **04** (2014) 036, [arXiv:1212.1467](#) [[hep-th](#)].
- [80] S. S. Razamat and G. Zafrir, “Exceptionally simple exceptional models,” *JHEP* **11** (2016) 061, [arXiv:1609.02089](#) [[hep-th](#)].
- [81] F. A. Dolan, “On Superconformal Characters and Partition Functions in Three Dimensions,” *J. Math. Phys.* **51** (2010) 022301, [arXiv:0811.2740](#) [[hep-th](#)].
- [82] C. Cordova, T. T. Dumitrescu, and K. Intriligator, “Multiplets of Superconformal Symmetry in Diverse Dimensions,” *JHEP* **03** (2019) 163, [arXiv:1612.00809](#) [[hep-th](#)].
- [83] T. Dimofte and D. Gaiotto, “An E7 Surprise,” *JHEP* **10** (2012) 129, [arXiv:1209.1404](#) [[hep-th](#)].
- [84] M. Fazzi, A. Lanir, S. S. Razamat, and O. Sela, “Chiral 3d $SU(3)$ SQCD and $\mathcal{N} = 2$ mirror duality,” *JHEP* **11** (2018) 025, [arXiv:1808.04173](#) [[hep-th](#)].
- [85] M. Evtikhiev, “Studying superconformal symmetry enhancement through indices,” *JHEP* **04** (2018) 120, [arXiv:1708.08307](#) [[hep-th](#)].
- [86] D. Gang and M. Yamazaki, “Three-dimensional gauge theories with supersymmetry enhancement,” *Phys. Rev.* **D98** no. 12, (2018) 121701, [arXiv:1806.07714](#) [[hep-th](#)].
- [87] I. Garozzo, N. Mekareeya, and M. Sacchi, “Duality walls in the 4d $N = 2SU(N)$ gauge theory with $2N$ flavours,” [arXiv:1909.02832](#) [[hep-th](#)].

- [88] F. Benini, S. Benvenuti, and S. Pasquetti, “SUSY monopole potentials in 2+1 dimensions,” *JHEP* **08** (2017) 086, [arXiv:1703.08460 \[hep-th\]](#).
- [89] E. D’Hoker, M. Gutperle, A. Karch, and C. F. Uhlemann, “Warped $AdS_6 \times S^2$ in Type IIB supergravity I: Local solutions,” *JHEP* **08** (2016) 046, [arXiv:1606.01254 \[hep-th\]](#).
- [90] E. D’Hoker, M. Gutperle, and C. F. Uhlemann, “Warped $AdS_6 \times S^2$ in Type IIB supergravity II: Global solutions and five-brane webs,” *JHEP* **05** (2017) 131, [arXiv:1703.08186 \[hep-th\]](#).
- [91] E. D’Hoker, M. Gutperle, and C. F. Uhlemann, “Warped $AdS_6 \times S^2$ in Type IIB supergravity III: Global solutions with seven-branes,” *JHEP* **11** (2017) 200, [arXiv:1706.00433 \[hep-th\]](#).
- [92] A. Hanany, N. Mekareeya, and G. Torri, “The Hilbert Series of Adjoint SQCD,” *Nucl. Phys.* **B825** (2010) 52–97, [arXiv:0812.2315 \[hep-th\]](#).
- [93] Y. Namikawa, “A characterization of nilpotent orbit closures among symplectic singularities,” *Mathematische Annalen* **370** no. 1, (Feb, 2018) 811–818, [arXiv:1603.06105](#).
- [94] S. Cabrera and A. Hanany, “Branes and the Kraft-Procesi Transition,” *JHEP* **11** (2016) 175, [arXiv:1609.07798 \[hep-th\]](#).
- [95] S. B. Giddings and J. M. Pierre, “Some exact results in supersymmetric theories based on exceptional groups,” *Phys. Rev.* **D52** (1995) 6065–6073, [arXiv:hep-th/9506196 \[hep-th\]](#).
- [96] J. Bhattacharya, S. Bhattacharyya, S. Minwalla, and S. Raju, “Indices for Superconformal Field Theories in 3,5 and 6 Dimensions,” *JHEP* **02** (2008) 064, [arXiv:0801.1435 \[hep-th\]](#).
- [97] J. Bhattacharya and S. Minwalla, “Superconformal Indices for $N = 6$ Chern Simons Theories,” *JHEP* **01** (2009) 014, [arXiv:0806.3251 \[hep-th\]](#).
- [98] S. Kim, “The Complete superconformal index for $N=6$ Chern-Simons theory,” *Nucl. Phys.* **B821** (2009) 241–284, [arXiv:0903.4172 \[hep-th\]](#). [Erratum: *Nucl. Phys.*B864,884(2012)].
- [99] A. Kapustin and B. Willett, “Generalized Superconformal Index for Three Dimensional Field Theories,” [arXiv:1106.2484 \[hep-th\]](#).
- [100] T. Dimofte, D. Gaiotto, and S. Gukov, “3-Manifolds and 3d Indices,” *Adv. Theor. Math. Phys.* **17** no. 5, (2013) 975–1076, [arXiv:1112.5179 \[hep-th\]](#).
- [101] O. Aharony, S. S. Razamat, N. Seiberg, and B. Willett, “3d dualities from 4d dualities,” *JHEP* **07** (2013) 149, [arXiv:1305.3924 \[hep-th\]](#).
- [102] O. Aharony, S. S. Razamat, N. Seiberg, and B. Willett, “3d dualities from 4d dualities for orthogonal groups,” *JHEP* **08** (2013) 099, [arXiv:1307.0511 \[hep-th\]](#).