

Università degli Studi di Milano - Bicocca
Facoltà di Scienze Matematiche, Fisiche e Naturali
Corso di Dottorato di Ricerca in Biologia

XXIII ciclo



*Negative effects on a bioindicator by electromagnetic field
exposures alone, and in combination with UVC rays*

A.A. 2009/2010

Ph.D. dissertation

Matteo Siculo

Supervisor

Prof. Angela Santagostino

CONTENTS

ABSTRACT	1
1. BIOMONITORING	3
1.1 – Introduction	3
1.2 – Biomarkers	4
1.2.1 – Markers of exposure	5
1.2.2 – Markers of effect	6
1.2.3 – Markers of susceptibility	6
1.2.4 – DNA damage as a biomarker	7
1.2.4.1 – DNA adducts	8
1.2.4.2 – DNA strand breakage	9
1.3 – Bioindicators	10
1.4 – Oligochetes	12
1.4.1 – Coelomocytes	13
1.4.2 – Immune system of earthworms	14
1.4.3 – Toxicology of earthworms	15
2. GENETIC TOXICOLOGY	17
2.1 – Typology of genetic damage	17
2.1.1 – Gene mutations	17
2.1.2 – Chromosome aberrations	17
2.1.3 – Aneuploidy and polyploidy	18
2.2 – Mechanisms of genetic alteration	18
2.2.1 – Ionizing radiation	19
2.2.2 – Ultraviolet radiation	19
2.2.3 – Chemicals	19
2.2.4 – Endogenous agents	19
2.3 – DNA repair	19
3. ELECTROMAGNETIC FIELD CHARACTERISTICS	23
3.1 – Electric field	23
3.2 – Magnetic field	23
3.3 – Maxwell's equations	23
3.3.1 – Solutions of Maxwell equations according to frequency	24
3.4 – Interactions of fields with matter	25
3.4.1 – Electrical properties of biological tissues	26
3.4.2 – Planar absorption	27
3.4.3 – Specific absorption rate (SAR)	28
3.4.4 – Dielectric properties and field-generated force effects	29
3.5 – Human source of radiofrequency-microwave emissions	31
3.6 – Genetic effects of radiofrequency-microwave fields	34
4. AIM OF THE STUDY	39

5. MATERIALS AND METHODS	41
5.1 – Stripline configuration	41
5.2 – Comet assay	45
5.2.1 – Collection of cells	48
5.2.2 – Slide preparation	49
5.2.3 – Electrophoresis	49
5.2.4 – Slide scoring	49
5.3 – Oxidative damage	50
5.3.1 – Modified comet assay for oxidative damage	51
5.4 – UVR genotoxicity	51
5.4.1 – UVC exposure setting	55
5.4.2 – Repair enzyme-T4 Endonuclease V	55
5.4.3 – Modified comet assay for T4 Endonuclease V	57
5.5 – Field exposure	57
6. STATISTICAL ANALYSIS	61
7. RESULTS	63
7.1 – Results from laboratory exposure	63
7.1.1 – 900 MHz electromagnetic field	63
7.1.2 – Repair enzymes – Endonuclease III and FPG	64
7.1.3 – UV rays exposure	69
7.1.4 – Repair enzyme – T4 Endonuclease V	70
7.2 – Results from field exposure	72
8. DISCUSSION	75
9. REFERENCES	81

ABSTRACT

Genotoxic effects of radiofrequency (RF)/microwave (MW) electromagnetic fields, by using standard protocol of single cell gel electrophoresis (SCGE) or comet assay, were investigated in the coelomocytes of the bioindicator *Eisenia fetida* exposed to both laboratory and field experiments. In particular, laboratory treatments were performed by a TEM microstrip (900MHz – 0.20mW/Kg) to reproduce the characteristics of the waves generated by RF anthropic sources found on field. In order to assess the potential oxidative damage caused by microwave electromagnetic exposure, two base excision repair enzymes, i.e. endonuclease III (Endo III) and formamidopyrimidine DNA glycosylase (FPG) were used in combination with a modified comet assay protocol.

In addition, DNA fragmentation of combinative exposure of ultraviolet rays C (UVC) alone and in combination with microwaves was also studied; in order to assess the influence of electromagnetic fields on DNA repair mechanisms of UVC, T4 endonuclease V (T4PDG) enzyme, which specifically induces single-stranded breaks in ultraviolet-irradiated DNA, was used.

Finally, a fieldwork was conducted in three electromagnetic hot-spots in the city of Milan, Italy; in addition, a negative control site with a low electromagnetic field intensity was considered.

Loss of DNA integrity was detected by using two main comet assay parameters, i.e. Tail Moment (TM) and Tail Moment Olive (TMO). Data showed an initial increase in Δ TM and Δ TMO (expressed as differences between Tail Moment or Tail Moment Olive from exposed and respective controls averages) after EMF treatments, resulting the highest after the first minutes of recovery (Δ TM: 6.63 ± 0.70 , immediately after exposure and Δ TMO: 4.43 ± 0.38 , after 30 minutes, respectively). However, a transient genotoxic damage was observed at 2 hours from exposure ($p < 0.01$). The results, after adding EndoIII and FPG, showed higher values of Δ TM after the combinative treatment with the two repair enzymes compared with microwave exposure ($p < 0.05$) at all times of recovery.

Concerning UVC exposure, we observed the highest value of Δ TM after 1 hour from the exposure (5.94 ± 0.42) and a significant diminish after 2 hours (1.73 ± 0.33). In addition, T4 endonuclease V was able to increase the number of breaks after the exposure to UVC radiation at t_0 , for the damage was approximately four-fold the level of breaks from ultraviolet radiation alone (Δ TM of 3.42 ± 0.36 and 13.88 ± 1.61 , respectively).

The combinative effect of UVC and microwave exposure showed significant lower levels of DNA damage than those of corresponding UVC groups at 1 hour of recovery (3.02 ± 0.26 and 5.91 ± 0.54 , $p < 0.01$ for Δ TM, respectively). However, DNA fragmentation from UVC plus radiofrequency treatments was significantly higher ($p < 0.05$) than those of the corresponding UVC groups for the following times of recovery.

T4PDG did not affect MW-induced DNA breaks ($p > 0.05$); conversely, the action of the repair enzyme was affected by the presence of RF after UV exposure, because Δ TM, after the combinative exposure of the two physical agents, resulted lower than that found by adding T4 Endonuclease V after ultraviolet rays exposure alone ($p < 0.05$).

Finally, field exposures revealed a significant difference between negative controls and exposed animals in all the hot spots ($p < 0.01$); a positive correlation ($p < 0.001$, $R^2 = 0.56$) between electric values and genotoxic parameters was found and no relationship between DNA damage and other environmental parameters, considered under field conditions, was observed

BIOMONITORING

1.1. Introduction

It is a current opinion that a proper monitoring consists of surveillance and:

- 1- A clear identification of the aims and the perspectives of the programme.
- 2- A detection of any changes against predicted standards and/or targets.
- 3- A clear interpretation of the results obtained during the monitoring and understanding the reasons for the gap from the standards.

First of all, a well identification of the aims of a monitoring approach is the point of start of a correct monitoring campaign. In this phase, it is important to clarify the object of the study and to provide a clear indication of what, if any, environmental changes are taking place, by the assessment of "environmental noise". Obviously, the sensitivity and the precision of a monitoring depend on the environmental compartment or the system considered, the goals of the programme and the criteria used during the monitoring (Spellberg, 1991).

Coming to the point two, the standards against which changes are detected may belong to either standards levels guaranteed by norms or to specific natural levels. In such cases, this can be established by comparing the results obtained by our monitoring to those found in control areas, free from the effects of the activity whose results are being monitored. Often, this kind of approach is not suitable and limits have to be established from historical records. Alternatively, control is based on the target of some management actions, such as the recovery of some species following the control of a detrimental pollutant or the holding of a pollutant below some predetermined levels (Furness et al., 1993).

Component number three is fundamental, because if data have been well interpreted, then correct actions can be taken; the key point of this component is to distinguish between natural causes from those sources belonging to human activity. For this reason, information on the fluctuations in the variable are to be measured to discount changes within the normal range.

Holdgate (1979) divided the monitoring approach into two branches: target-monitoring programmes which measure potential or actual targets (i.e. everything that may be liable to show change in distribution or performance) and factor-monitoring programmes which assess everything that may change in the living organisms that underwent a study or the environment they live in. The former approach may involve environmental compartments (air water and terrestrial systems) or biological ones (from ecosystems to individual studies). Factor monitoring is strictly connected with physical variables present in the environment (e.g. temperature, and relative humidity), and chemical variables (for instance, redox compounds and hydrocarbons).

The abovementioned approaches can both be used for biological monitoring, according to the United Nations Conference on Human Environment in Stockholm in 1972:

- Monitoring of factors that influence the environment and identifying the condition of living organisms.
- Assessment of established facts about the condition of the natural environment.
- Prediction and assessment of the condition of the targeted environmental area.

In addition, Samiullah (1990) distinguished between two typologies of biological monitoring by considering environmental and ecological reasons. The first approach is concerned with determining changes in physiological, anatomical and numerical state due to environmental stress, by correlating

concentrations of compounds in the environment with the levels found in living tissues. The ecological approach relies on the estimation of absolute numbers of individuals and the assessment of species composition and the variation in community structure. In conclusion, Samiullah (1990) summed up the concept of biological monitoring by the following: “the measurement, usually repeated, of concentrations of environmental contaminants –thus considering both chemical and physical agents – in living organisms, or as a measurement, either singly or in combination, of such changing genetic, biochemical, physiological and ecological parameters as have been demonstrated by research to be influenced by measured contaminant concentrations”.

1.2. Biomarkers

A correct monitoring is made possible when a strong information on the mechanisms of action and the toxicokinetic of xenobiotics are known; in addition, a whatever biological parameter, and specifically, a variation of this parameter can be used as an index of exposure, if the relationship between the external exposure and the internal dose are clearly identified (Gil and Pla, 2001). But, only when a precise quantification of the index of exposure and the relationship between the internal dose and adverse effect have been detected, then a correct health risk assessment will be performed. For this reason, one of the methods to quantitatively identify the interactions between chemical and physical agents and their potential impact on living organisms is assured by using biomarkers.

According to The National Academy of Sciences ENTOX/TIWET (The Faculty of the Department of Environmental Toxicology and The Institute of Wildlife and Environmental Toxicology, Clemson University, 1996) a biomarker or a biological marker is “a xenobiotically induced alteration in cellular or biochemical components or processes, structures or functions that is measurable in a biological system or sample”. Moreover, a biomarker is also defined as “physiological signals that reflect exposure, early cellular response or inherent or acquired susceptibilities, which provide a new strategy for resolving some toxicological problems” (Silbergeld and Davis, 1994). Adams (1990) little modified the main definition of biomarker including those alterations detected in organism, populations, or communities that respond in measurable ways to changes in the environment. In addition, Depledge (1994) added the concept of behavioural responses, thus including latency and genetic diversity.

The uses of biomarkers as a potential tool for risk assessment have dramatically increased in the last decades, and they are particularly useful in the evaluation of progressive diseases that manifest their symptoms long after the exposure to initiating factors.

An ideal biomarker is characterized by (Gil and Pla, 2001):

- 1- Ease of sample collection and analysis.
- 2- Specificity for a particular kind of exposure.
- 3- Response to a subclinical and reversible alteration.

Points 1 and 3 are well understandable if we consider the definition of a biomarker; the first point is a practical issue, while the last point derives from the intrinsic mean of biomarker. For this reason, biomarkers are useful for their potentially early and predictive response. Concerning point 2, biomarkers range from very specific ones, such as aminolevulinic acid dehydratase (ALAD), an enzyme of the haeme pathway, which is inhibited only by lead, to those non-specific biomarkers, as visualized in table 1.

Biomonitoring

Biomarker	Xenobiotic
Inhibition of ALAD Inhibition of AChE	Lead Organophosphorus compounds and carbamates
Induction of metallothionein Eggshell thinning Porphyrin	Metals (cadmium) DDT, DDE, Dicofol Organochlorine compounds (OCs)
Heat shock proteins Immune response	Metals and OCs Metals, OCs and polycyclic aromatic hydrocarbons (PAHs)
DNA and haemoglobin adducts	PAHs, nitrosamine, aromatic amines, chemotherapeutic agents

Table 1. Some examples of biomarkers listed in order of decreasing specificity of xenobiotics (from Walker et al., 1996).

The Committee of The National Academy of Sciences also disposed a primary classification of biomarkers to determine:

- 1- Internal dose or biologically active concentration, i.e. exposure.
- 2- Adverse effects.
- 3- Susceptible populations or individuals in order to predict a clinical disease (Schlenk, 1999).

Nevertheless, as a great number of biomarkers have been developed in recent years, an overlapping of them has been eventually proposed; in fact, an effect resulting from stressor exposure may be defined as a early non-pathogenic event or more serious and deleterious events, depending on several variables, among which toxicokinetics and the mechanisms of action of the anthropic stressors (Figure 1) (DeCaprio, 1997).

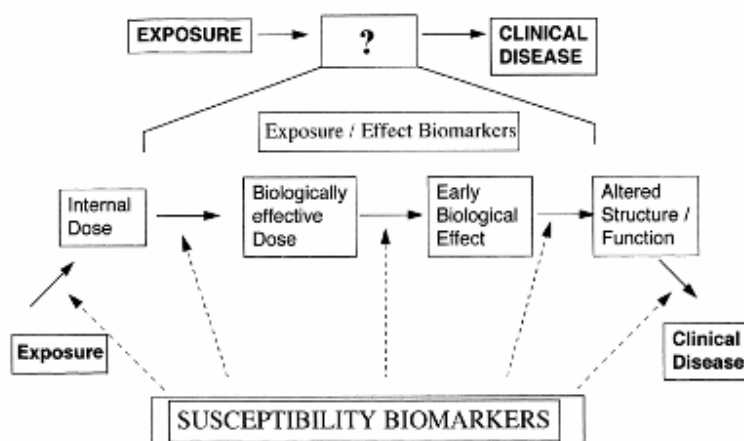

Figure 1. Paradigm tree of biomarker classes (from Schlenk, 1999).

1.2.1. Markers of exposure

The main goal of this kind of biomarker is to evaluate the internal dose or, in some cases, the biologically active concentration in the target. In fact, for the complexities of the transformations of compounds and the tangled interactions involving multicellular organisms, analytical approaches

cannot provide a precise quantitation of bioavailability of a specific compound or a class of xenobiotics. Nevertheless, if the levels of the compound that arrives at the final target can be measured, then a “biologically effective dose” can be detected. A great limitation of this type of biomarker is the oversimplification of the exposure system; in fact, markers of exposure can be easily studied by performing laboratory studies, considering a spectrum of xenobiotic concentrations and assessing the connection between dose and response. On the other hand, animals are exposed to a mixture of chemical and physical agents in the field and this dramatically influences the responses of the markers chosen for the study.

A typical example of markers of exposure is the enzyme Cytochrome P450 1A (CYP1A) monooxygenase induction after exposure to planar aromatic hydrocarbons (Bucheli and Fent, 1995). The induction of specific DNA-adducts by PAHs compounds is another example of markers of exposure (Shugart et al., 1992). The main advantage of this category of biomarkers is the cost-effectiveness, but in some cases this is not true; although the assessment of biological markers can be less expensive than performing complicated chemical analyses, nevertheless, some markers may be not specific for particular compounds and other xenobiotics may induce the same marker. For this reason, the complex mixture of environmental agents present in the field can make the measurement of these markers inadequate.

1.2.2. Markers of effect

The basis of markers of effect is founded on the hypothesis that the effects of stress (directly resulting from stressor exposures or as a consequence of indirect stressors, such as disruption in energy availability, storage or development) are typically evident at lower levels of biological organization before imminent consequences can result in higher levels, like population community or ecosystem (Adams, 1990). The initial responses are evident in the cellular organization and, if the cellular defensive systems fail, higher levels of damage occur, eventually causing histological or physiological impairment, which may be irreversible. Finally, if these processes occur during vulnerable periods of the organism, changes in population or within higher levels of organization may occur (Schlenk, 1999). In many cases, the use of a biomarker alone is not sufficient to characterize the exposure to a specific stressor. For example, some enzymes released into the blood upon tissue damages, such as various hepatic amino acid transaminases, are indicative of a liver damage (Mayer et al., 1992); nevertheless, the addition of other biomarkers, such as those for lipid peroxidation and/or for oxidative stress can lead to an insightful study into the mechanism of the original damage. Finally, the multidisciplinary approach by integrating a suite of markers of effect and other disciplines, like specific chemical analyses, can be very useful to determine a cause-effect relationship, in an accurate way (Collier et al., 1996).

1.2.3. Markers of susceptibility

For the two previous biomarkers, a homogenous response of all assayed individuals is hypothesized, regardless gender or size or development stage. However, many biomarkers are under endocrine control and other environmental factors can influence the response of an individual to a stressor. For this reason, a third category of biomarkers, the markers of susceptibility, can provide a characterization of variability which can be used in defining uncertainty variables, rather than representing stages along the dose-effect continuum (Barrett et al. 1997). As it was said before, intrinsic properties of an organism can influence susceptibility, such as mutations in genes involved in predisposition to specific diseases.

Nevertheless, environmental variables can also affect susceptibility, like previous exposure of an individual to an environmental agent and the physiological condition of an organism.

1.2.4. DNA damage as a biomarker

DNA is the carrier of inherited information and unprogrammed alteration, or modifications in the structure of the molecule can lead to dramatic effects; in addition, some chemical and physical agents are demonstrated to be genotoxicants, for they have the capacity to interact with DNA and often produce adverse and irreversible effects (Shugart, 1998). For this reason, the specific structure of DNA damage can be considered as a biomarker of exposure, and, conversely, the detection of any following and related event occurring after the interaction between the genotoxicant agent and the molecule of DNA can be considered as a biomarker of effect, as well (Shugart et al., 1992). The exposure of an individual to whatsoever genotoxic agent can lead to structural modifications to DNA (Table 2) and may alter the normal cellular processes.

Genotoxicant	Type of modification	Mechanism
Physical	Thymine-Thymine Dimer	Dimerization of Pyrimidine Bases by UV-B Light
	Strand Breakage	Formation of Free Radicals by Ionizing Radiation
Chemical	Adduct	Covalent Attachment of Genotoxicant
	Altered Bases	Chemical Modification of Existing Bases
	Abasic Site	Loss of Chemically Unstable Adduct or Damaged Base
	Strand Breaks	Breakage of Phosphodiester Linkages due to Formation of Free Radicals and Abasic Sites
	Hypomethylated DNA	Interference with Postreplication
	Mutation	Interference with DNA Repair

Table 2. Some structural modifications to the DNA molecule caused by physical and chemical agents (from Shugart, 2002).

Two categories of structural modifications on DNA can be described (Shugart, 2002). First, there are those structural modifications which characterize the genotoxic agent. Ultraviolet light does not directly generate breakage on DNA, but causes specific alterations called pyrimidine dimers; furthermore, some organic compounds, such as polycyclic aromatic compounds (PAHs) can interact with DNA by forming covalent bonds called adducts. In addition to those biomarkers, biological markers to characterize the possible consequences on biochemical processes and effects on DNA after electromagnetic fields exposure have been proposed, in the last years. For example, Goodman and Blank (2002) demonstrated that low frequency (<300Hz) fields induce biological changes, by increasing enzyme reaction rates and an augment in transcript levels for specific genes. As a main result of their studies, they observed the induction of stress protein hsp70 as a valuable tool for the assessment of science-based safety standards for anthropic sources of electromagnetic fields. In addition, Xu et al. (2010) proposed 8-hydroxy-2'-deoxyguanosine (8-OHdG), a typical biomarker used to assess oxidative stress, as a biomarker of DNA oxidative damage for the assessment of genotoxicity of cultured cortical neurons after 1800MHz radiofrequency fields exposure.

The second group of structural modifications is characterized by those agents that suggest the potential for genotoxic exposure, although not very specific. Many agents can interfere with DNA by causing breakages to the single and the double strand; indeed, free radicals or abasic sites generated by genotoxicants can result in the breaks of the phosphodiester linkages within the strands of DNA. So, the potential for genotoxic exposure is connected with an excess of non-specific modifications (strand breaks, apurinic and apirimidinic sites) with respect to negative controls. The following descriptions report some examples from the two categories of structural modifications, in particular, DNA adducts and DNA strand breakages.

1.2.4.1. DNA adducts

Many environmental chemicals affect the health of organisms by producing covalent binding with important molecular receptors. For example, organophosphoric compounds and chemical carcinogenesis generate covalent bindings with a specific protein (cholinesterase) and DNA, respectively (Qu et al., 1997). In the second case, the product of reaction between DNA and the xenobiotic is termed DNA adduct. Currently, methods of a wide range of sensitivity are available to quantitatively characterize DNA adducts; the most reliable technique is ³²P-postlabelling, whose applications are summarised in table 3.

Environment/contaminant	Species	Reference
Freshwater Stream (US)/ Sediment-bound PAHs	Catfish	Dunn et al., 1987
Freshwater Stream (Europe)/ Complex Industrial Waste	Various Fish Species	Kurelec et al., 1989
Marine (Adriatic)/ Complex Industrial Waste	Mussel Carp	Kurelec et al., 1990; Kurelec et al., 1992
Marine Harbor (US)/ PAHs & Complex Industrial Waste	English Sole & Winter Flounder	Varanasi et al., 1989; French et al., 1996
Marine (Canada)/Organics & PAHs	Beluga Whale	Ray et al., 1991
Estuarine River (US)/ Complex Industrial Waste	Muskrats	Halbrook et al., 1992
Marine Harbor (Europe)/ PAHs & Complex Industrial Waste	Eel	van Schooten et al., 1995
Estuarine River (Canada)/ Complex Industrial Waste	White Sucker Fish	El-Adlouni et al., 1995
Terrestrial/PAH-Contaminated Soil	Earth Worm	Walsh et al., 1995
Laboratory/Chlorinated Pesticides	Cells in Culture	Dubois et al., 1997
Marine (Mediterranean)/Industrial & Agricultural Pollution	Mullet	Karakoc et al., 1997
Freshwater Stream (US) Complex Industrial Waste	Catfish	Eufemia et al., 1997
Laboratory/Specific Carcinogen	Mussels	Canova et al., 1998
Laboratory/Specific Carcinogen	Trout/Flatfish	Mitchelmore et al., 1998
Marine Harbor (Europe)/ Complex Industrial Waste	Eel	van der Oost et al., 1999
Stream (Europe)/Wood Preservative	Perch	Ericson et al., 1999
Coastal Waters (Orient)/PAHs	Mussels	Xu et al., 1999

Table 3. DNA adducts assessment using ³²P-postlabelling technique (from Shugart, 2002).

In addition to direct formation of adducts, genotoxic agents can affect DNA with other kinds of damage; free radicals, like the superoxide ion and hydroxyl radicals, belonging to the wide category of reactive oxygen species (ROS), can lead to the oxidation of bases of DNA, in particular purine bases. In addition, the metabolism of certain genotoxicants can lead to oxyradical generation and subsequent oxidative stress in biological systems (Di Giulio et al. 1989). Guanine can be altered by hydroxylation to form 8-hydroxydeoxyguanosine (8-OH-dGuo) and ring opening to form the 2,6-di-amino-4-hydroxy-5-formamidopyrimidine moiety (FapyGua) (Shugart, 2002).

Biomonitoring

1.2.4.2. DNA strand breakage

This kind of damage on DNA is not uncommon, because thousands of breaks per cells per day may occur by many genotoxic agents; however, they can be rapidly repaired and normal conditions are established. Direct breaks on DNA can be caused by the exposure to specific genotoxic agents, like ionizing radiations or free radicals as well, or indirectly. Indeed, after UV rays exposure, photoproducts and pyrimidine dimers are produced by the nucleotide excision repair (NER), which produces DNA breaks as intermediates (Sinha and Häder, 2002). Many assays performed for DNA strand breaks detections are based on the assumption that, at high pH denaturation conditions, the amount of single strand breaks is proportional to the number of strand breaks in the DNA molecule (Rydberg, 1975). According to this assumption, most of the present techniques to quantify the damage on DNA in terms of strand breaks are based on the physical separation of single from double stranded DNA during the denaturation process (Shugart, 2002) (Table 4). Alkaline unwinding assay permits to obtain both single and double strand at the end of denaturation step; for this reason, an additional step to measure single-stranded in the presence of double-stranded DNA is required. Gel electrophoresis is a quite recent technique which is used to identify both single and double strand breaks, under alkaline conditions. DNA migrates under an electric field on agarose gels size-dependant and, finally, the detection is guaranteed by a fluorescent stain.

Finally, comet assay, or single cell gel electrophoresis (SCGE) is a suitable application of the former technique, in which the cell itself is embedded in agarose gels and undergoes electrophoresis (Singh et al., 1988); this assay permits to detect different levels of DNA strand breaks, for the DNA breaks are visible as “comets” with a tail intensity proportional to the dose of the toxicant.

Assay	Organism	Reference
Alkaline Elution	Marine Mussel	Bihari et al., 1990
	Sponge	Batel et al., 1993
DNA Precipitation	Animal Cells	Olive, 1988
Alkaline Unwinding	Sunfish	Shugart, 1988; 1990c; Theodorakis et al., 1992
	Rodents	Morris and Shertzer, 1985
	Turtles	Meyers-Schone et al., 1993
	Marine Mussel	Nacci and Jackim, 1989
	Largemouth Bass	Sugg et al., 1995
	Freshwater Mussel	Black et al., 1996
	Catfish	Sugg et al., 1996
	Marine Seastar	Everaarts et al., 1998
	Catfish	McFarland et al., 1999
	Sponge	Schroder et al., 1999
Electrophoresis Agarose	Sunfish	Theodorakis et al., 1994
	Mosquitofish	Theodorakis et al., 1997
	Mouse	Husby and McBee, 1999
	Fathead Minnow	Choi et al., 2000
Comet Assay	Lymphocytes	Singh et al., 1988
	Animal Cells	Olive et al., 1992
	Brown Trout	Mitchelmore and Chipman, 1998
	Marine Mussel	Mitchelmore et al., 1998
	Marine Mussel	Steinert et al., 1998
	Marine Mussel	Wilson et al., 1998
	Fungi	Hahn and Hock, 1999

Table 4. Applications of different typologies of DNA strand breaks assays (from Shugart, 2002).

Finally, another consideration can be argued; first of all, it has to be considered that, upon the exposure to a genotoxicant, a suite of temporal biological responses may be expressed (Table 5). For this reason,

Biomonitoring

many cellular consequences can be only transient (Shugart, 2002). In fact, the persistence of damage depends of factors such as the dose of the toxicant, or the time of exposure. In addition, other events after the main damage on DNA may occur, and the induction of detoxification processes or the presence of mechanism of DNA repair take place. For this reason, events of detoxication or repair mechanisms can be considered biomarkers of exposure, as well.

Biological response	Expression in cell	Temporal occurrence ^a
Detoxication	Induction of P ₄₅₀ enzyme system	Early
DNA Structural Modification		
Adduct	Covalent attachment of genotoxicant to DNA	Early
Strand breaks	Breakage of DNA phosphodiester linkages	Early
Base Modification	Hypomethylation and chemical modification of bases	Early/Middle
Repair	Induction of DNA repair enzymes	Early
Abnormal DNA	Apoptosis Chromosomal aberrations, micronuclei, aneuploidy	Early/Middle Middle/Late
Pathological Conditions	Neoplasia, tumors, and protein dysfunction	Late

Table 5. Biological responses after exposure to genetic agents (from Shugart, 2002).

1.3. Bioindicators

By considering a pragmatic approach for bioindicators, three groups can be identified.

Test organisms permit to quantitatively determine the ecological effects of industrial chemicals. Individual species represent a middle-level of biological organization between subcellular functions and ecosystems (Fränzle, 2006). Many single-species tests, ranging from bacteria to mammals, alone or in combination within batteries of toxicity tests, have been well correlated with actual chemical impacts (Verschuren, 1983).

Other two groups of bioindicators have been individuated, i.e. the *effect (or reaction) and the accumulation indicators* (Fränzle, 2006). The first one is characterized to quickly respond to physical and chemical stresses (defined as the state of a biotic or an abiotic system under conditions of a “force” applied) (Csermely, 1998), and for this reason, the effect indicators should be low-resistance systems with low adaptive potential.

Biomonitoring

On the other hand, the accumulation indicators are characterised by a great amount of strain (defined as the response to the stress, i.e. the expression before damage occurs), which potentially permits them to accumulate it for a considerable time. Both the types of bioindicators include a wide spectrum of individuals, ranging from subcellular levels to ecosystems whose stress responses generally increase with the complexity of the considered system (Figure 2).

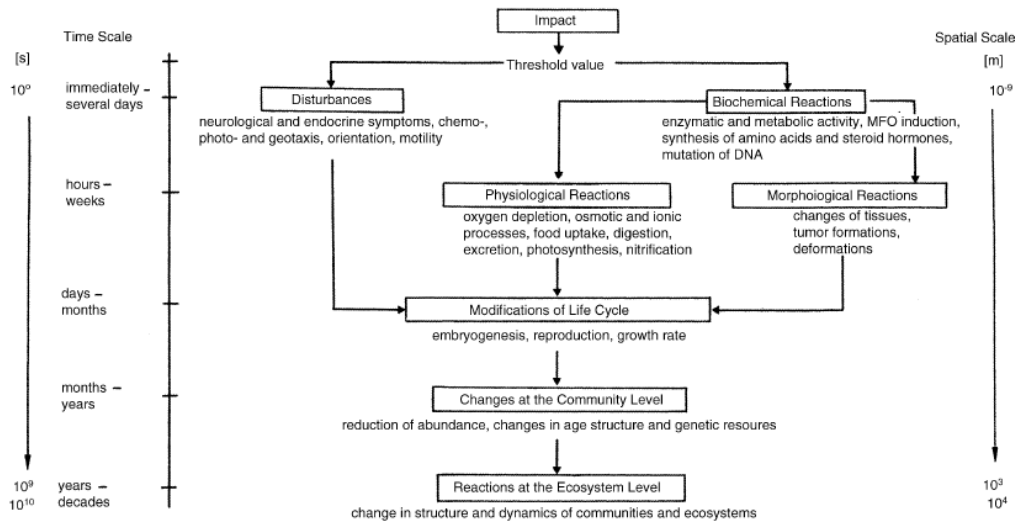

Figure 2. Average stress response times of biosystems with compared to the complexity of the size and the structure of the system (modified from Korte, 1987).

Finally, a division between *active and passive bioindicators* can be done. Active bioindicators are those biological organisms, cells or organelles that are intentionally exposed to physical or chemical agents for a well-defined interval of time. They are characterized by the possibility to cover a wide range of biological processes and they permit rigid geostatistical controls when developing defined areas of interest (Fränzle, 2006).

Passive bioindication is based on the comparative approach by evaluating the responses of those specific components of the existing biocenoses and ecosystems present in the area of study. The immanent advantage of this approach is the possibility to monitor the temporal evolution of the ecosystem of a defined area and to evaluate the actual conditions of that enclosure.

By considering animals as bioindicators, they are characterized by two important properties: first of all, they have developed a great store of stress-coping mechanisms, and non-sessile individuals are able to avoid a great amount of stressors by using their mobility (Fränzle, 2006). For this reason, it is a great challenge to quantitatively determine an individual stressor under field conditions (Iwama, 1998) and to find cause-effect relationships between chemical-physical agents and animals assayed; in fact, environmental matrices are contaminated by a mixture of contaminants with different potential toxicity and that can interact one another with different molecular mechanisms.

Finally, we can define bioindicators at different biological stages, from organelles to organisms and groups of organisms to qualitatively and quantitatively assess the state of the environment, by quickly responding to human stressors without disclosing cause-effect relationship. Summing up some peculiarities of bioindicators we can describe the following points:

- 1- The main task of biological indicators is the general determination of biological effects caused by any stressor, rather than the evaluation of the concentrations of the stressor alone; in fact, it is very difficult to find a quantitative causal interrelationship because of the great amount of anthropic stressors present in the environment, the complexity of pathways and the various

interactions (synergistic and antagonistic) among the agents. Many species with many different characteristics, such as age classes and variations in physical condition will likely differently respond to environmental concentrations/doses of chemical and physical agents, in the ecosystems. Furthermore, complicated interactions among various environmental agents may take place and a high recalcitrance of some chemicals can accumulate in the environmental compartments; finally, the bioavailability of potential toxic compounds may be different, by comparing field conditions and standardized laboratory conditions (Spurgeon and Hopkin, 1995).

- 2- An undoubted advantage is the relative low costs of field biomonitoring approaches with compared to laboratory tests; in addition, the combinative results from passive and active bioindicators can reflect the huge and global state on the investigated area within the total exposure time.
- 3- The extrapolation of data from a single or a test population to estimate the ecological significance of a change, an increase or a diminish, of a measured variable is a great challenge, even if a set of battery tests, by using organisms from different taxa, is proposed.

In this context, an attempt to study a biological indicator for the detection and the quantification of DNA damages caused by electromagnetic fields was done. In particular, we used the versatile indicator oligochete *Eisenia fetida* (Anellidae) for our purposes.

1.4. Oligochetes

Oligochetes are members of the Phylum Anellida, are segmented protostomes, with a well developed blood vascular system and separate cavity called coelom. Coelom is a fluid-filled cavity, lined with squamous epithelium, which lies between the intestine and the muscular body wall. This cavity is surrounded on the outer side by the peritoneum of the body wall and on the inner side by the peritoneum covering the alimentary canal; transverse septa divide it into segmental portions. The peritoneum covering these septa is similar in structure to that covering the inner surface of the muscle layers.

Septa usually correspond to the external segmental grooves but do not often occur in the first few segments of the body and, they are missing in other parts, in some cases. Two adjacent septa are sometimes fused at their junction with the body wall. Septa differ in thickness, depending on their position in the body, those in the anterior of the body being markedly thickened and more muscular. The degree of thickening, and the position and the number of these septa are used as systemic features by many species of earthworms. Septa are formed from muscle fibres, mostly derived from longitudinal muscle layer, together with some circular muscles on the posterior face, with connecting tissue and blood vessels. Septa are perforated by pores which allow the coelomic fluid to pass freely through the segments. There are also bands and sheets of mesenteric membranes between the body wall and the gut, forming pouches.

The coelomic fluid is a milky white liquid, which is sometimes coloured yellow by leucocytes, cells containing oil droplets. In addition, the coelomic fluid of the species *E.fetida* smells of garlic, hence the name of the species. This fluid contains many different kinds of particles in suspension; the inorganic inclusions are mainly crystals of calcium carbonate, but the corpuscular bodies in the coelomic fluid of lumbricid worms include phagocytic amoebocytes, feeding on waste materials and vacuolar lymphocytes (small disk-shaped bodies). Other inclusions in the coelomic fluid comprise breakdown products of the corpuscular bodies, protozoan and nematode parasites, and bacteria. The so-called "brown bodies" results from an aggregation of masses or nodules consisting in bacteria, gregarines,

incompatible grafts fragments and altered self structures such as setae or necrotic muscle cells. The initial nodule rapidly increases in volume by aggregation of new coelomocytes and various waste particles. When a brown body has reached a diameter of 1-2mm, its external cells flatten and lose their adhesiveness toward free coelomocytes or waste particles and its pigment rapidly darkens. Earthworms eject coelomic fluid through the dorsal pores, in response to mechanical or chemical irritation, or when subjected to extremes of heat or cold.

1.4.1. Coelomocytes

Coelomocytes of Oligochetes are characterized by a strong polymorphism and their qualitative and quantitative composition depends on many variables, such as individual age, physiological and environmental conditions (Avel, 1959). There have been many attempts to classify the coelomocytes of earthworms, univocally; nevertheless, the lack of a uniform classification system results from the fact the coelomic fluid contains cells at various functional states and different stages of maturation. For example, Stein et al. (1977) observed three kinds of cells in *Lumbricus Terrestris*: hyaline amoebocytes, granular amoebocytes and eleocytes. Nevertheless, Jarosz and Glinski (1997), distinguished eleocytes, called also chloragogenic cells, into type I and type II eleocytes.

Finally, Valembois (1973) and other authors (Valembois et al., 1992) divided coelomocytes of *E.fetida* into two groups, each divided into subgroups. For this reason, the main grouping of cells found in *E.fetida* consists in eleocytes, amoebocytes and granulocytes (Figure 3).

Eleocytes originate from chloragogenic tissue surrounding the intestine (Affar et al., 1998) and are present in all earthworms. They constitute approximately 30% population of circulating cells in coelom cavity; they are round shaped with a surface area of $1770\mu\text{m}^2$. They have small, spherical nuclei, located eccentrically. In *E.fetida* this kind of cells is capable of storing nutritive substances, such as glycogen and lipids (Roots and Johnston, 1966), rather than taking part in immune processes, like in many other lumbricids occurs. Nevertheless, chloragocytes, from which eleocytes derive, have been found being responsible for maintaining constant pH and the regulation of ionic balance (Prentø, 1994), and the formation of brown bodies, in *E.fetida* (Valembois et al., 1992).

The second types of cell, the amoebocytes, constitute about 40% of coelomocytes; they have centrally or peripherally located nuclei, whose shape varies from oval to kidney-like (Adamowicz and Wojtaszek, 2001). In *E.fetida* two sub-groups can be distinguished: amoebocytes I and II. The first category, called also leucocytic cells, is characterised by a form of short lobopodia and plays an important role during phagocytosis (Stang-Voss, 1971). Amoebocytes II, or lymphocytic cells participate during immune reactions, such as nodulation (Valembois et al., 1992) and graft rejection (Parry, 1975). In natural conditions, earthworms undergo a great variety of exogenous and potentially toxic substances, which may affect the body cavity and cause damage and infection. When the infection occurs, it is inactivated through non-specific defensive reactions, among with phagocytosis, encapsulation and nodulation. In particular, the mechanism of the first process is a multiphase reaction, where the mechanisms start after immunological recognition, effected by specialized cells which are able to distinguish the endogenous components from alien substances. The following stages of phagocytosis are chemotaxis and adhesion; in anellids the factors aiding to the process may include agglutinins and components of activated prophenoloxidase system (Cooper, 1996). Subsequently, a phagolysosome is formed in which a final, enzymatic destruction of biotic factor occurs (Affar et al., 1998).

The third type of coelomocytes found in *E.fetida*, the granulocytes, constitute approximately 30% of total coelomocytes (Adamowicz and Wojtaszek, 2001). They are spherical of a mean area of $180\mu\text{m}^2$. They have spherical, centrally located nuclei, rich of organelles and of electron dense cytoplasmatic

granules. These cells can degranulate the compounds into extracellular space, where they are, then, located in the coelomic fluid (Adamowicz, 2005).

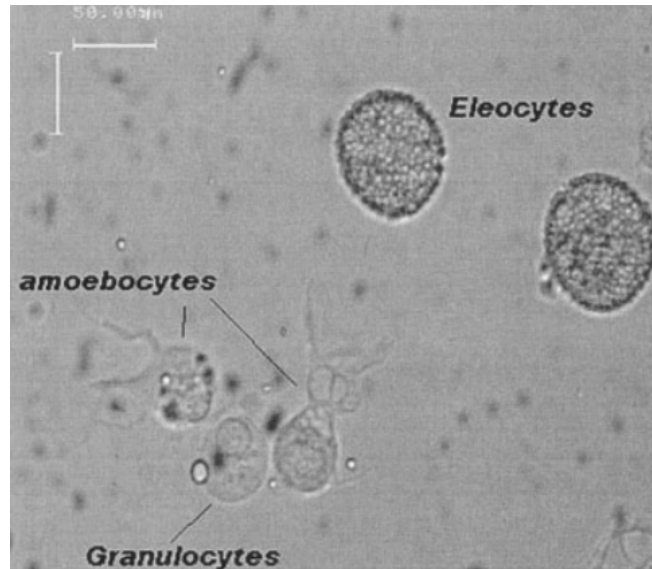

Figure 3. Eleocytes, amoebocytes and granulocytes of *E.fetida*. (from Di Marzio et al., 2005).

1.4.2. Immune system of earthworms

Numerous invertebrate species have been used to assess environmental risks, usually by exposing to neat chemicals, chemicals mixtures or solid matrices, but, they have been recently proposed as a surrogate species (Burch et al., 1999). In fact, the development of assays by using invertebrate surrogates in place of vertebrates species for studying risk assessment of toxic agents to environment and human health has become a relevant issue of public concern (Burch et al., 1999).

For this reason, a suite of biomarkers, among which the process of phagocytosis by immunoactive cells from coelome and their viability, has been considered one of the most promising and suitable tool as surrogate assays to study immunotoxic risk to higher wildlife, including mammals.

The invertebrate immune system is innate, natural, non-specific, non-anticipatory, and non-clonal; on the other hand, the vertebrate adaptive immune system is induced, specific, anticipatory, and clonal; however, some authors (Cooper, 2003; Šíma and Větvička, 1990) affirm that the immune system of invertebrates represents, in a sense, the precursor of the immune system of vertebrates.

Invertebrate immunocyte receptors may be connected to the common agglutinins and lectins which are contained into the leukocytes of celomic cavity (Cooper, 1996). Although a univocal opinion has not been found among immunologists, for some consider homology as a “trap” and the concept of functional similarity is excluded from the definition of homology because it so often develops independently during evolution (Klein, 1997), nevertheless many immunologists believe that invertebrates are the precursor of all known vertebrate immunocytes (Burnet, 1968) and the coelomic fluid is compared with to vertebrate blood carrying immune cells (Cooper, 2003). The process of phagocytosis, brown body formation, graft rejection and NK-like activity are the most relevant cellular immune reactions in earthworms connected with the action of coelomocytes, and some of these routes, like NK-like activity and pore formation resemble functionally perforin and/or complement of vertebrates (Cooper, 2003).

1.4.3. Toxicology of earthworms

Earthworms are often used as valuable test organisms for their biological utility and because of their easy handling and relatively low cost. In fact, earthworms are very important because they are decomposers, and for they can be used as risk primary poisoning interceptors (in fact, they may be directly affected by toxic compounds) or risk secondary tools for predators feeding on earthworms (Karaka, 2010). For this reason, these organisms are considered as a valuable reference to detect soil contaminant bioavailability (Rudd, 1964). Globally, earthworms have an important role in the terrestrial food chain for their sensitivity to particular classes of compounds, like heavy metals and PCBs (Song et al., 2009); therefore, they are considered necessary for the prediction of potential food-chain effects of soil contamination. They are also used as a reliable tool within ecotoxicological battery tests in order to assess the toxicity of new developed compounds by using well-developed and standardized protocols (OECD, 2000). On the contrary, a slight number of studies concerning the biological consequences on earthworms after exposures to physical agents were done. In particular, they dealt with the effects produced by ionizing radiation (Suzuki and Egami, 1983) and UV radiation (Hamman et al., 2003; Misra et al. 2005). These studies have been performed in order to elucidate the physiological and biochemical effects due to both UVA and UVB radiation, due to increase of UVR in sunlight in view of ozone depletion (Babu et al. 1998). The authors found interesting results on the decrease of fecundity of well-developed adults of *E.fetida* and a decrease in the cocoons' fertility of around 70 % (Hamman et al 2003). Moreover, a significant amount of reactive oxygen species (ROS) and photooxidation of lipids in skin homogenate of the earthworm *Metaphire posthuma* were observed, and other histological anomalies, such as thickening, vacuolation and hypertrophy of epidermal cells were found (Misra et al. 2005). Unlike ionizing and UV radiations, a few attempts to study the interaction between biological responses of earthworms and electromagnetic fields have been proposed (Pakhomov et al., 1991; Qi et al., 1995); the aforementioned projects concerned the effects of microwaves on the function of giant nerve fibres in *Lumbricus terrestris*, demonstrating that the focal, directional energy was sufficient to induce anatomical medial giant axon (MGA) severed by crushing with a razor blade fragment (Qi et al., 1995). However, other invertebrate species were widely used to characterize the biological effects caused by the exposures to electromagnetic fields for both extremely low frequencies (50-60Hz) and high-extremely high frequency radiation (3MHz-300GHz). Experiments on Planaria *Dugesia tigrina* demonstrated an increase in heat shock protein 70 (hsp70) levels and a significant increase in regeneration in both head and tail after low frequency field – 60Hz and 80 milliGauss (Goodman et al., 2009); however, it has also to be said that the incidence of regeneration anomalies presenting as tumor-like protuberance in *Dugeisa tigrina* has been observed after exposure to weak 60 Hz magnetic fields, with peak intensities ranging between 1.0 and 80.0 microT (Jenrow et al., 1996).

In addition, some controversial results on honeybees (*Apis mellifera*) were reported in previous studies after exposures to microwave electromagnetic fields. A significant decrease in colony strength and in egg laying rate of the queen was observed, and the behaviour of exposed foragers was negatively affected by GSM 900MHz frequency electromagnetic field (power density 8.549W/m² and 56.8V/m electric field) (Sharma and Kumar, 2010). Nevertheless, Gary and Westerdahl (1981) did not observe any anomalies in flight, orientation, and memory functions on foraging-experienced honeybees after 30 minutes exposure to 2.45-GHz CW microwaves at power densities from 3 to 50mW/cm². In addition, no difference between exposed and sham-controls were evidenced in adult honeybees exposed for 0.5, 6, and 24 hours to 2.45-GHz continuous wave microwave radiation at power densities of 3, 6, 12, 25, and 50mW/cm². However, a low content of glucose in adult honeybees exposed to magnetic fields (7 Tesla) with respect to controls was observed, thus indicating that trehalase enzyme activity was

dramatically reduced in high magnetic fields; moreover, a greater amount of phospholipids was found in the intestines of magnetic field-exposed bees than in control animals (Kefuss et al., 1999).

Biological effects caused by 835MHz frequency exposure in the *Drosophila melanogaster* were observed by Lee et al. (2008); this kind of exposure lead to an increase in the stress response, by an augmentation of reactive oxygen species (ROS). Moreover, the exposure to high frequency electromagnetic field triggered ERK-survival signalling at doses (1.6W/Kg) lower than those causing thermal effects, but the strong electromagnetic radiation (4.0W/Kg) activated JNK-apoptotic signalling and expression of apoptotic genes in *Drosophila*. The exposure to microwave intensities also modified the development in fruit fly (Panagopoulos et al., 2004); signals produced by GSM multiband mobile phone (900-1900MHz, SAR 1.4W/Kg) affected the stage from egg laying through pupation of fruit flies increasing the numbers of offspring, rising hsp70 levels, increasing serum response element (SRE) DNA-binding and inducing the phosphorylation of the nuclear transcription factor, ELK-1, a transcription factor in the MAPK-inase cascade (MAPK pathways consist of distinct cascades of regulator enzymes that serially activate one another to control the expression of specific genes in response to growth factors, cytokines and tumor promoters) (Weisbrot et al., 2003).

On the other hand GSM 900-MHz (Global System for Mobile telecommunications) or DCS1800-MHz (Digital Cellular System) radiation caused a large decrease in the oviposition of fruit fly (Panagopoulos et al., 2007).

Finally, to study the effects of an extremely low frequency 50Hz magnetic field on the oviposition and development of *Drosophila melanogaster* over three generations (parental generation, first filial generation (F1), second filial generation (F2), third filial generation (F3)), researchers assessed the effects on embryo/fetus and on reproductive ability of fruit fly (Gonet et al., 2009). The embryogenesis of these eggs was accelerated (first larvae of the F1 generation developed 24h earlier than the control larvae). However, data showed that exposure of *Drosophila melanogaster* females of parental generation and exposure of all the development stages of the first filial generation weakened the oviposition of these insects in their subsequent unexposed generations F2 and F3.

Non-homogeneous data on biological effects after electromagnetic exposure were collected by performing experiments on the nematode *Caenorhabditis elegans*. Low intensity microwave irradiation (1.0GHz, 0.5W power input; SAR 0.9–3mW/kg) did not significantly alter heat shock reporter gene expression in L4/adult *C.elegans* (Dawe et al., 2009). Moreover, for both continuous wave (CW) and simulated GSM exposure - Talk-pulsed RF exposures – at 1.8W/kg and 1.8GHz, no relevance of induction of transgene expression promoter from a small heat-shock protein (hsp16-1) was found (Dawe et al., 2008). Nevertheless, transgenic nematodes *Caenorhabditis elegans* strain PC72, carrying a stress-inducible reporter gene (*Escherichia coli* β -galactosidase) under the control of a *C.elegans* hsp16 heat shock promoter, was used as a valuable biological marker to evaluate stress responses after microwave radiation. 750MHz irradiation of nematodes caused stress reporter gene induction after 2 and 16 hours, but not after 4 and 8 hours of exposure. On the other hand exposure to 750MHz, but not to 300MHz at different power settings (500, 250, 125mW) for 16 hours caused stress reporter gene induction in nematodes (Daniells et al., 1998). All these studies demonstrate the importance and the complexity of this topic and the controversy of the results present in the scientific literature; hence, the lacking of a uniform judgment on microwave electromagnetic fields prompts the research to go in depth with this issue.

2. GENETIC TOXICOLOGY

Genetic toxicology is defined as that branch of toxicology which focuses on the mutagenic effects of chemical and physical (radiations) agents and the consequences of health of organisms exposed to these sources. For this reason, genetic toxicology is involved in both the study of the mechanisms of mutagenesis and the formulation of means of assessing health risk assessment causes by mutagens. Mutagenesis deals with a wide range of damages on the DNA molecule, such as changes in DNA base pairs (gene mutations) or alterations in the structure of DNA (chromosome aberrations) or number (aneuploidy and polyploidy) (Klaassen, 2001). Furthermore, mutagens can affect both germ and somatic cells. The former action on eggs, sperm and their precursors may have important implications in genetic diseases in the future generations, while the genetic mutations affecting somatic cells may contribute to the genetic diseases of the individual.

2.1. Typology of genetic damage

Three main kinds of genetic damage are widely known: gene mutations, chromosome aberrations and alterations in chromosome number.

2.1.1. *Gene mutations*

These mutations are called point mutations and are changes in the DNA sequence in a gene; they are detected according to the changes on the phenotype, like those occurring in the pigmentation or in the ear length (Ehling, 1991).

Moreover, base-pair substitution occurs when a pair of bases is substituted by another; they are subdivided into two groups: transition, when purine to pyrimidine orientation of the base pair remains the same, and transversion, if a purine is substituted by a pyrimidine and viceversa. Obviously, the consequences depend on whether the substitution leads to a missense or nonsense in the process of protein synthesis. A missense occurs when there is a coding change in which an aminoacid replaces another in the sequence; the final product depends on the specific aminoacid substations and may have no effect, or be a leaky mutation, thus meaning that this mutation only slightly affects the function of the gene or inactivates the gene itself. A nonsense mutation of the triplet codon leads to a premature termination of the protein formation, so the gene is incomplete and non-functional. Finally, frameshifts cause the translation of the genetic code and, as a consequence, the addition and the loss of one or two base pairs. This kind of mutation may cause dramatic alterations because every triplet is changed in the mRNA from the beginning of the mutation and it may also produce an incomplete gene, as a nonsense codon may be formed (UAA, UGA, UAG).

2.1.2. *Chromosome aberrations*

This kind of alterations affects the structure of the DNA molecule and involves the alteration of genetic material; as a result, consequences on structure, like chromosome breakages and chromosomal rearrangements may occur; to be more precise, chromatide-type aberrations involve only one of the two chromatids in a replicated chromosome, while chromosome-type aberrations are those structure alterations concerning both chromatids. For example, ionizing radiations, like X and gamma rays, induce both damages depending on the stage of DNA replication; in fact, chromatid alterations occur after DNA replication, while chromosom alterations occur after the replication of DNA (Klaassen, 2001). In some cases, aberrations, like deletions, duplications, and inversions are stable and can persist in the cell population; moreover, other types of aberrations, deriving from chromosome breaks, lead to acentric fragments, dicentric chromosomes and other rearrangements which are unstable and may cause the loss of genetic material, thus leading to the death of cell.

2.1.3. Aneuploidy and polyploidy

This form of alteration involves the number of chromosomes with compared to the actual set of chromosomes. For example, aneuploidy concerns the adding or the loss of one or few chromosomes; conversely, polyploidy, is characterized by the fact that the entire set of chromosomes is altered. In the human species, those individuals with a number of chromosomes higher or lower than 46 (e.g. 45 or 47) are affected by aneuploidy. On the other hand, those humans with 69 chromosomes are described as affected by polyploidy, triploid, in this case. For example, Down syndrome results in the trysomy 21, i.e. an individual has three copies of chromosome 21.

2.2. Mechanisms of genetic alteration

Many types of damages caused by physical agents (ionizing and non-ionizing radiations) and chemical compounds include breaks to single and double strand of the molecule of DNA, crosslinks between DNA bases and between bases and proteins and adducts to DNA (i.e. chemical addition to the DNA bases); the main kinds of damage on DNA are described in figure 4.

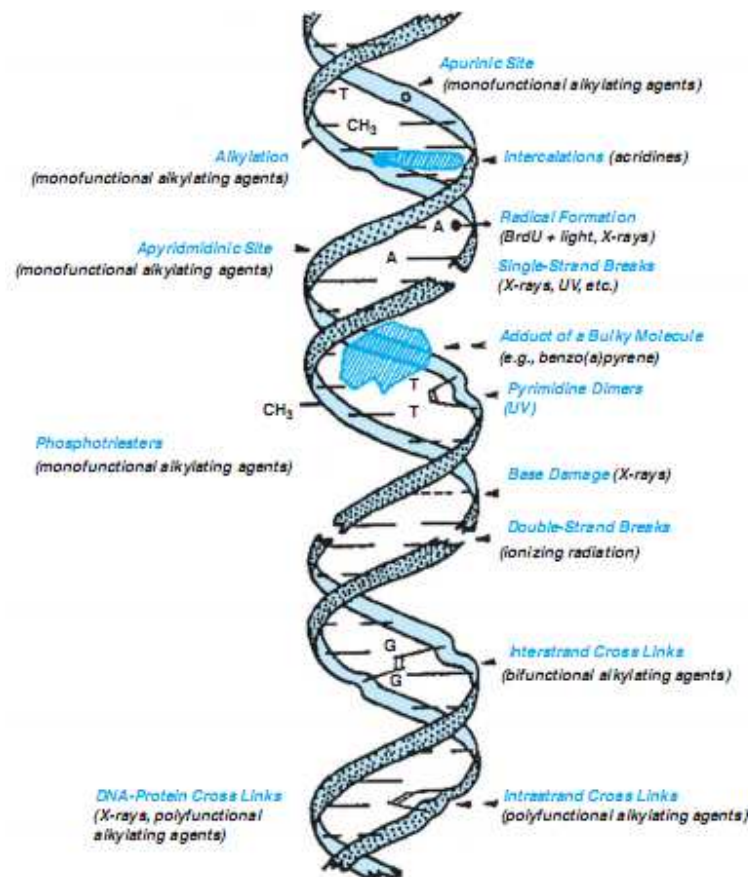

Figure 4. Typologies of DNA damage (from Klaassen, 2001).

It is important to point out that the endogenous and exogenous agents can cause all the damages presented in the spectrum of figure 4; nonetheless, errors in the process of replication and those produced by the mechanisms of DNA repair can be taken into account.

2.2.1. Ionizing radiation

X-rays, alpha and gamma rays can produce a great amount and a wide range of damages on DNA, such as base damages and strand breaks (Ward, 1994). It has been recently ascertained that clustered lesions, and more difficult to repair damages can be formed, such as oxidized purines or pyrimidines and single strand breaks (Blaisdell et al, 2001). The typology of damage mainly depends on the quantity of energy deposited on the test domain; for example X-rays, whose ionization is sparse, produce single-strand breaks, and base damages while alpha rays, which are denser, lead to both single and double strand breaks (Blaisdell et al, 2001).

2.2.2. Ultraviolet radiation

Ultraviolet rays (ranging from 100nm to 400nm) do not form directly strand breaks, rather than two main by-products of damages, i.e. cyclobutane pyrimidine dimers and 6,4-photoproducts (Friedberg et al., 1995).

2.2.3. Chemicals

Direct (adducts) and indirect (intercalation of a chemical between base pairs) alterations to DNA frame can be produced by chemicals; in particular, some alkylated bases can cause mutations when DNA is replicated. For example, the alkyl group of a N7-alkylguanine adduct lyses the bond that links the base to deoxyribose, thus stimulating the loss of the base itself. The product from this step is called apurinic or apyrimidinic site and the insertion of an incorrect base in the lacking site causes mutations (Laval et al., 1990).

2.2.4. Endogenous agents

Most part of the DNA damages caused by endogenous agents consists of altered bases (8-oxoguanine and thymine glycol) and AP (apurinic/apyrimidinic sites) and can be hundreds per cell per day (Lindhal, 1993).

The cellular processes that lead to negative effects on DNA have reference to the formation of reactive oxygen species, such as superoxide ion, or hydroxyl radical and deamination of cytosines and 5-methylcytosines leading to uracils and thymines, respectively (Klaassen, 2001). Finally, errors from DNA replication can be classified within those from endogenous agents, for incorrect bases can be added by replication polymerase.

2.3. DNA repair

When chemical and physical agents interact with DNA, they are not only involved in pairing specificity of altered bases, but they have also strict connections with cellular replication processes and the mechanisms of DNA repair. For example, UV agent does not cause direct breaks on the molecule of DNA, but it produces dimers and photoproducts (Sinha and Häder, 2002), thus blocking replication and causing death of the cell (Friedberg, 1985). Moreover, visual breakages can be detected only after the action of specific DNA repair mechanisms, called nucleotide excision repair system (NER) that turn by-product of UV exposure into breaks. In addition, bulky adducts of the aromatic amide N-2-acetylaminofluorene (AAF) on the position of guanine also negatively influence the replication step (Heflich and Neft, 1994). For this reason, it is important to elaborate the complex interactions between mutagenicity determined by chemical and physical agents and cellular/repair processes.

For DNA is subject to endogenous and exogenous mutations that interfere with normal cellular functioning, it is not surprising that organisms have evolved various mechanisms that cope with spontaneous hydroxylation and methylation of DNA as well as chemical compounds and physical agents that have been present from the beginning of life (Lindhal, 1993). Specifically, if damage is

severe, the cell undergoes apoptosis (programmed cell death), effectively avoiding to determine a mutant cell (Evan and Littlewood, 1998).

If the occurrence of damage is less relevant, processes of repair can take place. These processes can be divided into damage-tolerance and repair mechanisms (Friedberg, 1985). The first process concerns a by-passing step, where the mechanisms entail bypassing a lesion that could lead to block replication. In the recombinational repair present in microorganisms, a gap in the new strand opposite to the damage is left by replication mechanism; finally, the gap is filled with the segment of DNA from the opposite parental strand (Griffiths et al. 1993).

On the other hand, DNA repair mechanisms can be grouped into direct and excision repair (Sancar and Tang, 1993). The first mechanism is based on the principle that DNA damage is reversed and the initial condition is established. Photorepair is a direct mechanism which is active in presence of light and in which the enzyme photolyase cleaves dimers that can form between two adjacent pyrimidines (Thoma, 1999). Another example of direct repair is the reversal of methylation on the O⁶ – position of guanine through the transfer of the methyl group to the protein O⁶-methylguanine-DNA methyltransferase, thus establishing the normal base-pairing condition (Shevell et al., 1990).

The other class of repair, excision mechanisms, is commonly based on the damage recognition, removal of damage (except for cleavage of pyrimidine dimers and strand breaks), and DNA repair synthesis and ligation step. The two most important pathways of excision repair are nucleotide and base excision repair, which are present in both prokaryotes and eukaryotes, though they differ on details.

Nucleotide excision repair is the most common mechanism of repair in all organisms (Hanawalt and Mellon, 1993), including repair from UV photoproducts and bulky chemical adducts and intrastrand cross-links (Holbrook and Fornace, 1991). In the last decade the nucleotide excision repair (NER) has been widely studied and a complete characterization of the genes and proteins involved has been obtained (Reardon and Sancar, 2005). NER uses about 30 proteins to detect and remove the damage; the principles underlying this mechanism of repair consist in damage recognition, removal of damage by incision, excision steps, repair synthesis and ligation step. The first stage starts from the presence of an endonuclease that nicks the DNA backbone in correspondence with the side of damage (Sancar and Tang, 1993); then, a helicase removes the oligonucleotide that contains the damage, leaving a gap of about 27-29 nucleotides in the eukaryotes. Finally, a DNA polymerase fills the gap by adding the lacking sequence of nucleotides, using the opposite strand as a template. The remaining break is guaranteed by DNA ligase.

Base excision repair starts with the presence of a glycosylase that removes the damaged base, thus causing an apurinic/apyrimidinic (AP) site; then, an AP endonuclease cleaves the DNA backbone and removes the deoxyribose to which the damage had been attached (Sung and Demple, 2006). The resulting gap can be filled by a DNA polymerase, followed by a ligation step in which the new sequence is linked with to the parental DNA. DNA glycosylase can remove pyrimidine dimers from UV exposure, nonbulky agents originated by agents such as ionizing radiations, alkylating agents and hydrogen peroxide (Holbrook and Fornace, 1991). Both nucleotide and excision repair processes are briefly described in figure 5.

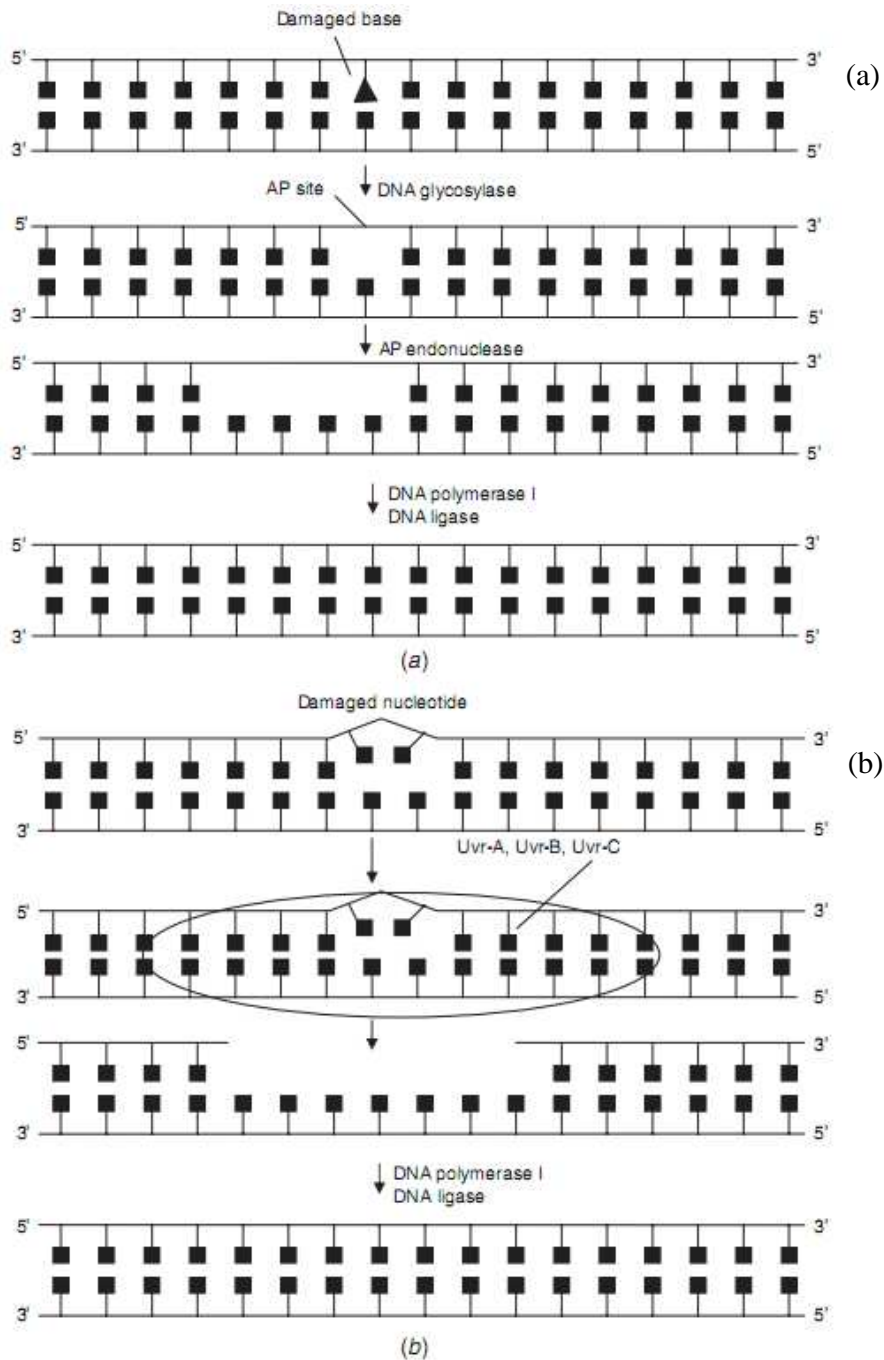

Figure 5. Base excision repair (BER) (a), and nucleotide excision repair (NER) (b) (from Klaassen, 2001).

Mismatch repair is a particular class of excision repair in which incorrect base pairs, such as G:T and A:C are recognized and removed; these kinds of damage arise from errors in DNA replication or genetic recombination or induced by the action of chemical agents, such as N-methyl- N-nitro-N-nitrosoguanidine, an alkylating agent (Jun et al., 2006).

When cell survival is undermined by the presence of broken chromosomes inside the cell itself, a spectrum of mechanisms of repair have been developed to reduce the persistence of this damage.

Homologous and nonhomologous recombination pathways, (HR and NHEJ) respectively, are the most common processes of strand breaks repair (Sonoda et al., 2006).

Homologous recombination plays an important role in normal activities of eukaryote cells in both germ and somatic cells; nevertheless, HR plays a dominant role in any DSB repair in yeast, whereas NHEJ significantly contributes to DSB repair in vertebrates (Sonoda et al., 2006).

The basic steps in double-strand break repair are described below. The initial step is the production of a 3'-ended single-stranded tail by exonucleases or helicase activity. Through a process of strand invasion, whereby the single-stranded tail invades an undamaged homologous DNA molecule, together with DNA synthesis, a so-called Holliday junction DNA complex is formed. By cleavage of this junction, two DNA molecules are produced (with or without a structural crossover), neither of which now contains a strand break (Cahill et al., 2006).

NHEJ pathways consists of end-binding and tethering steps in which a DNA-dependant protein-kinase (DNA-PK) forms a complex with protein Ku, a heterodimer consisting of Ku70 and Ku80 subunits, thus sliding onto the DNA end and translocating inward. DNA-PK complex may serve as a signal molecule for recruiting other repair proteins, functioning as a docking site for other NHEJ proteins (Palmbos et al., 2008). Then, end processing involves removal of damaged or mismatched nucleotides by nucleases and resynthesis by DNA polymerases and finally, the ligation step is performed by DNA ligase IV (Wilson et al., 1997).

3. ELECTROMAGNETIC FIELD CHARACTERISTICS

As this project concerns the possible interactions between DNA and electromagnetic fields, a brief description of the most important variables characterizing this issue, such as electric and magnetic field, near and far field, the specific absorption rate (SAR) and topics connected with electromagnetism will be presented in the following paragraphs, as well. In particular, electric and magnetic properties of living matters and the interaction between tissues and the energy produced by electromagnetic fields will be presented in order to focus on the main issue of this branch of physics and to clear out the studies reported in the following chapters.

3.1. Electric field

The fundamentals of electromagnetism are based on the phenomenon in which electric charges exert forces on each other; so, the mathematical statement of the vector force (\mathbf{F}) on one charge, q_1 , due to the presence of another charge, q_2 , is called Coulomb's law:

$\mathbf{F} = k \frac{q_1 q_2}{\mathbf{d}^2}$, where \mathbf{d} is a vector along a straight line from q_1 to q_2 and pointing toward q_2 . k is a constant called the permittivity of free space, having farads per meter as units. The \mathbf{E} -field is defined when a point test body charged q , is brought into a region of space, where an \mathbf{E} -field vector exists. According to Coulomb's law, the force \mathbf{F} on the test charge is proportional to q . The \mathbf{E} -field is defined as:

$\mathbf{E} = \frac{\mathbf{F}}{q}$. The units of \mathbf{E} are volts per meter. Thus, we could determine whether an \mathbf{E} -field existed at a given point in space by placing a small charge at that point and measuring the force on it.

3.2. Magnetic field

When electric charges are moving, a force in addition to that described by Coulomb's law is exerted on them. We defined another force called the magnetic-flux-density (\mathbf{B} -field) vector, \mathbf{B} , and defined in terms of the force exerted on a small test charge, q . Finally, vector \mathbf{B} is defined as:

$\mathbf{B} = \frac{\mathbf{F}_m}{q\mathbf{v}}$, where \mathbf{F}_m is the maximum force on q in any direction, and \mathbf{v} is the velocity of q . The units of

\mathbf{B} are webers per square meter. The magnetic field is characterized by the fact that the vector \mathbf{F}_m is always perpendicular to both the velocity of moving charge and vector \mathbf{B} by the following:

$$\mathbf{F} = q (\mathbf{v} \times \mathbf{B}).$$

When a moving charge q is placed in a space where both an \mathbf{E} -field and a \mathbf{B} -field exist, there is a strong relationship between electric and magnetic field given by the following:

$$\mathbf{F} = q (\mathbf{E} + \mathbf{v} \times \mathbf{B}),$$
 which is called the Lorentz force equation.

3.3. Maxwell's equations

The following formulas are one of the most important equations' groups of electromagnetism and sum up the most relevant relationships between electric and magnetic field:

$$a) \nabla \times \mathbf{E} = -\partial \mathbf{B} / \partial t$$

$$b) \nabla \times \mathbf{H} = \mathbf{J} + \partial \mathbf{D} / \partial t$$

$$c) \nabla \cdot \mathbf{D} = \rho$$

$$d) \nabla \cdot \mathbf{B} = 0,$$

where

$$\mathbf{B} = \mu \mathbf{H}.$$

$$\mathbf{D} = \varepsilon \mathbf{E}.$$

\mathbf{J} is the free-current density in A/m^2 .

ρ is the free-charge density in C/m^3 .

∂ stands for a mathematical operation involving partial derivatives, called the curl.

∇ stands for another mathematical operation involving partial derivatives, called the divergence.

From the first equation called Faraday's law, it can be argued that a time-varying \mathbf{B} -field produces an \mathbf{E} -field, and the relationship is such that the \mathbf{E} -field lines so produced tend to encircle the \mathbf{B} -field lines; the second equation states that both current density and a time-varying \mathbf{E} -field produce a \mathbf{B} -field; in this case, the magnetic field lines tend to encircle the current density and the \mathbf{E} -field lines. The following equation states that charge density produces an \mathbf{E} -field, and the \mathbf{E} -field lines produced by charges begin and end on those charges; finally, according to the last equation of the group, no sources are related to the divergence of the \mathbf{B} -field. This means that the \mathbf{B} -field lines always exist in closed loops.

3.3.1. Solutions of Maxwell's equations according to frequency

The equations of Maxwell have a wide range of use and can be applied to both static fields and frequency-dependant fields. Consequently, special techniques have been developed for several ranges of the frequency spectrum. The special techniques depend on the relationship between wavelength and the nominal size of the system to which Maxwell's equations are applied. Three main categories can be identified as the following description:

$\lambda \gg L$, electric circuit theory (Kirchhoff's laws);

$\lambda \approx L$, microwave theory or electromagnetic-field theory;

$\lambda \ll L$, optics or ray theory,

where λ is the wavelength and L is the nominal size of the system that generates the field.

When the first equation is satisfied Kirchhoff's laws can be applied. Since the free-space wavelength at 1MHz is 300m, any system that will fit in an ordinary room can usually be treated by circuit theory at frequencies of 1MHz and below that (Durney et al., 1986). When the dimension of the wavelength is approximately equal with respect to the length of the source (from 300 MHz to 300 GHz) most systems must be treated by microwave theory, and finally, the theory of optics can be used for most systems at frequencies above of 300 GHz.

For this reason, two different approaches have been developed in order to face this issue, i.e. the near and the far field. Near fields are present close to the sources of EMFs and are characterized by a non-homogeneous behaviour; in fact, the equation that mathematically represents near fields contains the terms $1/\mathbf{r}$, or $1/\mathbf{r}^2$, or $1/\mathbf{r}^3$, where \mathbf{r} is the distance between the source and the target point. In addition, objects placed close to the source of electromagnetic field may dramatically alter the nature of the field, and for this reason these fields are very complicated to be studied.

At certain distances from the source, the terms $1/\mathbf{r}^2$ and $1/\mathbf{r}^3$ can be ignored with compared to the term $1/\mathbf{r}$; in this case, fields are called far fields and waves can be considered plane waves in a limited region of space. Plane waves are characterized by some properties:

1. The wave fronts are planes (Figure 6).
2. The electric field (**E**), the magnetic field (**H**) and the direction of propagation (**k**) are all mutually perpendicular.
3. There is a mathematical relationship between **E** and **H**; in fact, the impedance, i.e. ratio between the module of electric and the magnetic field, is a constant value and is 377 ohm for free space. For this reason, it is easier to study far fields than the complicated relationships concerning near fields.

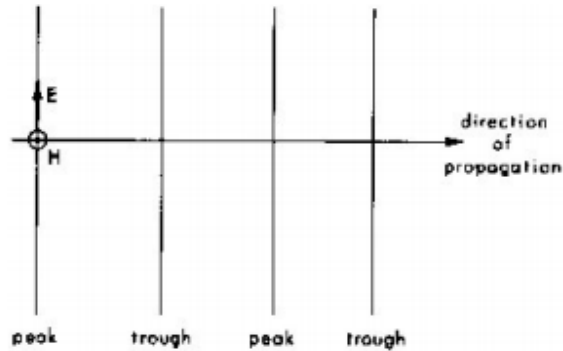

Figure 6. Plane waves from far field. (from Durney et al., 1986)

The boundary between near-field and far-field regions is taken to be:

$$d = 2 L^2 / \lambda,$$

where

d is the distance from the source.

L is the largest dimension of the source.

λ is the wavelength of the fields.

3.4. Interactions of fields with matter

Electric and magnetic fields interact with matter in two ways. The **E**- and **B**-fields exert forces on the charged particles in the materials, thus altering the charge pattern that originally existed. Furthermore, they produce additional **E**- and **B**-fields (in addition to the fields that were originally applied). Materials are usually classified as being either magnetic or nonmagnetic.

In nonmagnetic materials, the applied **E**-field may have a dominant effect on the charges in the material. This occurs in three primary ways:

- a. Polarization of bound charges.
- b. Orientation of permanent dipoles.
- c. Drift of conduction charges.

Materials primarily affected by the first two kinds of effect are called dielectrics; materials primarily affected by the drift of conduction charges are called conductors.

The first effect is produced by the presence of an external electric field which can separate the opposite charges in material, thus producing an induced dielectric dipole (Figure 7 (a)).

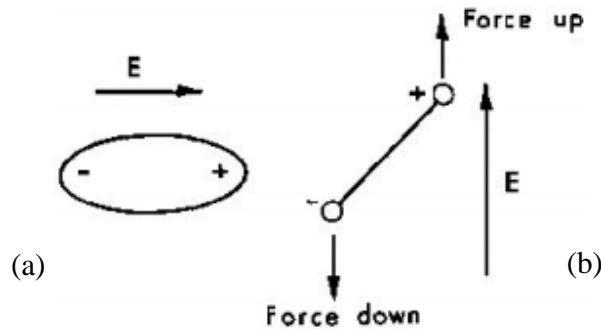

Figure 7. Representation of bound charges (a) and orientation of permanent dipoles (b) (from Durney et al., 1986).

The second effect is generated when the presence of an electric field, applied to an existing dipole, tends to align the dipole with the applied \mathbf{E} -field itself (Figure 7 (b)). Like induced dipoles, this net alignment of permanent dipoles produces new fields.

Finally, the drift of conduction charges in an applied \mathbf{E} -field occurs when the electric field is able to induce both electrons and ions to move in response to forces of the applied fields. This phenomenon amounts to new current fields. All these phenomena lead to two characteristics of non-magnetic materials, i.e. permittivity and conductivity. The first is a measure of how easily the polarization in a material occurs. The drift of conduction charges is accounted for a quantity called conductivity which is a measure of how much drift occurs for a given external electric field.

The energy transferred from applied \mathbf{E} -fields to materials is in the form of kinetic energy of the charged particles in the material. The energy transferred to the material is often called specific absorption rate (SAR). For steady-state sinusoidal fields, the time-averaged power absorbed per unit volume at a point inside an absorber is given by the following formula:

$\mathbf{P} = \sigma \mathbf{E}^2$, where σ is the effective conductivity and \mathbf{E} is the root mean square magnitude of the electric field at that point inside the material.

Finally, the resulting motion of the magnetic dipoles induced by the presence of an external magnetic field produces a current that creates new electric and magnetic fields. This property of materials is called permeability. Nevertheless, this phenomenon is not very important because biological materials are mostly nonmagnetic.

3.4.1. Electrical properties of biological tissue

Permeability and permittivity are the most relevant variables that characterize electrical properties of biological matter; concerning the first property, permeability is essentially equal to that of free space, for biological tissues are essentially nonmagnetic. Permittivity strongly depends on frequency; in particular, two components of permittivity can be distinguished: ϵ' is primarily a measure of the relative amount of polarization that occurs for a given applied electric field, and ϵ'' is connected with both the friction associated with changing polarization and the drift of conduction charges. ϵ'' mostly represents ionic conductivity and absorption due to relaxational processes in tissues, including friction associated with the alignment of electric dipoles and with vibrational and rotational motion in molecules. As represented in figure 8, both the terms of permittivity are strictly connected with frequency and they diminish with the increase in frequency, thus showing the inability of the charges to respond to the higher frequencies of the applied fields inside the tissues.

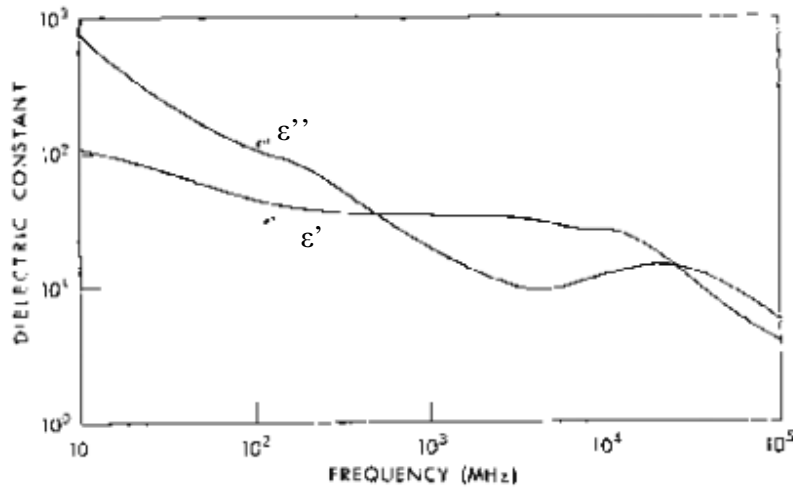

Figure 8. Average permittivity of human body (from Durney et al., 1986).

3.4.2. Planar absorption

Also the absorption of energy is strongly related with frequency in tissues; the calculation of this parameter is very difficult, and sometimes it represents a great challenge; nevertheless, some models have been proposed to face this issue. Planar models are the simplest approach to provide important qualitative understanding of energy-absorption characteristics; when a planewave is incident on a planar dielectric object, the wave transmitted into the dielectric attenuates as it travels, and transfers energy to the dielectric. This characteristic is described by skin depth, i.e. the depth at which the electric and magnetic fields have decreased to e^{-1} ($e^{-1} = 0.368$) of their value at the surface of the dielectric; figure 9 shows that skin depth is high at low frequencies, so the energy penetrates the tissue, while it is very low at very high frequencies, thus irradiation will primarily result in surface heating.

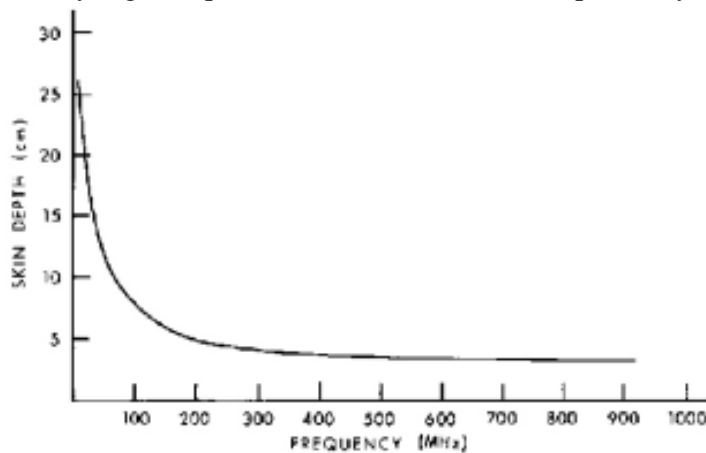

Figure 9. Skin depth depending on frequency (from Durney et al., 1986).

Other more complicated models such as spheres, cylinders and prolate spheroids have been used to represent whole bodies or specific tissue for the study, and the assessment of energy absorbed during planewave irradiation. Many variables play an important role in the absorption, i.e. frequency of exposure, the shape of the assayed structure and the intrinsic dielectric properties of the tissue. The effects of polarization of the incident fields are important for nonplanar objects and for obtaining more

realistic models. The orientation of incident electric and magnetic field and the direction of propagation of the wave (\mathbf{k}) with respect to the exposed object is crucial when evaluating the energy absorbed by the element; this phenomenon is named polarization of the incident field; for those objects obtained by the revolution of an axis (e.g. a cylinder or a prolate spheroid) the polarization is defined by the incident-field vector- \mathbf{E} , \mathbf{H} , or \mathbf{k} - parallel to the longest axis of the body. Thus, \mathbf{E} , \mathbf{H} or \mathbf{k} polarization can be distinguished (Figure 10).

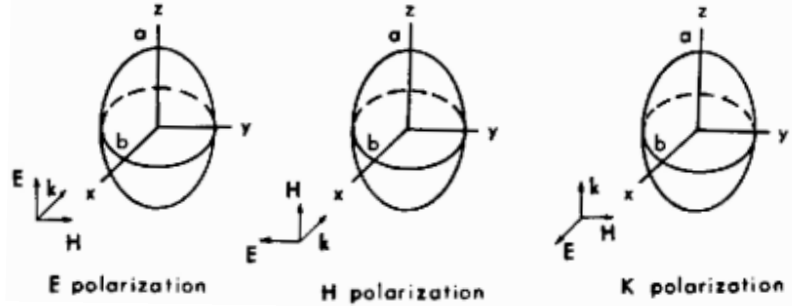

Figure 10. Types of polarization in a prolate spheroid ($x > y > z$ are the three semi-axes) (from Durney et al., 1986).

3.4.3. Specific absorption rate (SAR)

In dosimetry, SAR is defined as the transfer of energy from electric and magnetic field to charged particles in an absorber (Durney et al., 1986). Generally, SAR is defined as the time rate of energy absorbed by an infinitesimal volume at a specific point and it is formalized by the following formula:

$$\text{SAR} = [\partial W / \partial t] / \rho_m,$$

where ρ_m is the mass density of the object at that point of calculated SAR. Then, two categories of SAR can be individuated, i.e. local SAR and whole body-average SAR.

Local SAR or SAR distribution is defined with the equation:

$$\text{SAR} = \sigma |\mathbf{E}|^2 / \rho_i,$$

where σ is the conductivity of the material exposed to an electromagnetic field at a given point and $|\mathbf{E}|$ is the module of the internal electric field measured at the point in the object.

The average SAR is defined as the time rate of change of the total energy transferred to the total volume of the absorber, divided by the total mass of the body:

$$\text{SAR} = \int_v W \, dV / M,$$

where M is the total mass of the object.

The quantification of SAR is very important because it permits to unify the evaluation of the absorption of energy in an object exposed to an external electromagnetic field. SAR dramatically depends on frequency of incident field and a significant example is given in figure 11 for an averaged-size man. Below resonance SAR, i.e. where a maximum value of SAR is reported, the curves goes like f^2 , while just beyond the frequency of resonance SAR varies as $1/f$. The curve also indicates that, below resonance, SAR is higher for \mathbf{E} polarization and lower for \mathbf{H} polarization. This is due to the fact that the absorption of energy is maximised when the body is parallel to \mathbf{E} -field and it is higher when the cross section of the body perpendicular to the incident \mathbf{H} -field is larger than when it is smaller.

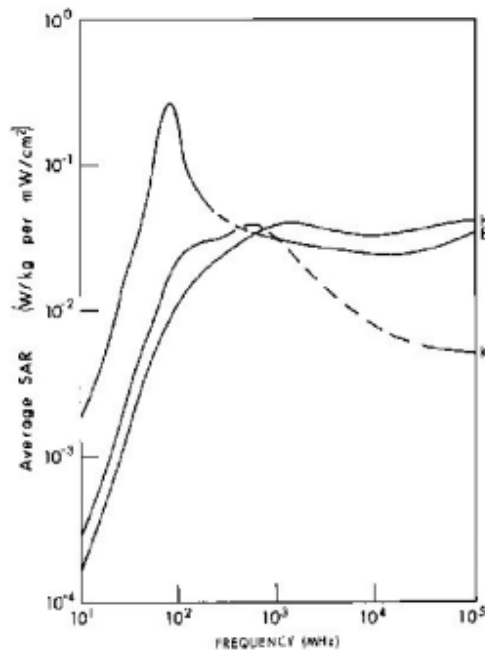

Figure 11. Specific absorption rate (SAR) vs frequency for an averaged-sized man (from Durney et al., 1986).

3.4.4. Dielectric properties and field-generated force effects

The basic dielectric properties of biological tissues play an important role in dosimetry for determining the interactions between electromagnetic fields exposure with biological systems. The two most important electrical properties are the dielectric constant (ϵ) and conductivity (δ) that both strongly depend on temperature and frequency. Figure 12 qualitatively describes the behaviour of the dielectric constant depending on frequency for a muscle tissue, but the trend observed is practically valid for all tissues. Two remarkable observations can be argued: first of all, dielectric constant decreases with frequency, and three regions, α , β , γ can be distinguished.

The dielectric constant and conductivity are totally symmetric due to the relaxation of the different mechanisms of polarization (that characterizes dielectric constant) for increasing values of frequencies and the concomitant increase in capacitance and conductance changes for each relaxation mechanism.

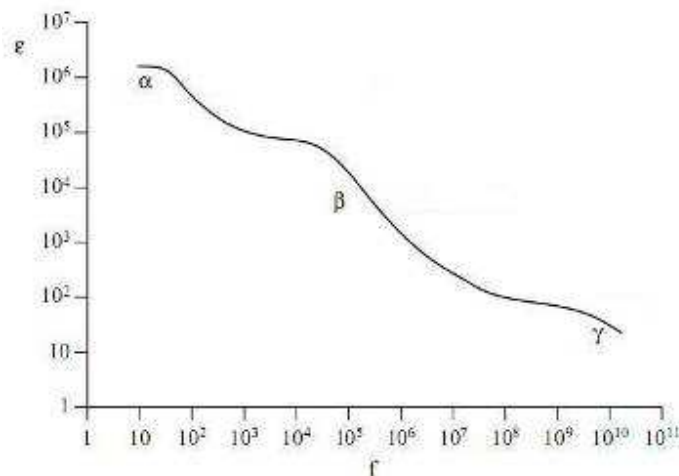

Figure 12. Dielectric constant trend (ϵ) vs frequency (f) (from Andreuccetti et al., 2001).

The three regions of relaxation contribute to gross and fine structure relaxation effects, depending on the particular tissue. The α dispersion is the least clarified and some theories have been presented; some researchers hypothesize that this behaviour is due to ions diffusion processes through the boundary electric layer of membranes or the migration of ions through the pores of cellular membrane (Andreuccetti et al., 2001). β dispersion is strictly connected with the relaxation of polarization processes due to the great amount of charges in correspondence with cellular membranes, i.e. membranes through intra- and extracellular fluids (Maxwell-Wagner effect). Rotation of molecules having a permanent dipole moment, such as water and proteins, is responsible for the γ -dispersion (water) and its relaxational behaviour is near about 20GHz. Between region β and γ -dispersion an additional relaxation region (δ) is caused by rotation of amino acids, partial rotation of charged side groups of proteins, and relaxation of protein-bound water.

All these dispersion factors differently contribute in displaying the relaxation mechanisms, as it is exemplified in table 5; for example, electrolytes display only the γ -dispersion which is peculiar of water. To the water's γ -dispersion, biological macromolecules and aminoacids add a δ -dispersion; this phenomenon is caused by bound water and rotating side groups in the case of proteins, and by rotation of the total molecule in the case of the aminoacids; then, proteins and nucleic acids add further dispersions in the β - and α -range as indicated (Schwan, 1975).

Biological components	Relaxation mechanisms
Electrolytes	γ
Biological macromolecules, Amino Acids	$\gamma + \delta$
Proteins	$\beta + \gamma + \delta$
Nucleic Acids	$\alpha + \beta + \gamma + \delta$
Cells, free of protein	$\beta + \gamma$
Charged with excitable membranes	$\alpha + \beta + \gamma$

Table 5. Relationship between relaxation mechanisms and biological components (from Schwan, 1975).

In addition to relaxation mechanisms, electromagnetic fields can directly interact with biological components by producing forces that can act on molecules and other large structures. An example is given by the movement of ions in an ACF (alternating current field), which can occur whether the field is weak enough to prevent undue heating from molecular collisions (e.g., below about 1V/cm, corresponding to 1mA/cm² in a physiological medium) or not. Another example is the orientation of polar macromolecules (Durney et al., 1986). Electric fields can interact just as well with nonpolar cells and organelles in the absence of any net charge; as a consequence, any system exposed to an electric field will tend to minimize its electric potential energy by appropriate rearrangement. Nevertheless, it has been long demonstrated that electromagnetic fields can dramatically affect the behaviour of cells and cells themselves can be deformed or destroyed (Zirmerman et al., 1974; Alvarez-Rodriguez et al., 1985). Thus, the threshold values of a cellular response or more dramatic consequences, like cell death, are assumed to be reached when the induced membrane potential reaches the breakthrough levels, ranging from 0.1 to 1V/m across the membrane (Durney et al., 1986). Moreover, two main mechanisms, that describe these adding forces from applied electromagnetic fields and the interactions processes by which applied fields may elicit biological responses, are widely studied, i.e. thermal and non-thermal mechanisms (Foster, 2000). Concerning the first group, some effects can be observed after both bulk temperature increase and from rate of temperature increase, even though the mass temperature rise is small. For example, a brief pulse that deposits 1J/kg in a muscle will produce a transient increase in temperature of approximately $3 \cdot 10^{-4}$ K or a continuous-wave RF field of 30V/m (at

1GHz) will produce a SAR of about 1W/kg, which corresponds approximately to the basal metabolic rate of humans (Foster, 2000). Concerning the other phenomenon, transient increases of temperature can elicit auditory sensations in an exposed individual (microwave hearing) (Foster and Finch, 1974); in addition, Wachtel et al., (1990) reported altered movements in mice whose heads were treated with intense pulse energy (500-1000J/Kg). The related increase in temperature implies significant changes in cell membranes potential.

Unlike thermal effects, nonthermal effects (also called low-level exposures) are characterized by not producing relevant changes in internal temperatures or challenge in thermoregulation of assayed organisms (Repacholi, 1998); in this case, the amount of energy absorbed by the organisms is too small or too dispersed to generate observable thermal effects, however, a wide spectrum of biological effects has been reported in literature. Low-level exposures affect a wide range of ion-channels properties, such as decreased rates of channel formation and decreased frequency of single channel openings (Repacholi, 1998). Effects on transport of Na^+ and K^+ across cell membranes after exposure to radiofrequency electromagnetic fields implies changes in cell membrane without temperature increases (Cleary, 1995). These effects occurred at frequencies ranging from 27MHz to 10GHz and over a wide range of SAR (0.2-200W/Kg). Also modulated electromagnetic fields induced membrane effects; in particular, RF fields amplitude modulated ELF frequencies, induced Ca^{2+} efflux from nerve cells or brain tissue *in vitro* (Adey, 1981). Nevertheless, other studies failed to find similar results, maybe due to the lacking of specific and homogenous protocols among different laboratories and the change in some parameters during laboratory exposures (e.g. different modulation signals) (Wood et al., 1993).

Low-level RF exposure also affects signal transduction processes and cell proliferation. Ornithine decarboxylase (ODC), an enzyme involved in activity of mitogens, whose activity is strictly connected with signalling events, significantly increased in human melanoma cells and rat hepatoma cells after RF (450MHz) amplitude modulated field (Byus et al., 1988). Moreover, effects on transcription, measured by specific RNA precursors, i.e. [^3H]uridine or DNA precursors, such as [^3H]thymidine, on glioma cells after radiofrequency exposures were reported (Cleary et al., 1990).

Many controversial studies have been obtained by studying the relationships between low-level radiofrequency and mutagenicity; up to few years ago all the reviews on this topic indicated a low influence of RF fields on DNA, and most of positive findings, such as DNA strand breaks, sister chromatid exchange or chromosome aberrations occurred under elevated exposures which led to high increase in temperature of exposed tissues (Brusick, 1995). Nevertheless, recent papers indicate that also low-level RF exposure can induce damages on DNA; for this reason is important to briefly describe the state of the art of this topic; in the following paragraphs the two most relevant anthropic sources of RF and microwave fields will be briefly described and some recent results acknowledgments from studies concerning the relationship between electromagnetic exposure at radiofrequencies and microwave frequencies and DNA damage will be reported.

3.5. Human sources of radiofrequency-microwave emissions

The use of radiofrequencies and microwaves devices is widespread all over the world and it has a wide range of applications, such as communications, broadcasting, medical and industrial applications. In this paragraph a brief description of the most important anthropic sources belonging to radio-microwave frequencies range will be reported by mainly considering radio-TV broadcasting and mobile-communication services whose frequency range have been studied in the present project.

The frequency spectrum of radio and communication systems ranges from about 0.5MHz (AM radio frequencies) to about 1GHz (private and public broadcasting systems) with maximum values of power ranging from few kilowatts to hundreds of kilowatts (Andreuccetti et al., 2001) (Figure 13).

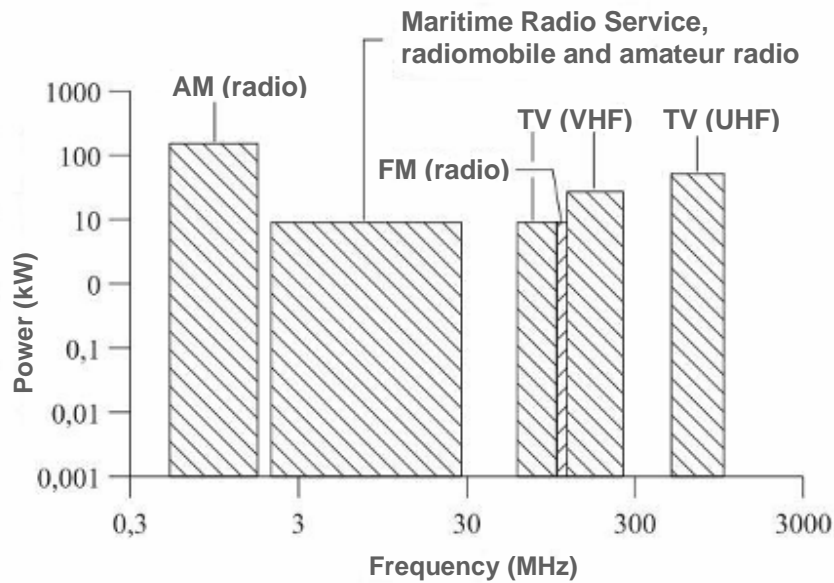

Figure 13. Frequencies and powers of some devices for broadcasting service (adapted from Andreuccetti et al., 2001).

Generally, antennas from broadcasting services can be divided into two different groups according to the area covered by the signal transmitted by a source: if the information has to be sent in a wide area, antennas with a low gain (defined as the rate between the input power or the input amplitude of a specific signal and the respective output) and omnidirectional radiation (360°) is used. On the other hand, if a specific territory has to be covered, then high gain antennas with a horizontal beam less than 180° will be used. Concerning the risks for environmental health assessment from TV and FM antennas, significant levels of electric and magnetic fields are mostly concentrated near the transmitter antenna (50-100m), while relevant electric fields (about 100V/m) produced by amplitude modulated devices occur near the source itself (Andreuccetti et al., 2001).

In the last decade, as a consequence of public concern on this topic most of the new broadcasting antennas accumulated far from cities and lower density powers have been detected ($0.03-0.1\text{W/m}^2$) (Andreuccetti et al., 2001). Nevertheless, in places where high power ultra high frequencies (UHF) and very high frequencies (VHF) broadcasting antenna systems are located on buildings in residential areas, the problems may be more evident (Kitchen, 2001).

Mobile communication systems antennas can transmit and receive information within specific frequency ranges that are briefly described in table 6. GSM 900 and GSM 1800 (also called DCS) systems together with UMTS/WCDMA are the most used mobile communication systems; nevertheless, the UMTS system has not been collected with other systems for it is based on multiple bands with different ranges of both transmission (uplink) and receiving (downlink) frequencies.

Mobile system	Tx (MHz)	Rx (MHz)
RTSM	450÷455	460÷465
TACS	890÷915	935÷960
GSM 900	890÷915	935÷960
GSM 1800	1710÷1785	1805÷1880
DECT	1880÷1900	

Table 6. Frequency ranges for mobile communication systems (adapted from Andreuccetti et al., 2001).

Base station antennas, which characterize radio-mobile communication systems, may be found as separate masts or shared masts on roof tops and similar places because they offer the maximum return in terms of potential area coverage. Sectoral antennas can be mainly used for the coverage of specific, “sectors”; for this reason, rectangular flat antennas can be arranged to give a particular angular coverage, such as 45°, 60°, 90°, 120°, or other divisions, according to the need (Kitchen, 2001). Omnidirectional antennas are used when complete 360° coverage is needed. For this requirement, collinear types, consisting of two or more dipoles are disposed vertically and fed in series or parallel; figure 14 shows two examples for sectoral and omindirectional coverages, respectively.

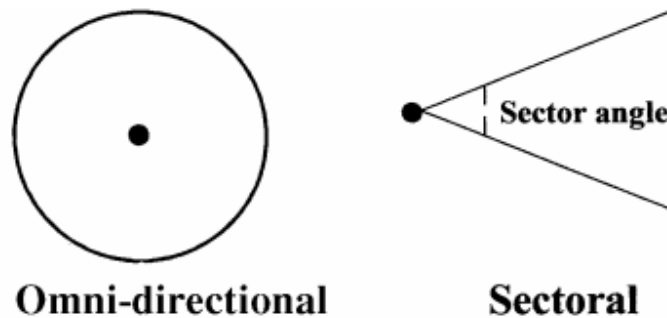

Figure 14. Omni-directional and sectoral antenna coverages (from Kitchen, 2001).

Figure 15 shows two distinct structures of a sector and omnidirectional antennas. The degree sector antenna showed in figure 15 is typically characterized by a linear vertical polarization, with an azimuth beamwidth of 60° and a frequency ranging from 870 to 960MHz. The beamwidth is defined as the width in degrees of angle between the opposite points corresponding to a 3dB reduction in power density relative to the axis, thus corresponding to two-fold decrease in power density (Kitchen, 2001). The collinear antenna covers 825 to 896MHz and has 360° coverage.

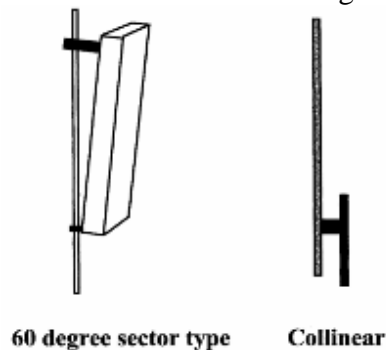

Figure 15. Sectoral and omni-directional antennas (from Kitchen, 2001).

It has been generally ascertained that the power from mobile phone systems antennas on high masts, e.g. on roof buildings, constantly decreases as approaching to the ground. Figure 16 represents a diagram of decreasing levels of power density expressed as a percentage of the locally permitted limit of 2W/m² for a structure composed by four transmitters working at 900MHz, mounted on a mast (Kitchen R, 2001). From the diagram, it can be observed that the decrease of power density is not proportional with compared to the distance from the source for the particular beamwidth, depending for the particular need.

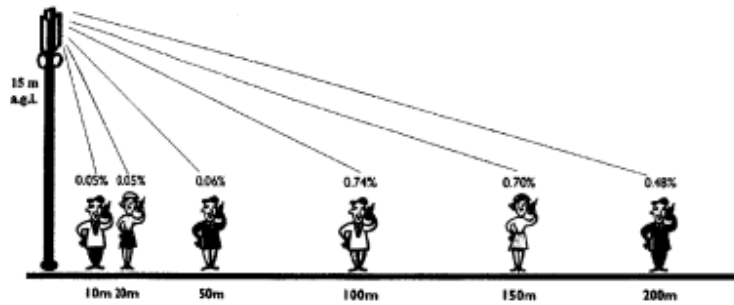

Figure 16. Levels from mast-mounted antennas as a percentage of a permitted level of $2\text{W}/\text{m}^2$ (from Kitchen, 2001).

3.6. Genetic effects of radiofrequency-microwave fields

Experiments on animals *in vivo* and cells *in vitro* by assessing damages on DNA after exposures to various radiofrequency signals have produced many different data in literature; as a result, detrimental effects on environmental and human health is still a contentious issue (Phillips et al., 2009).

It has also to be said that many confounding variables can influence the outcome of experiments by analyzing radiofrequency fields (Verschaeve, 2005). First of all, it is important to consider the energy absorbed by a test organism and how the energy is distributed in space and time; furthermore, frequency, time of exposure and continuous or pulsed field have also to be taken into account (Lai, 1998). Then, the technology of cell phone transmissions is constantly changing, thus making some transmission patterns used by some researches not applicable by other types. Finally, another confounding variable consists in the cell or the organism chosen for the study; indeed, as different biological models have been studied, different organism or cell types have different responses (Höytö et al., 2007; Di Carlo and Litoviz, 1999). Moreover, interlaboratory investigations (Malyapa et al., 1997), to confirm some positive results obtained by previous studies (Lai and Singh, 1996), failed for differences in methodology.

Another important concern about the relationship between biological effects and radiofrequency exposure refers to the belief that all the findings could be related to the secondary thermal effects, and that, if thermal effects were eliminated, radiofrequencies were not able to produce biological consequences, like chromosome damage (Kerbacher et al., 1990) or alterations to sperm (Berman et al., 1980), respectively. Nevertheless, more recent reviews reported different implications on this particular issue, thus describing some examples of biological effects resulting from low-level (called also non-thermal) radiofrequency exposure. Mashevich et al. (2003) exposed peripheral blood cell lymphocytes to 830MHz frequency at different rates of energy (SAR) ranging from 1.6 to 8.8W/Kg; an increase in chromosome 17 aneuploidy was observed, linearly varying with SAR, independently from increases in temperature (from 34.5°C to 38.5°C). For this reason, researchers have concluded that genotoxic effects were elicited through non-thermal pathways.

Reviews from last two decades concerning cytogenetic effects after radiofrequency radiation (RFR) exposures (Brusick et al., 1995; Verschaeve et Maes, 1998) supported the conclusion that there was a lacking of induction of negative alterations on DNA associated with RFR treatments. Gene mutation studies reported negative results for both microbial systems (Hamnerius et al., 1985) and mammalian cell lines (Meltz et al., 1989); furthermore, studies chromosome alterations, such as structural aberrations, numerical alterations, micronuclei formation (MN) and sister chromatid exchange (SCE) showed sporadic positive issues which were not confirmed (Brusick et al., 1998). In fact, the increase in micronuclei and aberrations in cultured cells from radar station workers reported by Garaj-Vrhovac et al. (1990) were not confirmed by following investigations (Garson et al., 1991). Other studies on

chromosome alterations detected in technical problems, such as controls of hyperthermia and appropriate controls, generating misleading data. For example, increase in aberrations found in CHO-K1 cells exposed to 2450MHz was observed only at 42°C, while controls held at 29°C did not show the same significant trend, thus the effect resulting exclusively in hyperthermia (Alam et al., 1978). In addition, most of the studies on induction of DNA repair processes, such as those DNA damages that are subject to excision repair mechanisms on microbial systems (Mezykowski et al., 1980) and cultured mammalian cells (Meltz et al., 1987) did not produced effects, mainly for they were not designed under appropriate conditions for risk assessment (Brusick et al., 1998).

In contrast to the aforementioned reviews, recent papers (Phillips et al., 2009; Ruediger, 2009) pointed out that non-thermal genotoxic effects of radiofrequency signals have been convincingly demonstrated, by performing laboratory experiments with different test systems. In particular, two principal endpoints, i.e. effect on chromosomes and DNA fragmentation were proposed; for the first topic, increased levels of aneuploidy of chromosome 10, 11, and 17 have been observed after radiofrequency exposure in human lymphocytes (Mazor et al., 2008); moreover, alterations of the spindle apparatus after radiofrequency electromagnetic fields were observed in two recent studies (Pavicic and Trosic, 2008; Tkalec et al., 2009) and a negative effect on the basis of the size distribution of micronuclei was reported in another investigation (Fucic et al., 1992).

The Single Cell Gel Electrophoresis (SCGE) and the detection of checkpoints proteins, such as H2AX for assessing double strand breaks are the most relevant approaches for the detection of DNA fragmentation. SCGE or comet assay is used during interphase cellular cycle and is based on the migration to the positive pole of DNA molecule undergoing to an electric field, thus forming comet-like tail (Singh et al., 1988); recently, comet-positive studied have been performed both *in vitro* and *in vivo* experiments; for example, Diem et al. (2005) assayed cultured human fibroblasts and rat granulosa cells under continuous and intermittent different mobile phone modulation (1800MHz carrier frequency) and at different levels of SAR (from 1.2 to 2.0W/Kg). Finally, they concluded that intermittent exposure showed stronger effects on DNA breakages than for continuous waves. Moreover, Paulraj and Behari (2006) reported that low intensity microwaves (2.45 and 16.5GHz, SAR 1.0 and 2.05W/Kg, respectively) induced significant increases in DNA single strand breaks in brain cells of Wistar rats after chronic exposure of animals to electromagnetic fields. Furthermore, Gandhi (2005) demonstrated that a significant increase in strand breaks was observed in 24 mobile phone users with respect to the control group, by analyzing *in vivo* capillary blood genotoxic parameters from comet assay test.

H2AX, a member of histone family, is a double strand breaks checkpoint protein, which is quickly phosphorylated after DNA damage and then gathered closely to DNA double strand breaks; then, foci can be visualized by using immunofluorescence (Fernandez-Capetillo et al., 2004); this approach was adopted by Yao et al (2008) to find significant increasing in double strand breaks by γ H2AX foci in human lens epithelial cells after exposure to 1.8GHz radiofrequency fields at intermittent exposure and at different absorption rates, ranging from 1 to 4W/Kg.

It is also interesting to note that two main theoretical mechanisms have been proposed for explaining positive results after radiofrequency and microwave electromagnetic exposure, so far; the energy of weak RF fields is able only to excite electrons to a higher energy state and it is not sufficient to break directly a chemical bond in DNA (Ruediger, 2009). So, it can be argued that mediated genotoxic effects by other processes, such as the generation of free radicals or alteration of repair processes may be involved.

Several articles reported that oxygen radicals can be produced after electromagnetic fields exposure both *in vivo* (Lai and Singh, 1997; Oktem et al., 2005) and *in vitro* experiments (Zmyslony et al., 2004; Yao et al., 2008), and in particular via Fenton reaction (Lai and Singh, 2004); the Fenton reaction is a

mechanism catalyzed by iron ion (Fe^{2+}) in which hydrogen peroxide is converted into hydroxyl radicals, which have deleterious effects on cells (Phillips et al., 2009); in fact, radicals can damage macromolecules, such as protein and membrane lipids; in addition, they also affect DNA by forming base adducts in DNA, the most important being the oxidized nucleoside 8-hydroxydeoxyguanosine (8-OHdG) and oxidize membrane lipids whose reactive species may couple with DNA (Valko et al., 2004).

Investigations on combined effects of radiofrequency radiations and other well known genotoxic agents (chemical compounds or physical agents) have been also performed. Balcer-Kubiczek and Harrison (1991) observed that RF radiation alone did not induce cell transformation in C3H/10T1/2 mouse cells under 2450MHz modulated fields, but the combined exposures with benzopyrene induced morphologic cell transformation. Furthermore, a clear enhanced sister chromatid exchange frequency (Maes et al., 1996) was detected in human lymphocytes undergoing to 954MHz microwaves in presence of the chemical DNA damaging agent mitomycin C (MMC), with compared to cells that were exposed to the chemical compound alone. Lai and Singh (1997) found also that two oxyradicals scavengers blocked the increase in single and double strand breaks after 2450MHz radiofrequency exposure in rat brain cells, thus hypothesizing a repair mechanism involved in these events.

Recently, Baohong et al. (2007) found that a combinative exposure to microwaves 1800MHz plus 254nm UVC rays exposure increased DNA damage in human blood lymphocytes with respect to UVC alone; these results suggested that 1800MHz microwave exposure might inhibit both the incision and the ligation step of excision repair mechanism that are involved in repair of DNA damage caused by UVC exposure.

Concerning directly the effects from mobile radio base stations, investigations have been reported both in human studies and by performing laboratory experiments. Garaj-Vrhovac (1999) reported an increase in micronucleus frequency in lymphocytes of some subjects occupationally exposed to microwave radiations, i.e. employed on antenna system service. The average age of employment duration ranged from 10 to 19 years and the control group consisted in non-smoking subjects of similar age of the exposed. Nevertheless, more recent studies did not confirm previous data; for example, Maes et al., (2006) investigated cytogenetic effects on peripheral blood lymphocytes of subjects working for a mobile phone company; the cytogenetic tests, i.e. comet assay, SCE and chromosome aberration test did not reveal evidence of RF radiation-induced genotoxicity.

Concerning *in vitro* studies on mobile radio base stations RF fields-like, quite controversial results have been found; Phillips et al., (1998) reported an increase in single-strand breaks in Molt-4 T-lymphoblastoid exposed to different mobile telephone signals; nevertheless, more recent studies failed to corroborate previous results. Hirose et al. (2007) observed that continuous and modulated W-CDMA signal RF fields at 2.1425GHz did not induce significant difference in heat shock protein (hsp) gene family or phosphorylation of hsp 27 on human glioblastoma A172 cell line and human IMR -90 fibroblast cell line; Sekijima et al., (2010) confirmed the previous observations, thus indicating that a limited evidence of genotoxic potential was assigned to mobile phone base stations.

However, very recent *in vivo* experiments found deleterious effects on DNA after exposures to mobile phone antennas; Guler et al. (2010) observed an enhancement of oxidative DNA damage by quantifying 8-hydroxy-2'-deoxyguanosine (8-OHdG) and lipid peroxidation levels in the brain tissue of pregnant and non-pregnant New Zealand White rabbits exposed to 1800MHz GSM frequency and 14 V/m as reference level of electric field. Moreover, Panagopoulos et al., (2010) showed that the reproductive capacity of adult *Drosophila melanogaster* by cell death induction decreased after the insects were exposed to GSM 900 and 1800 (Global System for Mobile Telecommunications) radiations at different distances from antenna (ranging from 1 to 100cm).

Electromagnetic field characteristics

Finally, for the complexity of this public concerned topic and the great amount but controversial results present in scientific literature, it is important to deep with the study on this issue and additional research in these areas are required to clarify the possibility of an interaction between genotoxicity and the radiofrequency and microwave energy from mobile telecommunications.



4. AIM OF THE STUDY

In the last decades, we assisted to a dramatic increase of personal telecommunication devices and their base station antennas (BTS) all over the world, giving a consequent increasing concern about the possible adverse effects of exposure to radiofrequency/microwave electromagnetic field (RF/MW EMF). Electromagnetic fields are classified as nonionizing radiation, since they cannot interact directly with DNA. Nevertheless, many controversial results were obtained after investigations on this topic and some findings suggested that they produce damages on DNA (Lai and Singh, 1995, 1996); on the other hand, several authors reported no increase in genotoxicity after microwave exposure (Malyapa et al. 1998; Vijayalaxmi et al. 1997). Most of the literature data concerning this issue comes from epidemiological (Kurana et al. 2009), *in vitro* (Franzellitti et al. 2010), and *in vivo* (Paulraj and Behari, 2006) studies, including chromosomal aberrations, micronucleus induction, sister chromatide exchange and DNA fragmentation (Ruediger, 2009), as endpoints. Although the energy of EMF is too low to break the chemical bonds in DNA, nevertheless, most of the studies proposed that thermal effects mainly produce adverse effects on DNA, i.e. a considerable local heating of tissues after a low energy microwave exposure (Schwarz et al. 2008).

However, non-thermal effects, such as the generation of oxygen radicals (ROS) (Zmyslony et al., 2004) or a disturbance of DNA-repair processes after a combination of exposure to radiofrequency and chemical or physical mutagens (Baohong et al 2005, Meltz et al. 1987) were also taken into account as proposed mechanisms of RF-EMF genotoxicity. In particular, although only a few investigations about the effects of microwaves exposures on UV-induced cell DNA repair have been assessed, previous studies on human blood lymphocytes showed that RF fields might influence the excision repair process after 254nm UVC exposure (Baohong et al. 2007).

Apart from the lacking of a univocal statement of the potential genotoxicity of electromagnetic fields, there is a further issue; in fact, despite the fact that the radiofrequency and microwave electromagnetic fields have been widely studied by laboratory approaches, biological effects on biological indicators have been not exhaustively assessed under field exposures, where realistic conditions are present. The development of bioindicator species is based on the choice of appropriate organisms and the analysis of molecular and cellular biomarkers that reflects the induction of specific responses or the appearance of toxic effects caused by environmental changes; in addition, cellular and animal approaches are performed in order to assess causality and biological plausibility. Despite the fact that microwave fields have been mainly studied under laboratory conditions, genotoxic effects have not been yet assessed on bioindicators under natural conditions of radiofrequency exposures from anthropic sources and only one proposal of using a biological indicator for extremely low electromagnetic fields was reported (Regoli et al., 2005). For our purposes, we chose the *Eisenia fetida* (Anellida; Oligocheta) as test organism, for it is widely used for toxicity assays by several international organizations (OECD, 2000). In addition, the ease of handling and low cost make *E.fetida* a valuable species for soil contamination monitoring and an important indicator to examine the biological effects of xenobiotics under laboratory conditions (Bergknut et al., 2007). In particular, we assayed the cells present in the coelomatic cavity of the animals. Many authors believe that the coelomocytes of invertebrates are the evolutionary precursor of all known vertebrate immunocytes (Cooper 2002) and bioassays using invertebrate surrogate, like earthworms, in place of vertebrates to assess risks of environmental contaminants have been previously used (Burch et al., 1999). In addition, coelomocytes play an important role in immune defences of earthworms: antimicrobial defence, encapsulation reactions, phagocytosis (Manerikar et al. 2008). Invertebrates have been already used to study the adverse effects of electromagnetic fields (de Pomerai et al. 2003; Lee et al. 2008).

Aim of the study

In this respect, the main aim of this work was to assess the genotoxicity associated to RF/MW radiation at frequency of 900MHz, alone and in combination with ultraviolet ray C (UVC) on coelomocytes of the organisms. Therefore, we investigated the behaviour of genotoxicity within 24 hours after exposure, considering different times of recovery (t0, t60, t120, t180, t240, t960, t1440, referring to the minutes after exposure), and determining whether the lesions on the DNA molecule were permanent or transient. The assessment of genotoxicity was performed by using the comet assay protocol, a quite recent technique that permits to quantitatively and qualitatively identify the breaks to the single and double strand of DNA (Collins et al., 1997a).

In addition, a modified protocol of comet test was developed for test organisms to characterize the typology of genotoxic damage; in particular, two specific enzymes for oxidative damage detection, formamidopyrimidine-DNA glycosylase (FPG) and endonuclease III (EndoIII) were used for this study. Finally, T4 Endonuclease V combined with a modified comet assay protocol was used to investigate the potential influence of radiofrequency electromagnetic field on excision repair processes of UV-induced DNA damage.

Moreover, in the natural environment, organisms were exposed in the proximity of radiofrequency sources and microwave electromagnetic fields antennas, such as base transceiver stations (BTS) of mobile communications, at three different points of sampling in the city of Milan. The aim was to study the potential use of *E.fetida* as a sensitive and valuable biological indicator for the assessment of genotoxicity after very high and ultrahigh electromagnetic fields. The possible interference of other environmental parameters as confounding variables (air temperature, CO, NO₂, O₃, SO₂, C₆H₆ and the polycyclic aromatic hydrocarbons (PAHs) in fine particle PM_{2.5}) with the explored biomarker was also studied.

In conclusion, the considerations resulting from laboratory and field experiments and the assessment of time-course of genotoxicity after exposure were directed to give more information of DNA damage of radiofrequency and microwave fields.

5. MATERIALS AND METHODS

5.1. Stripline configuration

In order to characterize the potential genotoxicity of microwave electromagnetic fields on bioindicator organisms, a particular device, called microstrip, that can generate the same kind of electromagnetic field produced by broadcasting antennas and base transceiver stations at a certain distance from the source was designed. Before describing the experimental conditions of our assays, a brief introduction on guided waves, microstrips and their peculiarities is given below.

A waveguide belongs to the group of transmission lines, which are defined as distributed circuit elements that guarantee the transfer of a signal from the generator to the load, by guiding an electromagnetic (EM) wave between two conductors (Figure 17).

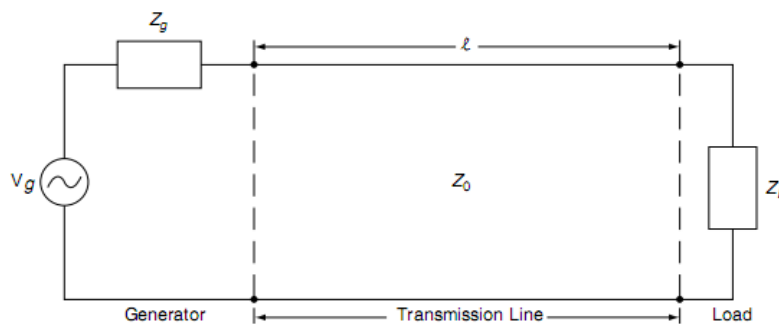

Figure 17. A transmission line of length l , and characteristic impedance Z_0 , which is connected to a generator of voltage V_g and characteristic impedance Z_g , and a load having Z_L , as impedance (from Chen, 2005).

A waveguide is capable to propagate an electromagnetic field in a preferred direction, within a specific frequency range; the direction is referred to the direction of the propagation of the wave and the frequency stands for the waveguide operating bandwidth.

When a wave is introduced at one side of the waveguide, it is reflected from the sides of the waveguide whenever it hits them; for this reason, every reflected wave interacts with the others, thus determining a number of discrete characteristic patterns, called modes. The typology of one mode depends on the geometry of the waveguide, such as the shape and size, and varies on the frequency used and the material of the waveguide.

Generally, waveguides have two main kinds of modes, transverse electric (TE) and transverse magnetic (TM); TE is characterized by no electric field component in the direction of the propagation, while TM means that no magnetic component is present along the direction of propagation. A further mode is the TEM mode, which stands for transverse electromagnetic, and it is characterized by the mutual orthogonality of magnetic, electric field with the direction of propagation. Under this condition the wave can be approximated to a plane wave which is characterized by some peculiarities, e.g. the waves fronts are planes, the rate of electric and magnetic field is a constant value, being 377 ohm for free space and the velocity of the propagation is given by the formula $v=1/\sqrt{\mu\varepsilon}$, where μ is the permeability of the medium and ε is the permittivity of the medium. Another important difference between TEM mode and TE/TM modes is that transverse electromagnetic mode can be excited at any frequency, while the other two modes can only propagate at a frequency higher than a particular frequency called the cutoff frequency. Furthermore, if the operating frequency is lower than the aforementioned cutoff frequency, then multiple modes can be present simultaneously, thus generating problems of propagation.

There are two main categories of waveguides, grouping according to the material, the metallic and the dielectric waveguides, respectively (Figure 18). The first group includes closed structures surrounded by metal that confine the field within the device; on the other hand, the dielectric waveguides are open structures where the field confinement is obtained by the dielectric constant discontinuities between the dielectric structure of the waveguide itself and free space (Chen, 2005). Finally, a third category of waveguides can be identified, the planar waveguide, which is a combination of both metal and dielectric features.

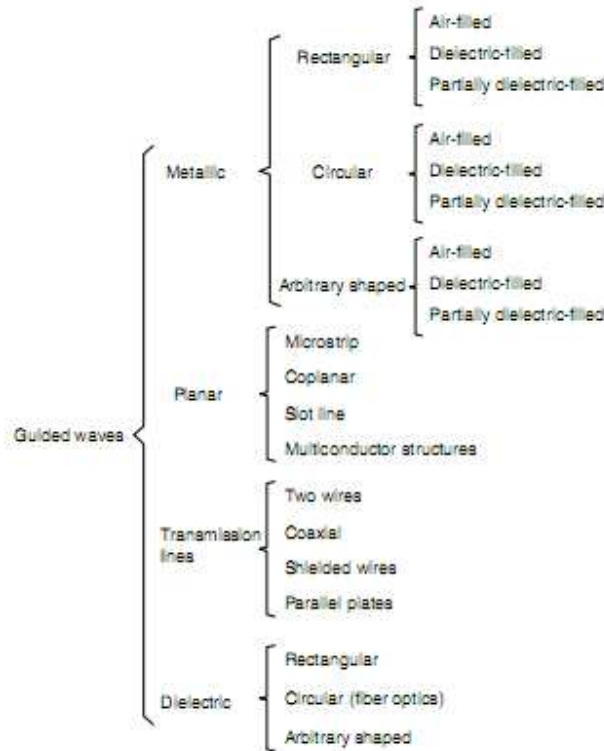

Figure 18. Classification of the most used waveguides (from Chen, 2005).

Every microwave is characterized by some parameters that univocally determine the peculiarities of a single device.

The operating frequency is the spectrum of the frequency operating in the waveguide for each field distribution, called mode.

The operation mode represents the type of field distribution and is typically divided in TE, TM and TEM, as described above.

The propagation constant (β) is defined as the rate of change of the phase angle of the signal and the phase velocity, which is the speed of the constant phase points on the wave as the wave moves.

The wavelength is the distance between consecutive corresponding points of the same phase, such as crests or troughs, as the wave propagates.

The characteristic impedance represents the ratio between the transverse electric field and the corresponding magnetic field; it is expressed by Z and is a constant value for a TEM mode, in particular, 377 ohm in free space.

Concerning the stripline configuration adopted in our research, we used a waveguide consisting of three layers, a strip conductor, a dielectric substrate and a ground plane (Figure 19).

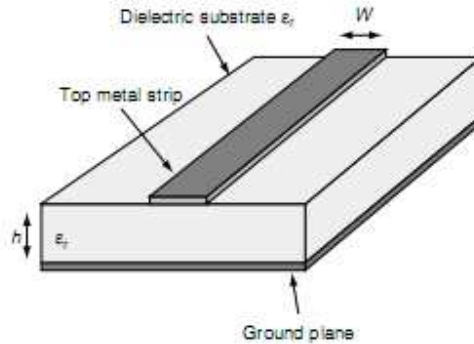

Figure 19. A schematic representation of stripline configuration. W is the width of microstrip conductor, h stands for height of the dielectric substrate and ϵ_r is the relative dielectric constant (from Chen, 2005).

Assuming a TEM mode of propagation in the microstrip line, the most important parameters characterizing the stripline are given by the following equations:

The phase velocity: $v = \frac{c}{\sqrt{\epsilon_{ff}}}$, where c is the speed of light (3×10^8 m/s) and ϵ_{ff} is the effective relative dielectric constant of the substrate.

The wavelength of the microstrip: $\lambda = \frac{v_p}{f} = \frac{c}{f\sqrt{\epsilon_{ff}}} = \frac{\lambda_0}{\sqrt{\epsilon_{ff}}}$, where f is the operating frequency and λ_0 is the free space wavelength.

The characteristic impedance: $Z = \frac{1}{v_p C}$, where C is the capacitance per unit length of the microstrip; the capacitance is the ability of a body to store electrical energy for a given electric potential.

Concerning the design and the implementation of the waveguide used during our laboratory experiments to reproduce the source of microwave electromagnetic fields generated by anthropic sources, the RF exposure system was based on a homogenous vertical \mathbf{E} fields produced in a large microstrip (Figure 20) without side walls, with the aim of obtaining a TEM condition in the measurement volume. A TEM wave with a vertical polarization propagated from the signal generator (Wayne & Kerr PSG 2400L, Chichester, West Sussex, UK) through a 50Ω coaxial transmission line. The TEM cell consisted of two parallel metal plates separated by an air gap which height gives 50-Ohm impedance. Although 3 dB losses were observed throughout the cell, the electromagnetic field inside the cell was uniform at the centre of the microstrip (where samples were put) within 1dB; as a result, the TEM cell allowed the generation of far-field conditions at the centre of the guided wave, in correspondence with the sample. No amplifier was needed to produce the required strength of electric field at microwaves. In the experiment, a single animal was put in a plastic Petri dish (30.8mm diameter) containing 3mL of distilled water and it was exposed to a 900MHz electromagnetic field for 6 minutes. For each treatment, control animals were handled in the same way than exposed and were kept outside the stripline into a metal shelter cage. The choice of the interval of exposure was made because animal data indicate an increase in body temperature and an overwhelming of the thermoregulatory capacity of the body for specific absorption rates in excess of 4W/Kg produce potential deleterious effects due to tissues heating, after prolonged exposures (ICNIRP, 1998). Contextually, according to the Italian legislation (Italian law, 1998), the measurement of

Materials and methods

electromagnetic fields is detected within a time interval of 6 minutes, because it has been shown that the thermoregulatory system of the body cannot face the increase in temperature for high electromagnetic fields (CEI, 2001) and this may lead to dramatic effects on the organism.

In order to characterize the power inside the organisms, a numeric model with FEKO software (EM Software & System – Stellenbosh, South Africa) was used. Briefly, the program is able to provide the values of electric and magnetic field as output, by entering specific inputs, such as the operating frequency and the power input. Moreover, it is possible to calculate the specific power flux density (W/m^3) and the specific absorption rate (SAR – W/Kg) of a dielectric put inside the device, dividing the power flux density by the mass density of the sample.

In our study, the model has been represented by a dish having a diameter of 30.8mm and full of 30mm distilled water depth, which simulates the Petri dish. Distilled water is represented by a dielectric with a relative permittivity of 78 and a conductivity of 0.0206S/m at 900MHz.

Concerning the model for the animal sample, the biological indicator was represented by parallelepiped with dimensions LX (length), LY (width) and LZ (height) of 30mm, 2.0mm and 2.0mm, respectively (Figure 21). In order to simplify the issue, we considered the dielectric parameters of a muscle with a relative permittivity of 54 and a conductivity of 1.22S/m at 900MHz.

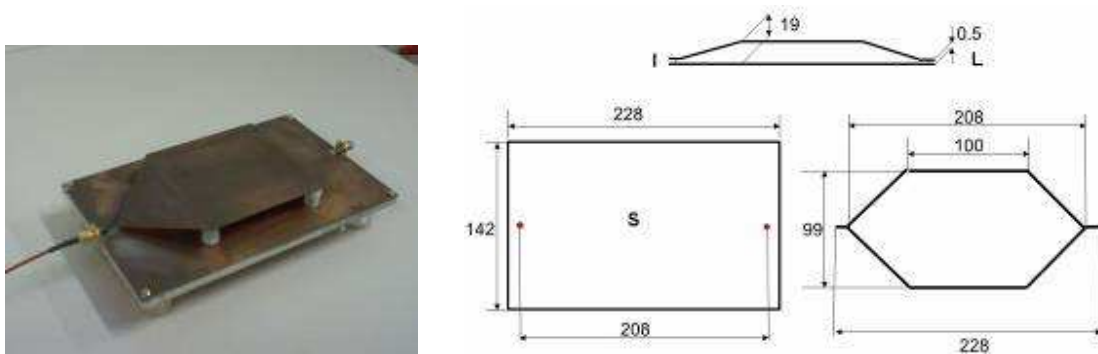

Figure 20. Configuration of the TEM cell mode of operation (left), and the dimensions of the TEM cell (right) (I: input; L: load; S: sample).

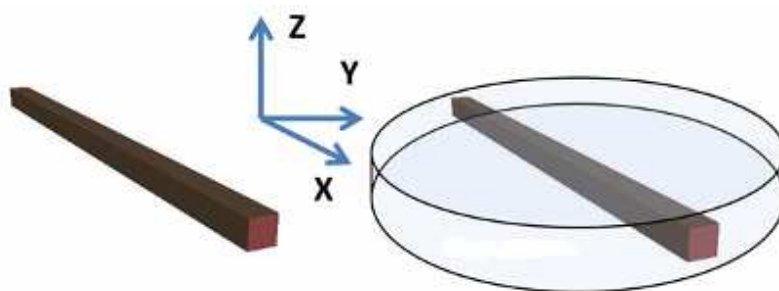

Figure 21. Model of the sample organisms for FEKO simulations.

Considering the random orientation of the sample (Figure 22), the specific power flux density of the field was $392.5mW/m^3$; for the mass density of the organism is $2.083g/m^3$, the power density corresponded to a specific absorption rate (SAR) of $0.20mW/Kg$. The power densities and calculated

SAR excluded thermal heating stress (WHO, 2000); however, the temperature inside the Petri dishes was measured at the beginning and at the end of the experiments, and no difference was observed.

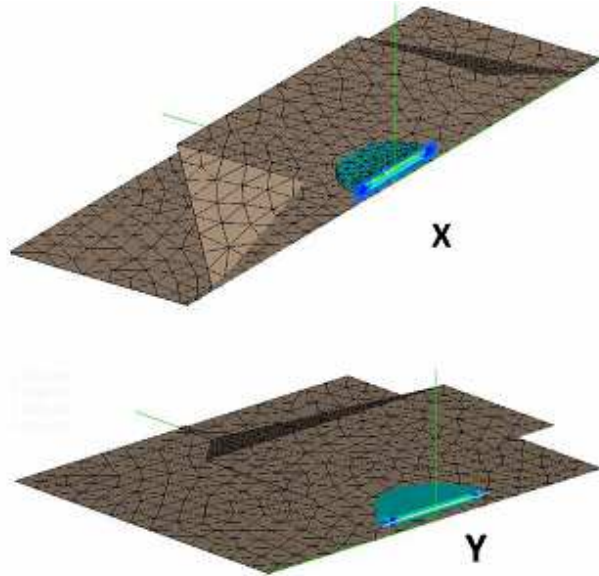

Figure 22. Configuration of the sample (indicator & water dish) inside the device. Longitudinal (X) and transversal (Y) section.

5.2. Comet assay

This relatively new method is considered a simple and quite rapid tool for the assessment of damage and repair in individual eukaryotic and prokaryotic cells as well, and many applications have been increasingly found in different fields, from toxicology to epidemiology (Collins et al., 1997a). The technique permits to quantify single and double strand breaks and alkali labile sites, expressed as strand breaks in DNA (Dhawan et al., 2008); some other lesions of DNA, like DNA cross-links and the assessment of DNA repair can be studied by modifying the standard protocol, thus adding specific antibodies and bacterial endonuclease/glycosidase enzymes (Speit and Hartmann, 2005).

Briefly, this approach involves lysis with detergent and high salts – after embedding cells in agarose – so that the DNA molecule can migrate under an electric field to the positive pole of an electrophoretic tank (Figure 23). After the staining step by using fluorescent dyes, different levels of damage are visualized at the microscope (Figure 24) by considering the comets formed after the electrophoresis step.

Materials and methods



Figure 23. Scheme of classic comet assay (from Liao et al., 2009).

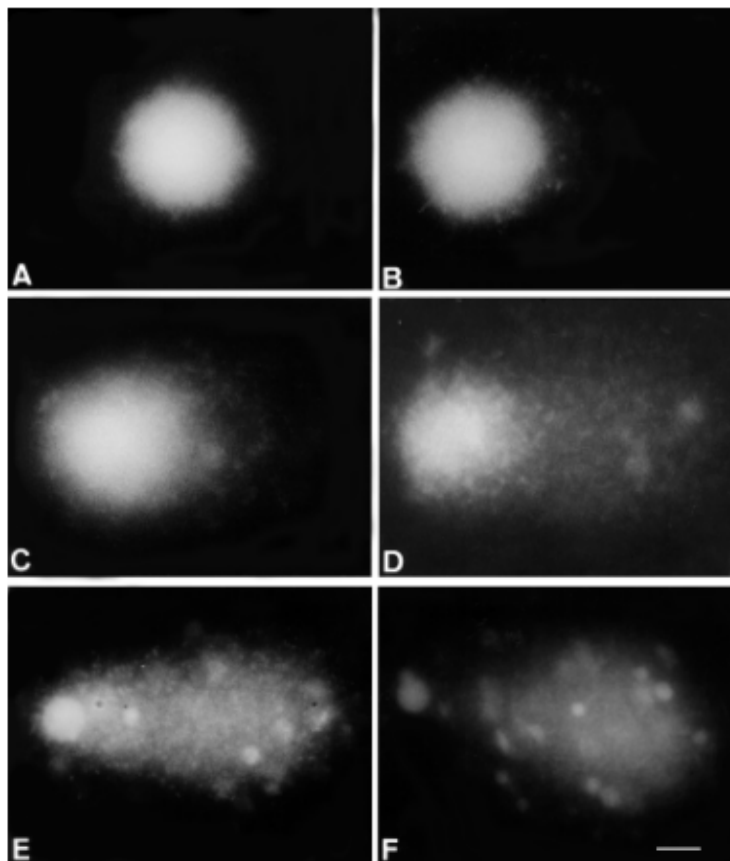

Figure 24. Different levels of damage from comet assay (from Silva et al., 2000).

Among the benefits by using this approach, it can be argued that this technique has a great sensitivity for detecting low levels of damage (one break per 10^{10} Daltons of DNA) (Gedik et al. 1992); moreover, the requirement of a small amount of cells (about 10^4 cells) per sample, the flexibility to use both

Materials and methods

proliferating and nonproliferating cells, ease of performing and the short time to complete the assay, make comet assay a reliable tool for the assessment of genotoxic damage (Dhawan et al., 2009).

Nevertheless, some drawbacks can be found; first of all, there are some troubles to detect high levels of genotoxicity, as the levels of genotoxicity tends to reach a plateau. Moreover, the fact that the user chooses a fixed number of cells to analyze the damage increases the likelihood of bias and, as a consequence, the variability of data from different users (McArt et al., 2009).

By comparing this technique with other approaches for the assessment of DNA, the analysis of the phosphorylation status of the minor histone H2AX has been demonstrated to be sensitive to double strand breaks, but the result is an average, rather than a response of a single cell, like in the comet assay (Rothkamm and Lobrich, 2003). Moreover, two different approaches have been used to assess the oxidative damage of DNA; the most common biomarker for the detection of oxidative stress is 8-oxo-7,8-dihydro-2'-deoxyguanosine (8-oxodGuo) by HPLC detection. However, a valid alternative is the use of a modified protocol of traditional comet assay procedure by introducing a specific enzyme formamidopyrimidine-DNA glycosylase (FPG) to convert 8-oxo-7,8-dihydroguanine (8-oxoGua) to apurinic sites, and subsequently measuring these sites as DNA breaks using the comet assay (Liao et al., 2009). Although modified comet assay cannot be used when the extend of damage is high, nevertheless, the enzymatic protocol of comet assay, generally given to estimate of 8-oxoGua, is several times precise than HPLC approach, and it is less likely to suffer of adding oxidation processes occurring during HPLC analysis (Liao et al., 2009).

Various models ranging from bacteria to human being have been developed, as it is explained in figure 25 (Dhawan et al., 2008); even invertebrates models, and especially very recent studies on *Eisenia fetida* are present in literature, thus providing coelomocytes as a valuable tool for assessing DNA damage (Di Marzio et al., 2005; Qiao et al., 2007); for worms feed the soil they live in, they have been used as bioindicators for the evaluation of the genotoxic potential of contaminants present in soil, such as polluted coke oven sites (Salagovic et al., 1996) or sediment samples from polluted river systems (Rajaguru et al., 2003).

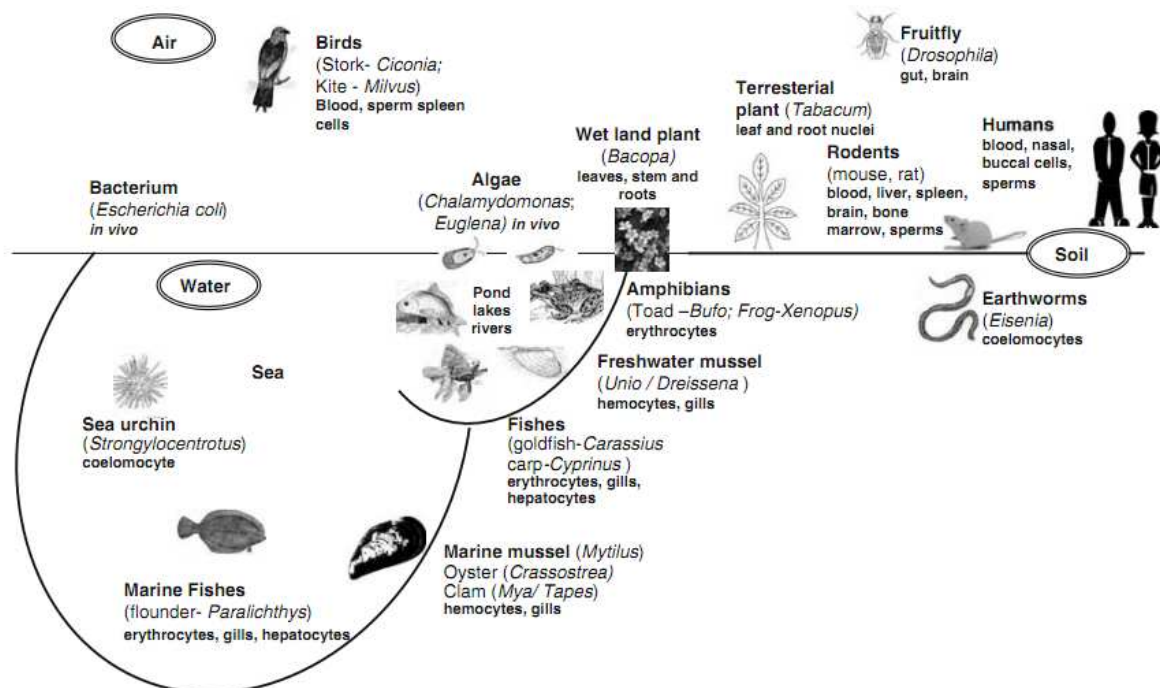

Figure 25. Schematic representation of the different uses of comet assay (from Dhawan et al., 2008).

Few studies were reported by using comet assay to measure the increase in single and double strand breaks after exposure to microwaves during *in vivo* experiments; Sakar et al. (1994) suggested breakage of DNA strands after exposure of mice to radiofrequency electromagnetic fields (2450MHz, power density of 1mW/cm²) for 2h per day over a period of 120, 150, and 200 days. Lai and Singh (1996) observed an increase of single and double strand breaks in brain cells of rats exposed for 2h to pulsed and continuous wave 2450MHz radiofrequency electromagnetic radiation. Nevertheless, Malyapa et al. (1998) did not confirm the previous observations, reporting that no significant differences were observed among the comet parameters from either the cerebral cortex or the hippocampus of sham-treated rats and those from the irradiated rats.

No attempt to study the genotoxicity on bioindicators caused by anthropic sources of radiofrequency and microwave electromagnetic fields, such as TV-radio broadcasting antennas and base transceiver stations (BTS) from mobile communications, has been performed, so far. Only a biologic indicator to assess the damage on DNA from extremely low frequency electromagnetic fields was considered as a valuable organism for field environmental exposure; indeed, Regoli et al. (2005) used the land snail *Helix aspersa* as a valuable organism to assess a large panel of biological responses, among which the comet assay after extremely low frequency electromagnetic fields exposure (50Hz) under both laboratory conditions and on field; the results showed an overall oxidative challenge caused by low frequency fields.

For the lacking of a valid biological indicator which reflects the induction of the genotoxic response of radiofrequency and microwave fields and the non-univocal results on damages on DNA after exposure to these physical agents, *Eisenia fetida* has been chosen to investigate this issue under controlled laboratory conditions and under realistic conditions of field environmental exposure.

The comet standard protocol was followed to detect whether a damage on DNA of coelomocytes from organisms exposed to microwave frequencies alone and in combination with a known genotoxic agent, i.e. UVC rays, could be observed or not. In addition, a modified approach of the standard protocol was chosen to identify a specific class of DNA lesion; in particular, endonuclease III (Endo III) to detect oxidized pyrimidines and formamidopyrimidine-DNA glycosylase (FPG) to identify the major purine oxidation product 8-oxoguanine as well as other altered purines was used. The modified comet assay protocol was also used to measure the DNA repair activity of cells when exposed to UVC rays alone and in combination with microwave fields, by using T4 endonuclease V for UV-induced lesions. The most relevant steps of comet assay standard protocol used during our investigation are described below.

5.2.1. Collection of cells

Three different methods were proposed to collect coelomocytes from the internal cavity of individuals. Electrical extrusion (Ville et al., 1997), by shortly stimulating animals (<1s) to 6V alternate current, and an ultrasound extrusion method (Hendawi et al., 2004), by introducing worms into an ultrasonic bath for a series of about 10 exposures of 2-3s each, were initially used for extrusion of cells. Finally, we adopted an ethanol extrusion method introduced by Eyambe et al. (1991) with slight modifications for collecting earthworms leukocytes; this technique is rapid, easy to perform protocol, non-invasive and guarantees a great amount of cells. In addition, it prevents the animals expelling their contents from their lower gut, thus making the performance more rapid. Briefly, individual earthworms were put into eppendorf tubes containing 1mL of extrusion medium for about 30s and their coelomocytes were obtained; immediately after extrusion, test tubes were kept on ice. The medium consisted of 10% ethanol in saline solution (0.90% NaCl) and 2.5mg/mL EDTA, adjusted to pH 7.5; cells were spontaneously excreted by animals, centrifuged (1500g, 4min., 4°C), washed with PBS buffer and put

on ice before comet assay. Samples were diluted with PBS in order to obtain approximately 10^4 cells; leukocytes from each worm were collected and processed separately for all assays.

5.2.2. Slide preparation

The assay was performed according to the original protocol of Singh et al. (1988) with some modifications in order to make it appropriate for coelomocytes. All steps were performed under red dim light in order to prevent additional damages on DNA.

The main goal of slide preparation is to ensure easily visualized comets with minimal background noise as well as to obtain uniform gels sufficiently stable for subsequent manipulation (Liao et al., 2009). Slides were pre-coated with 0.75% at 60°C of normal melting point agarose (NMA) prepared in phosphate-buffered saline (PBS 0.1M), and stored overnight at 4°C in a humidified slide chamber until use. Subsequently, 10µl of each diluted sample was added to 80µl of low melting point agarose (LMP) (0.56% in PBS) at 37°C and the cell suspension was rapidly spread on the slide, on the first agarose layer, using a coverslip. Care must be taken with the number of cells per visual field, as greater amount of cells can lead to an overlapping of comets, especially at high rates of DNA migration; on the other hand, higher agarose concentrations can affect the extent of DNA migration.

The slide was cooled on 4°C for 15 minutes for the LMP to solidify. Then, the coverslip was removed and slides immersed in a cold (4°C) lysis solution (NaCl 2.5M, Na₂EDTA 100mM, NaOH 300mM, Tris base 10mM, SLS 34mM, pH10) with 1% Triton X-100 and 10% DMSO added just before use. Cells were kept at 4°C in the dark for 10min to lyse the cell.

5.2.3. Electrophoresis

Slides were removed from the lysis solution, and they were gently washed with PBS, drained and placed side by side on a horizontal electrophoresis tank. Slides were covered with a chilled fresh alkaline buffer (NaOH 300mM, EDTA 1mM) at 4°C and pH>13 in order to detect double and single strand breaks as well as alkaline-labile sites (Hartmann et al. 2003). Before the electrophoresis step, slides were left in the solution for 25 minutes to allow the unwinding of DNA. Electrophoresis was carried out at a low temperature (4°C) for 15 minutes at 1V/cm and 300mA. After electrophoresis, slides were gently washed in a neutralization buffer (400mM Tris; pH 7.5) to remove alkali and detergents. Under the step of neutralization, DNA strands separate by alkaline treatment, and the comet head readily renatures due to its intact structure with supercoiled loops, while the DNA in tail remains single-stranded (Liao et al., 2009). Finally, 20µl of DAPI (5µg/mL) was added to each slide, covered with a coverslip and stored at 4°C.

5.2.4. Slide scoring

Slides were examined at 40x magnification with a fluorescence microscope (Zeiss, Axioplan 40) to the image analysis system (Comet Imager, MetaSystems, Germany). Images of 50 randomly selected cells at 40X magnification and a total of 100 cells per slide were analyzed. Tail moment (TM) was used as the main genotoxic parameter to quantify the extent of strand breaks. Tail Moment is calculated as measure of tail length by the measure of DNA in the tail. TM is a widely used parameter in comet assay (Liao et al., 2009), for it has been demonstrated to be dose-dependant linear with increasing levels of toxic agent (McKeown et al., 2003).

In order to standardize the comet assay protocol for *E.fetida* coelomocytes, different concentrations of H₂O₂ (0, 3, 10, 30µM, respectively) were diluted in PBS. *In vitro* cells exposures were conducted by

exposing slides to 50 μ L of hydrogen peroxide for 10 min at 4°C, before lysis. All the steps of comet assay were performed as described above.

5.3. Oxidative damage

In order to assess the potential oxidative damage caused by microwave electromagnetic exposure, two base excision repair enzymes, i.e. endonuclease III (Endo III) and Formamidopyrimidine DNA glycosylase (FPG) were used in combination with a modified comet assay protocol.

Endonuclease III has been first identified in *E.coli*, introducing strand scission in the DNA molecule after UV exposure (Radman, 1976) and X-irradiated DNA (Boiteux et al., 1984); now, it has been observed that this enzyme has a wide spectrum of action, and a great variety of substrates have been identified for Endo III (Figure 26). The common feature of substrates for this repair enzyme results in the affinity for oxidative damage of pyrimidines, i.e. thymine or cytosine.

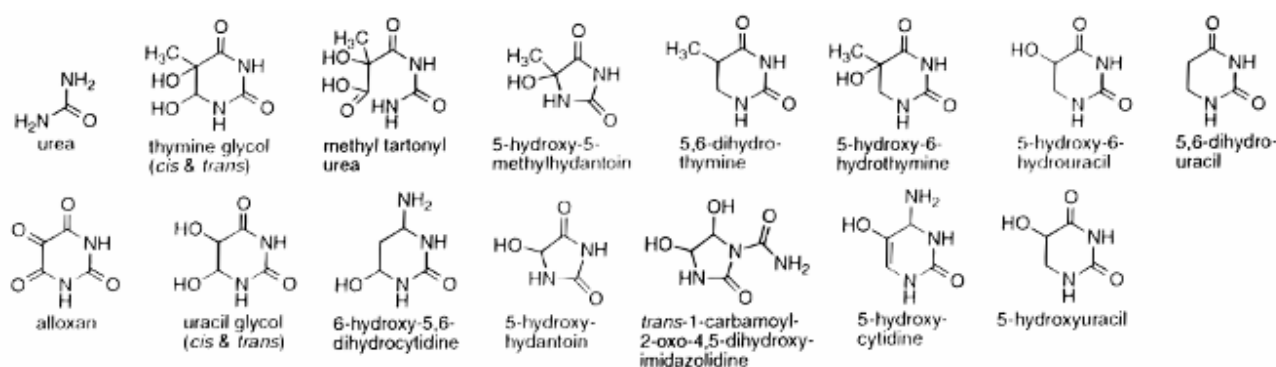

Figure 26. Substrates for Endo III activity (from David and Williams, 1998).

Endonuclease III has been shown to have both N-glycosylase and apurinic/aprimidinic (AP) endonuclease activities (Kow and Wallace, 1987); in fact, the N-glycosylase activity releases damaged pyrimidines from double stranded DNA, generating an apyrimidinic (AP) site. Then AP-lyase activity of the enzyme cleaves 3' to the AP site leaving a 5' phosphate and a 3'-phospho- α , β -unsaturated aldehyde (David and Williams, 1998).

The other enzyme, FPG, is less specific than Endo III, for it is involved in a wide spectrum of substrates. FPG catalyzes the removal of N7-methylguanine, which can block DNA synthesis and, finally, it may lead to deleterious effects to cell (Laval et al., 1990); moreover, the protein is involved in removing a broad spectrum of oxidized purines, such as 2,6-diamino-4-hydroxy-5N-methylformamidopyrimidine (FapyGua) and 4,6-diamino-5-formamidopyrimidine (FapyAde), which are mainly produced by ionizing radiations (Boiteux et al., 1992). FPG also removes 7,8-dihydro-8-oxoguanine (8-oxoG) residues, which is one of the most common oxidative lesions in DNA and its presence results in DNA mutations (Figure 27) (David and Williams, 1998).

FPG protein is also able to excise various products of pyrimidine oxidation, such as 5-hydroxycytosine and 5-hydroxyuracil (Hatahet et al, 1994) and *in vivo* studies demonstrated that the protein has an antimutator effect, preventing G:C \rightarrow T:A spontaneous transversion (Saparbaev et al., 2002).

FPG acts both as N-glycosylase, generating an apurinic site and catalyses the nicking of both the phosphodiester bonds 3' and 5' of apurinic or apyrimidinic sites in DNA. Therefore, the base-free deoxyribose is replaced by a gap limited by 3'-phosphate and 5'-phosphate ends (Bailly et al., 1989), finally catalysing a β -elimination reaction which is immediately followed by a δ -elimination.

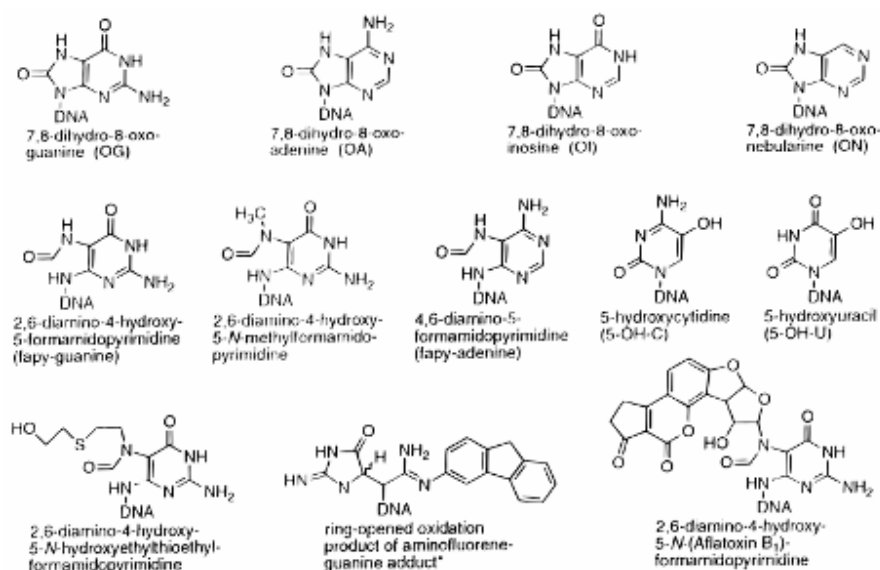

Figure 27. Substrates for FPG protein (from David and Williams, 1998).

5.3.1. Modified comet assay for oxidative damage

The assessment of oxidative damage on the DNA molecule was guaranteed by the combination of two specific enzyme, FPG and Endo III digestion with a modified protocol of comet assay; the enzymes are specific for oxidized purines and pyrimidines, respectively. After preliminary investigations by using hydrogen peroxide to standardize the assay protocol, coelmoocytes were analyzed after organisms were exposed to 900MHz EMF and left in their native soil for different times of recovery (t0, t60, t120, t1440). Under the conditions of modified protocol of comet assay, the two enzymes introduce additional strand breaks, specifically at sites of oxidized purines and pyrimidines; therefore, a balance between the input of damage and repair was represented. Briefly, after lysis step, slides were washed three times with enzyme reaction buffer (40mM Hepes, 0,1M NaCl, 0,5mM Na₂EDTA, 0,2mg/mL Bovine Serum Albumine (BSA), pH 8) and placed in reaction enzyme buffer for 5 minutes. Then, 50µl of buffer (control) or enzyme (0.5U/slide for both FPG and EndoIII, (Euroclone, Italy) dilution 1:1000) in buffer was transferred to the slides. Next, slides were kept at 37°C for 30 and 45 minutes for FPG and Endo III, respectively and, finally kept at 4°C for 30 minutes, to prevent problems of diffusion of the genetic material and drying or cracking of the agarose layers. Then, slides were washed three times with PBS and kept in staining jar, for 2 minutes each. The following steps were identical to the aforementioned steps of standard comet assay protocol. After visual scoring, data were collected by considering both slides treated with enzyme and with buffer alone.

5.4. UVR genotoxicity

As some investigations reported an increase in genotoxicity of some chemicals and physical agents, such as UVC rays, in combination with microwave radiation exposure (Ruediger, 2009), we studied the mutual relationship between these two physical agents.

UV radiations cover only a little part of the electromagnetic spectrum, their wavelengths ranging between 100nm to 400nm. Even in this portion of the spectrum, the biological effects on the environment tend to be various, according to the specific wavelength; for this reason, UV radiations were divided into three regions. The notion to group UV rays into three different spectral regions was

Materials and methods

first argued at the Copenhagen meeting of the Second International Congress on Light in 1932. It was recommended that the spectrum was divided into the following regions:

UVA 400–315nm;

UVB 315–280nm;

UVC 280–100nm.

The longer wavelength radiations, i.e. UVA and UVB, are mostly studied because solar UV radiation can produce deleterious effects on human health, for available epidemiological observations indicated that solar UV is the major responsible of skin cancer (Pfeifer et al., 2005) and non-melanoma skin cancer (de Gruijl, 1999). Ultraviolet radiation induces dramatic effects also in prokaryotic bacteria, lower and higher plants and animals, such as reduction in growth and survival, protein destruction and photo-inhibition of photosynthesis (Sinha and Häder, 2002). UVC radiation is not considered important for an ecological point of view, for it is quantitatively absorbed by oxygen and ozone in the Earth's atmosphere, while the most significant effects on biota from solar UV are attributed to UVB light, which is easily absorbed by cellular DNA and can generate DNA photoproducts (Schuch and Menck, 2010). Nevertheless, for the maximum levels of absorption by DNA is 260nm, UVC rays are considered the most effective physical agent to produce DNA photoproducts; in fact, they mainly produce two types of damage, i.e. cyclobutane pyrimidine dimers (CPDs) (Figure 28) and pyrimidine (6–4) pyrimidine photoproducts(6–4PPs) (Mitchell and Karentz, 1993) (Figure 29).

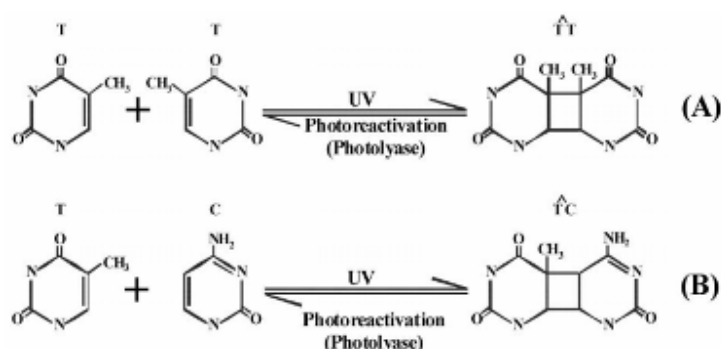

Figure 28. (A) thymine-thymine cyclobutane-pyrimidine dimer and (B) thymine-cytosine dimer and their photoreactivation (from Sinha and Häder, 2002).

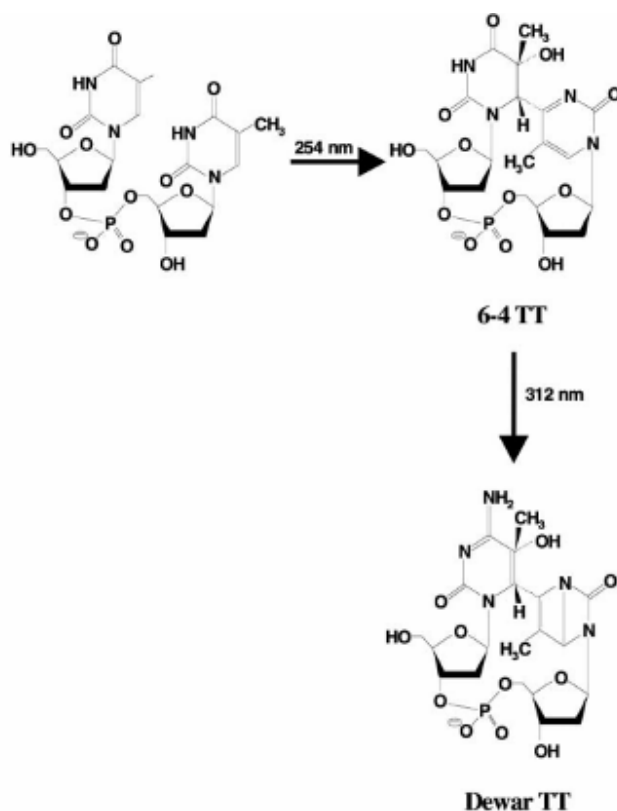

Figure 29. Formation of 6-4 photoproducts and their Dewar isomers (from Sinha and Häder, 2002).

These lesions produce peculiar mutations, named C–T transitions, by misincorporation of the adenine opposite to cytosine during replication; dimers can form between two adjacent pyrimidines (T-T or C-T), but damage can be reverted by the photolyase enzyme that specifically binds to CPDs (CPD photolyase) (Kim et al., 1994).

6-4 photoproducts are formed at 5'-T-C-3', 5'-C-C-3', 5'-T-T-3', but not at 5'-C-T-3' sites in DNA (Sinha and Häder, 2002), and they are potentially mutagenic. Since photoisomeration is most efficient around 320 nm, UVB and UVA light should produce a great amount of Dewar isomers (Taylor et al., 1990).

Finally, a minor damage product caused by UVC results in indirect oxidative damage, specifically in the formation of 8-oxo-7,8-dihydro-2'-deoxy-guanosine(oxo8 dG) (Ottaviani et al., 2002). In fact, after the absorption of photons, energy can be transferred to molecular oxygen, thus generating reactive oxygen species (ROS), such as hydroxyl radicals, and singlet oxygen which can interact with DNA (Ottaviani et al., 2002).

It is important to note that lesions resulting in DNA-induced UV exposure do not produce directly breaks, and repair pathways do not directly reverse DNA damage, but they replace the damaged DNA with new nucleotides (Sancar, 1996). In particular, two categories of DNA repair mechanisms are involved, i.e. base excision repair (BER) and nucleotide excision repair (NER).

The first group of excision repair mechanisms is mainly involved in recognizing endogenous damage of DNA induced by reactive oxygen species, hydrolysis and other metabolites that can interact with the structure of DNA (Sinha and Häder, 2002); depending on the specific damage, different DNA glycosylases are involved to remove damage. The principal steps of BER pathway are resumed in Figure 30. Briefly, the enzyme cleaves the glycosidic bond between the base and the two parts of

deoxyribose of the nucleotide residues (David and Williams 1998); then the apurinic/aprimidinic site (AP) is removed by an endonuclease or a lyase, which cleaves 5' or 3' DNA strand, respectively. Finally, a DNA polymerase fills the resulting gap (Sakumi et Sekiguchi, 1990).

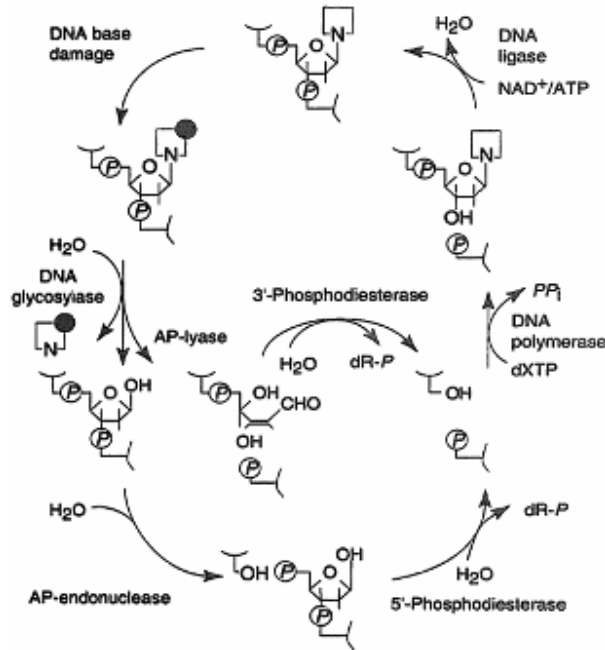

Figure 30. Main steps of BER pathway (from Seeberg et al., 1995).

In addition to glycosylases, also endonucleases are involved in base excision repair mechanisms. They recognize and generate strand breaks in correspondence with the site of the pyrimidine dimers, which are the most abundant and probably the most toxic lesions resulting in UV exposure (Sinha and Häder, 2002). Endonucleases typically cleave the *N*-glycosylic bond of the 5' pyrimidine of the dimer and break the phosphodiester bond 3' to the resulting abasic site (Seeberg et al., 1995).

Nucleotide excision repair (NER) system is involved in a wide spectrum of DNA damages, including CPDs and 6-4PPs and it is conserved in eukaryotes (Thoma, 1999). The main steps of NER pathway are represented in figure 31; during the first step XPC-hHR23B proteins are involved in the DNA-damage recognition, by creating a complex with the DNA distortion. Then, an open complex is formed by XPA (Rad14), RPA (Rfa) and the general transcription factor TFIIH; in the third step, the excision step is guaranteed by nuclease activity. Finally, the gap is filled by DNA synthesis and closed by DNA ligase (Thoma, 1999).

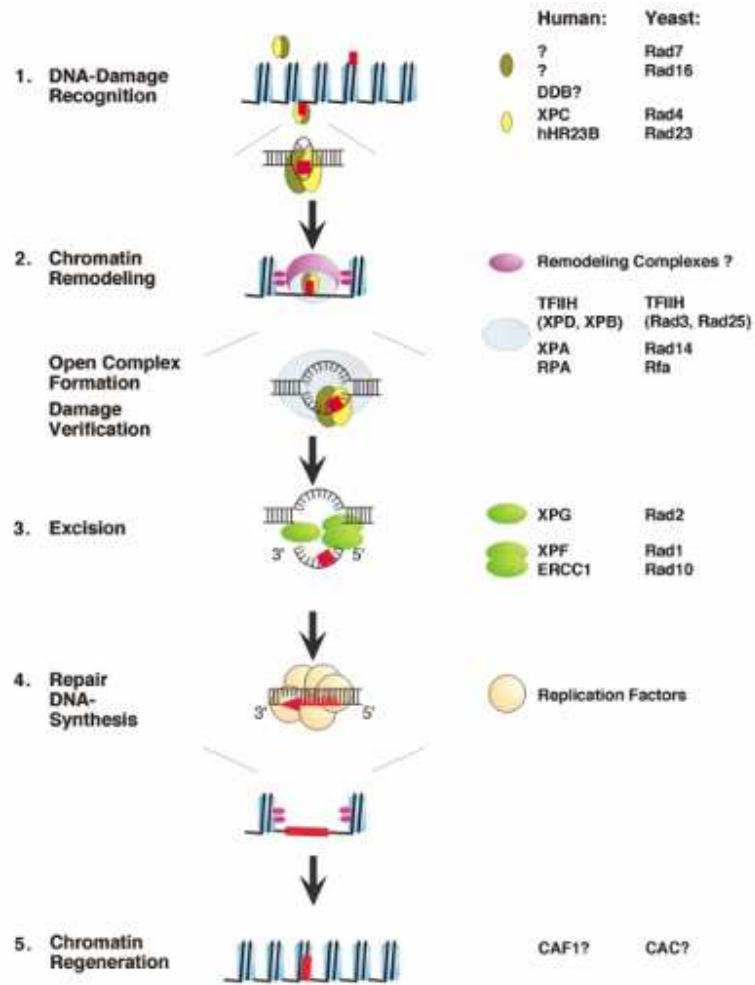

Figure 31. Schematic representation of the NER mechanism (from Thoma, 1999).

5.4.1. UVC exposure setting

Earthworms were radiated with a 254nm UV germicidal lamp (Philips bulb TUV 55W HO SLV), with a dosage of 13.54KJ/m²; the reference density power was deduced by previous investigations (Sicolo, 2004).

For the observation of the genotoxic effects of UVC rays, earthworms were put one per glass Petri dish (30.8mm diameter) containing 3mL of distilled water. For each experiment, control animals were kept in the same conditions than exposed organisms.

5.4.2. Repair enzyme - T4 Endonuclease V

In order to assess the influence of electromagnetic fields on DNA repair mechanisms of UVC, T4 endonuclease V enzyme was used. Endonuclease V (Epicentre Biotechnologies, Madison, Wisconsin) is one of the most widely studied enzymes and its purifications and proposed mechanisms of action are present since 1970 (Yasuda and Sekiguchi, 1970). This enzyme was originally purified from T4-infected *Escherichia Coli* and it was observed that the extract contained an enzymatic activity that

specifically released nucleotides containing pyrimidine dimers from UV-irradiated DNA (Dodson and Lloyd, 1989). Endonuclease V is specific for cyclobutane pyrimidine dimers, and thymidyl (3'-5')-thymidine dimers were demonstrated to be the best substrates for the enzyme (Figure 32) (Gordon and Haseltine, 1980). On the contrary, no activity of enzyme has been shown for the other important class of damage from UV, such as Dewar dimer photoproducts (David and Williams, 1998). Nevertheless, 4,6-diamino-5-formamido pyrimidine (fapy-adenine), an hydroxyl radical-induced product of adenine, was identified as a new substrate for this enzyme, for it was observed to be removed by T4 endonuclease V (Dizdaroglu et al., 1996). FapyAde is a major OH-induced product of the adenine moiety in DNA, and it is strictly related to oxidative DNA damage (David and Williams, 1998); nevertheless, it has been found to be approximately at rate of 1-3% that of the incision at UV-radiation-induced cyclobutane pyrimidine dimers (Dizdaroglu et al., 1996).

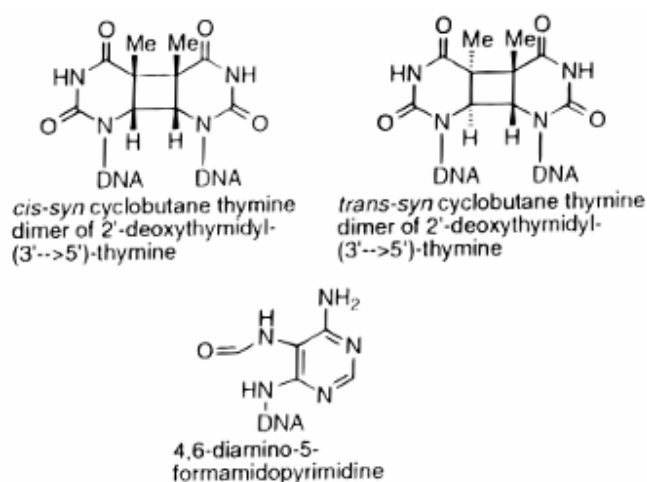

Figure 32. The substrates for T4-endonuclease V activity (from David and Williams, 1998).

The structure and the mechanism of action of T4 endonuclease has been widely characterized (Dalhus et al., 2009; Iwai et al., 1995). Briefly, it has been shown that the enzyme is able to cleave the N-glycosyl bond of 5'-pyrimidines at dimers of adjacent pyrimidines with subsequent AP endonuclease activity to give phosphodiester bond cleavage between the dimerized pyrimidines (Figure 33).

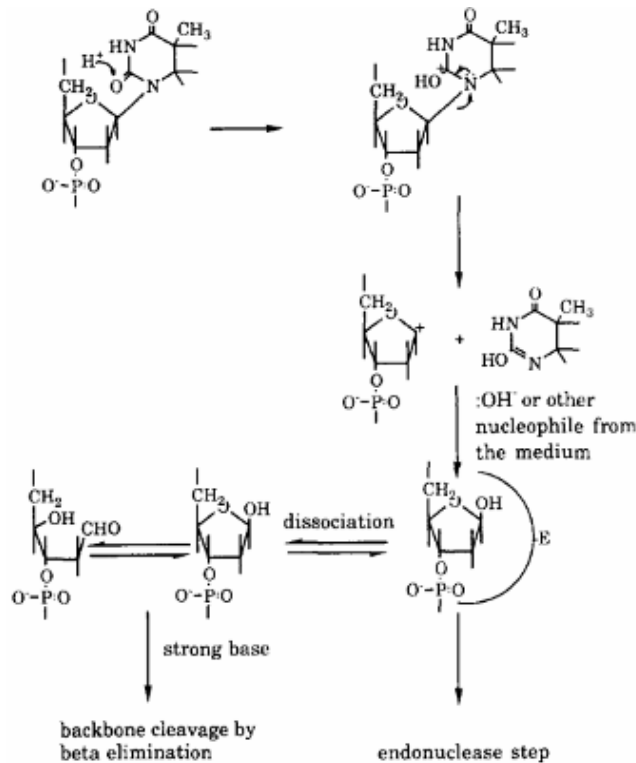

Figure 33. Initial steps of mechanism of endonuclease V (from Dodson and Loyd, 1989).

5.4.3. Modified comet assay for T4 Endonuclease V

Removal of cyclobutane pyrimidine dimers was detected by a combination of specific enzyme, T4 endonuclease V digestion with a modified protocol of comet assay; the enzyme is specific for cyclobutane pyrimidine dimers (Gallagher and Duker, 1986). T4 endonuclease V recognizes the lesion in DNA strand and, in a two-step reaction, cleaves the glycosyl linkage of the 5'-side thymidine and the phosphodiester linkage, thus amplifying the amount of breakages. Briefly, after lysis step of comet assay, slides were washed three times with T4 endonuclease buffer (10mM EDTA, 10mM Tris, 0.9% NaCl, pH 8); then, 50µl of buffer (control) or T4 endo V (4U/slide) in buffer was transferred to slides. Next, slides were kept at 37°C for 45 minutes and, finally kept at 4°C for 30 minutes, to prevent problems of diffusion of the genetic material and drying or cracking of the agarose layers. Then, slides were washed three times with PBS and kept in staining jar, for 2 minutes each. The following steps were identical to the aforementioned steps of standard comet assay protocol. After visual scoring, data were collected by considering both slides treated with enzyme and with buffer alone.

5.5. Field exposure

We also investigated the genotoxicity caused by exposing organisms to anthropic sources of radiofrequency-microwave electromagnetic fields in the city of Milan.

Milan is one of Italy's most involving cities in radio-tv antennas and trasmitters for mobile communications; in fact, 1,158 BTS and 97 radio-tv sources are present in the district of Milan, thus corresponding to a density (source per Km²) of 6.37 and 0.53, respectively (http://ita.arpalombardia.it/ita/RSA_2008-2009/08-radiazioni/080201tab08_08.pdf). In particular, the

Materials and methods

amount of base stations for mobile communication per Km² is higher with respect to that found in other important Italian cities such as Turin (0.35), Rome (0.47), and Florence (0.36).

Concerning the limit values for public exposure to electromagnetic fields, ranging between 100 kHz and 300 GHz, the Italian decree promulgated in 2003 (Italian DPCM, 2003) reports that electric field cannot overwhelm the exposure limits (20V/m, for open field exposure) and the attention levels (6V/m, for exposures inside gambling areas, schools and buildings, where people stay for more than 4 hours).

For this reason, we chose three points of sampling into the city of Milan-Italy, where the electric field was relatively high and presented different values, as well. In addition, one negative control site (where the electric field detected was very low and absent, in some cases) was considered. A preliminary investigation, considering different hot spots of electromagnetic field in the city, was performed; finally, the sampling sites were chosen by taking into account the list of anthropic sources from ARPA Lombardia (2005) that overwhelmed the limit values of the Italian law. One main source of electromagnetic field for each point of sampling was identified. The first area of investigation was close to a multiple source of radio and tv broadcasting antennas and base transceiver stations built on a roof of a skyscraper (see table 7 for the list of sources) and the other two points of monitoring were settled near a broadcasting and BTS tower (see table 8 for the list of sources) (Figure 34).

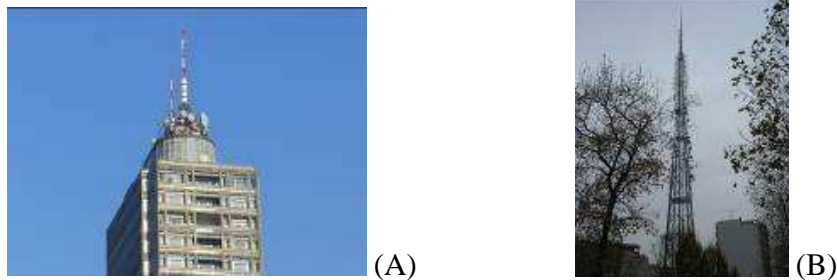

Figure 34. (A) Multi-source antennas from the first point of investigation and (B) radio-TV broadcasting antennas and BTS located in second area of monitoring.

Owner	Name of the source	Frequency type
ANTENNA 40 S.r.l.	TELEMONDO	VHF
PRIMARETE LOMBARDIA S.p.A.	PRIMARETE LOMBARDIA	UHF
MONTESTELLA S.p.A.	RADIO MONTESTELLA/BUM BUM/RADIO SPAZIO ZERO	FM
RADIO ITALIA S.p.A.	RADIO ITALIA SOLO MUSICA ITALIANA	FM
RADIO ITALIA S.p.A.	RADIO ITALIA SOLO MUSICA ITALIANA	PONT
Radio Sound International Soc. Coop. a r.l.	RADIO SOUND INTERNATIONAL	FM
MEDIATECH S.r.l.	Radio SuperHit - Radio Milano	FM
MEDIATECH S.r.l.	Radio SuperHit - Radio Milano	FM
PUBLIAUDIO S.r.l.	RADIO CUORE	FM
TECNINVEST S.r.l.	LATTEMIELE VARESE	FM
SEDIV S.p.A.	STUDIO NORD TV	VHF

Table 7. List of the electromagnetic sources present on roof of the building in Via Casati (close to Piazza della Repubblica) (point of investigation 1). PONT: radio link; FM: frequency modulation; VHF: very-high frequency; UHF: ultra-high frequency; GSM: global system for mobile communication. (from CASTEL database, ARPA Lombardia <http://cartografia/castel/home/home.asp>).

Materials and methods

Owner	Name of the source	Frequency type
NUOVA RADIO S.p.A.	Radio 24 Il Sole 24 Ore	PONT
TECNINVEST S.r.l.	LATTEMIELE VARESE	FM
R.T.I. - Reti Televisive Italiane S.p.A. (Gruppo Mediaset)	CANALE 5 [A] / ITALIA 1 [B] / RETE4 [C]	TELC
EUROPA TV S.p.A.	SportItalia	UHF
SUGARNET S.r.l.	RADIOMILANO1	FM
PIRENEI S.r.l.	TELE RITMO	VHF
VIRGIN RADIO ITALY S.p.A.	VIRGIN RADIO	PONT
VIRGIN RADIO ITALY S.p.A.	VIRGIN RADIO	PONT
VIRGIN RADIO ITALY S.p.A.	VIRGIN RADIO	PONT
RADIO CLASSICA S.r.l.	RADIO CLASSICA	FM
PUBLIAUDIO S.r.l.	RADIO CUORE	PONT
Assoc. RADIO MARIA	RADIO MARIA	FM
Rtl 102.5 Hit Radio S.r.l.	RTL 102.5	FM
PIRENEI S.r.l.	TELE RITMO	VHF
VODAFONE Omnitel N.V.	VODAFONE Omnitel	GSM
VODAFONE Omnitel N.V.	VODAFONE Omnitel	GSM
VODAFONE Omnitel N.V.	VODAFONE Omnitel	GSM
VODAFONE Omnitel N.V.	VODAFONE Omnitel	DCS
VODAFONE Omnitel N.V.	VODAFONE Omnitel	DCS
VODAFONE Omnitel N.V.	VODAFONE Omnitel	DCS
SUGARNET S.r.l.	RADIOMILANO1	PONT
LIFEGATE RADIO S.p.A.	LIFEGATE RADIO STATION - RADIO PAVIA	PONT
VODAFONE Omnitel N.V.	VODAFONE Omnitel	UMTS
VODAFONE Omnitel N.V.	VODAFONE Omnitel	UMTS
VODAFONE Omnitel N.V.	VODAFONE Omnitel	UMTS
ADIERRE PLANET S.n.c.	RADIO PLANET	FM
RADIANT S.p.A.	GAMMA RADIO	FM
ARTOSCANA S.r.l.	RADIO DOCTOR DANCE NORD	PONT
MULTIMEDIA SAN PAOLO S.r.l.	TELENOVA	UHF
NOVARADIO A S.r.l.	RADIO MARCONI	FM
WIND TELECOMUNICAZIONI S.p.A.	WIND	DCS
WIND TELECOMUNICAZIONI S.p.A.	WIND	DCS
WIND TELECOMUNICAZIONI S.p.A.	WIND	DCS
ELITE S.r.l.	RADIO MILLENNIUM	FM
PRIVERNO S.r.l.	RADIO CUORE 2	FM
UNITEDCOM S.r.l.		UHF

Table 8. List of the electromagnetic sources present at tower of San Galdino (points of investigation 2 and 3). PONT: radio link; FM: frequency modulation; TELC: telecommunication; VHF: very-high frequency; UHF: ultra-high frequency; GSM: global system for mobile communication; DCS: digital cellular service; UMTS: Universal Mobile Telecommunication System. (from CASTEL database, ARPA Lombardia).

The third area of interest, as a negative control point, was close to Università degli Studi di Milano-Bicocca where a low power was detected.

The points of sampling were chosen in order to have a far field condition, thus considering the electromagnetic field as a plane wave. For this reason, the areas of investigation were far enough from the main sources of electromagnetic power to satisfy the condition of far field ($S = D^2 / (4\lambda)$), where D is

the maximum overall dimension of the source and λ is the wavelength) (Figure 35). In addition, some precautions were taken to minimize the influence of other variable that could interfere with the measure of the electromagnetic field.

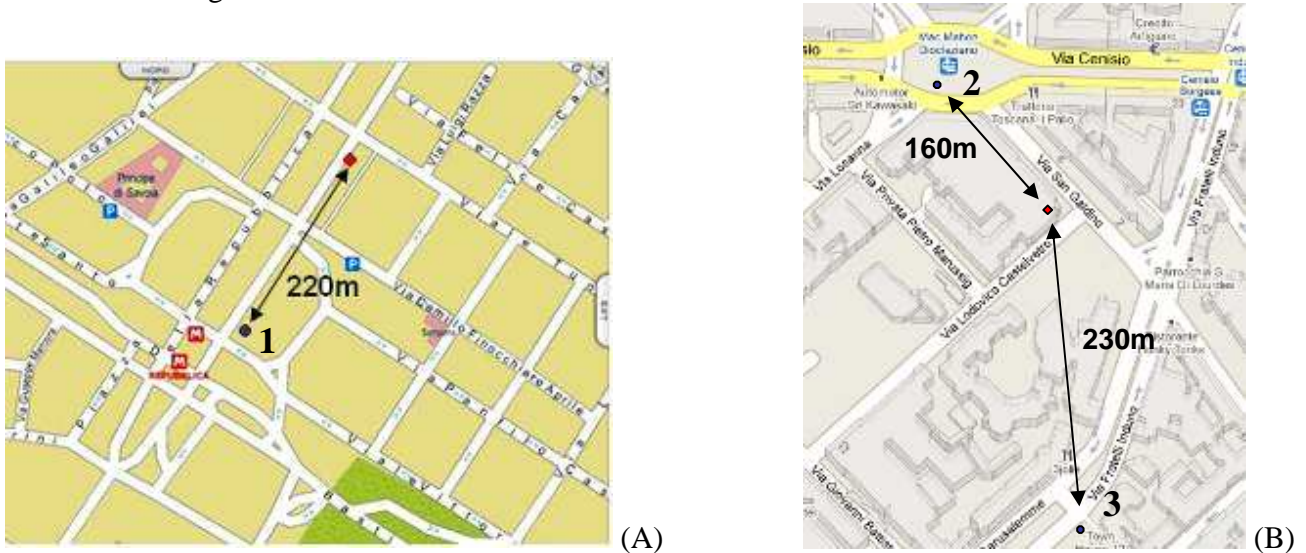

Figure 35. (A) First point of observation, close to Piazza della Repubblica and (B) second area of study close to Via San Galdino. The points of sampling and the source of RF are shown in blue circles and red squares, respectively. An additional area with no sources of EMF was chosen close to University of Milano-Bicocca.

The experimental conditions for field exposure were close to those of the laboratory approach. Briefly, organisms were put in Petri dishes containing 3mL of distilled water at 1.5m over the ground. Animals were maintained at a distance from anthropic sources in order to consider electromagnetic field as a plane wave. Controls were put into a metal cage, which sheltered from EMFs; both exposed and control animals were protected from direct solar exposure in order to prevent any additional DNA damage. Earthworms were exposed to human sources of electromagnetic fields, and coelomocytes were immediately collected by using the extrusion solution and kept on ice for comet assay. Contextually with the exposure, the electric field from anthropic sources was measured according to the suggestions of Anglesio (2000) and CEI (2001). In particular, the worker had to stay 3-4 metres far from the probe for not influencing the detection of the signal, and the probe itself had to be placed far from metallic objects, like cars or streetlights. A far field directional isotropic probe (FM100, Spin Electronics Torino, Italy) which is able to detect the electromagnetic field in a range of frequency within the interval 500KHz – 3GHz was used during the field exposure.

In order to study the possible influence of other environmental parameters on the response of bioindicators that might confound the interpretation of the data, we also considered some important variables, nitrogen dioxide (NO₂), ozone (O₃), sulfur dioxide (SO₂), benzene (C₆H₆), expressed as micrograms per cubic meter, carbon monoxide (CO) expressed as milligrams per cubic meter, polycyclic aromatic hydrocarbons, PAHs, in fine particles PM_{2.5} (PAH_{2.5}) expressed as nanograms per cubic meter and air temperature (C°). All the variables were collected from the Lombardy Regional Environmental Protection Agency (ARPA Lombardia) data archives (http://ita.arpalombardia.it/ITA/qaria/doc_Richiesta_Dati.asp) and the values of variables were referred to the interval of sampling.

6. STATISTICAL ANALYSIS

Data were statistically analyzed by Statgraphic Centurion XV software for Windows (Statpoint Technologies, Inc, VI, USA) and Prism for Windows (version 4.0, Graph Pad Software, Inc, CA, USA). Student's *t*-test for two-sample comparison or ANOVA and Duncan test for multiple sample comparison were applied when normality and homogeneity of variance in several distributions of investigated parameters were satisfied. Non normal data were log-transformed to attain normality, thus allowing the application of parametric statistics ANOVA or they were evaluated by non-parametric Mann-Whitney test or Kruskal-Wallis test coupled with Dunn's tests for two or multiple sample comparison, respectively. In order to model the relationship among the dependent and independent variables and to measure the strength of the relationship, principal component analysis (PCA) before multiple regression analyses was performed. In the multiple regression analysis the selection of independent variables was performed using a backward or forward stepwise regression method.



7. RESULTS

7.1. Results from laboratory exposure

7.1.1. 900 MHz electromagnetic field exposure

Preliminary experiments to verify the suitability of the modified alkaline comet protocol by Singh et al. (1988) (see above in materials and methods) for *E.fetida* were assessed by using a known genotoxic agent, hydrogen peroxide (Merck, Germany), and exposing coelomocytes directly to three concentrations of hydrogen peroxide – 3, 10 and 30 μ M, respectively; a significant increase in Tail Moment with respect to controls were observed at 10 and 30 μ M (Figure 36).

Concerning the results after the exposure of organisms to electromagnetic field source (expressed as differences between exposed and respective controls, Δ TM), figure 37 shows the genotoxic parameters, Tail Moment and Tail Moment Olive (defined as the product of the tail length and the fraction of total DNA in the tail), of coelomocytes at different times of recovery. Both Tail Moment and Tail Moment Olive at 2 hours after exposure (Δ TM=2.74 \pm 0.41 and Δ TMO=1.47 \pm 0.21, respectively) were significantly lower than t0 (Δ TM=6.63 \pm 0.70 and Δ TMO=4.40 \pm 0.43) and t30 (Δ TM=6.49 \pm 0.68 and Δ TMO=4.43 \pm 0.38), in which the maximum values of the genotoxic parameters were observed. Moreover, the level of damage at 24 hours after exposure was lower than controls. So, it can be concluded that a transient breakage of DNA was involved during the exposure of indicator species to microwaves under laboratory conditions and that the level of damage seemed to be completely repaired within 24 hours from the microwave exposure.

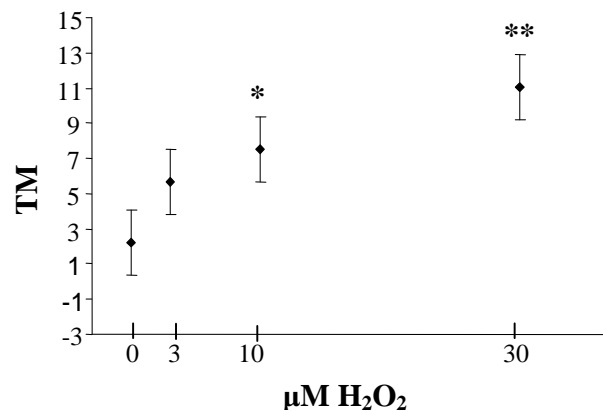

Figure 36. Tail Moment (TM) in coelomocytes after hydrogen peroxide exposure. Bars represent the standard error.

* As compared with control, $p < 0.05$. Kruskal-Wallis test followed by Dunn's test.

** As compared with control, $p < 0.001$. Kruskal-Wallis test followed by Dunn's test.

Results

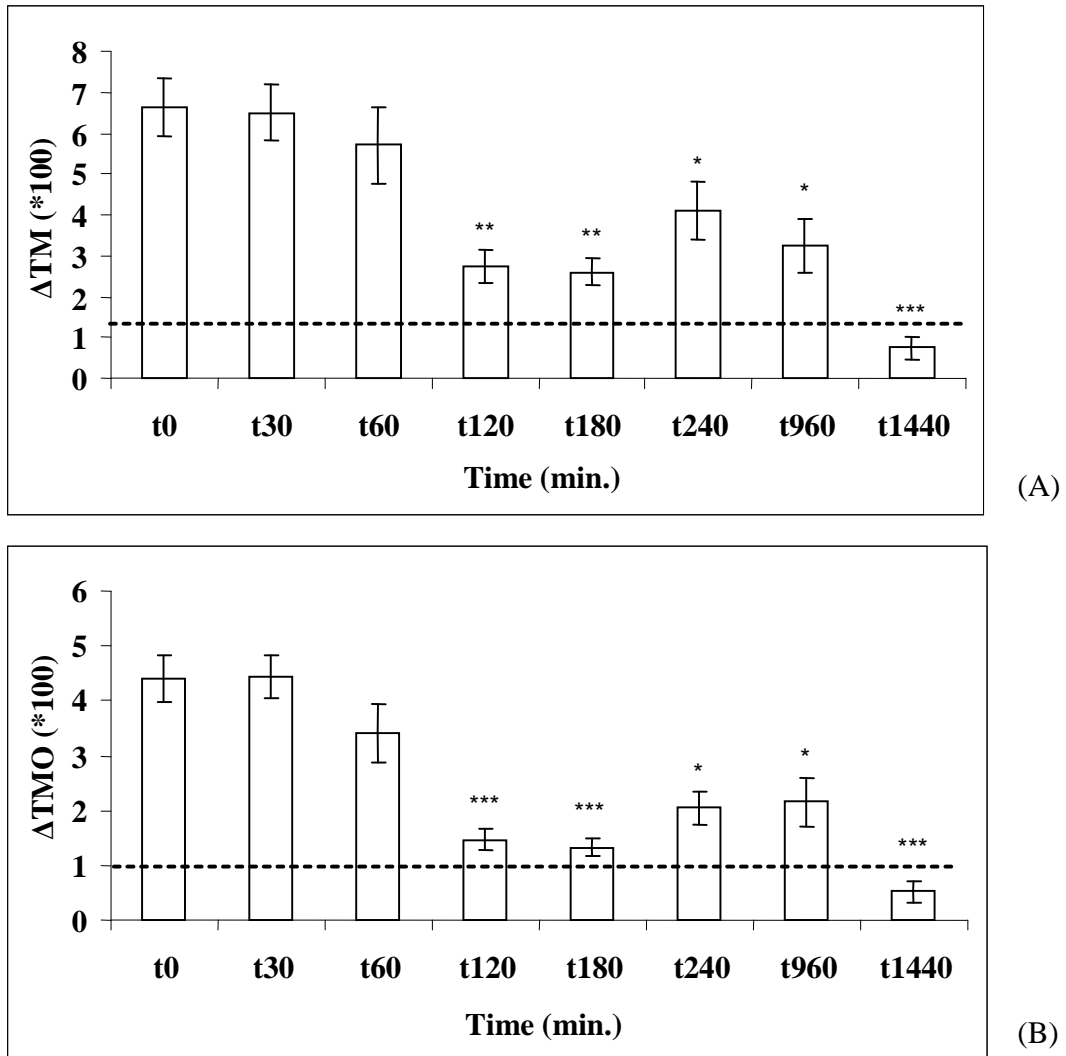

Figure 37. Δ TM (Tail Moment) (A) and Δ TMO (Tail Moment Olive) (B) for coelomocytes of *E. fetida*.

* p<0.05

** p<0.01

*** p<0.001

Kruskal-Wallis test followed by Dunn's multiple-comparison test (with respect to t0). Bars represent the standard error.

The dotted line shows the mean of controls (TM: 1.44; TMO: 0.99).

7.1.2. Repair enzymes – Endonuclease III and FPG

Concerning the genotoxic effects by adding Endonuclease III (EndoIII) and Formamidopyrimidine DNA glycosylase (FPG), preliminary experiments were performed to verify the absence of further breakages determined by the use of the enzyme reaction buffer or the presence of the two enzymes. Figure 38 (A) shows the results from the comparison between negative controls (50 μ L of PBS) and slides treated with enzyme reaction buffer (50 μ L). From the statistical analysis it can be argued that buffer did not significantly influence the breakage of DNA; moreover, no significant difference was observed, by comparing negative control slides (50 μ L of PBS) and samples exposed to EndoIII and

Results

FPG, respectively (1:1000, 50 μ L) (Fig. 38 (B), (C)). Similar results were obtained by considering the other genotoxicity parameters.

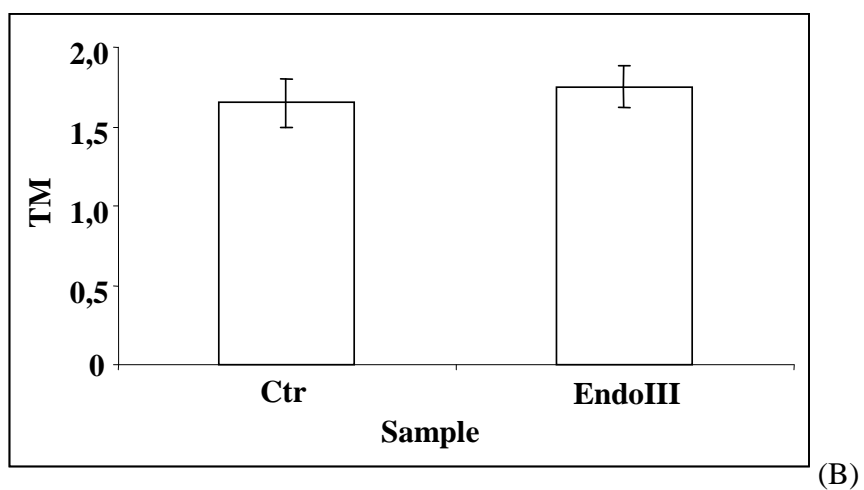
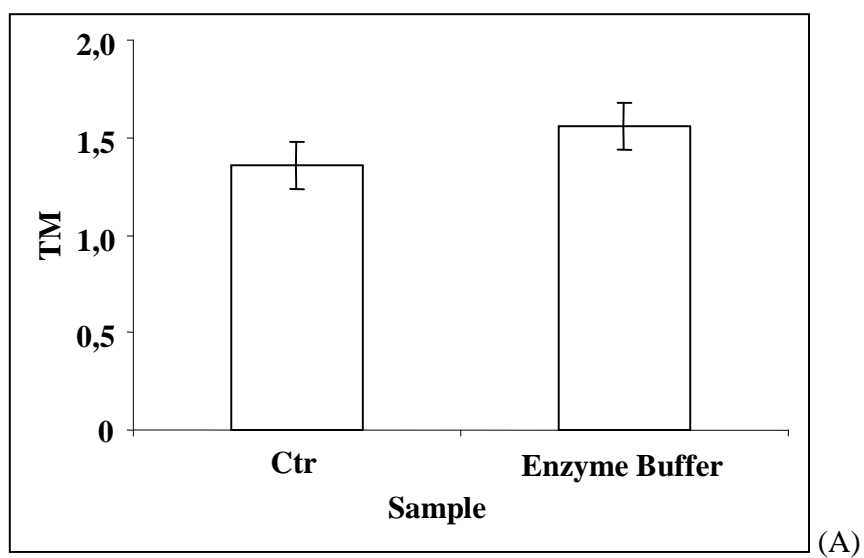

Results

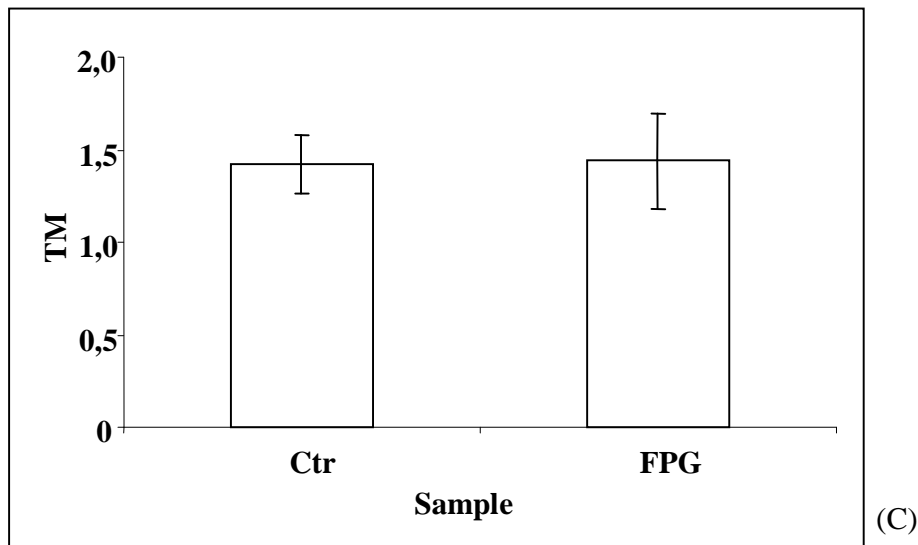
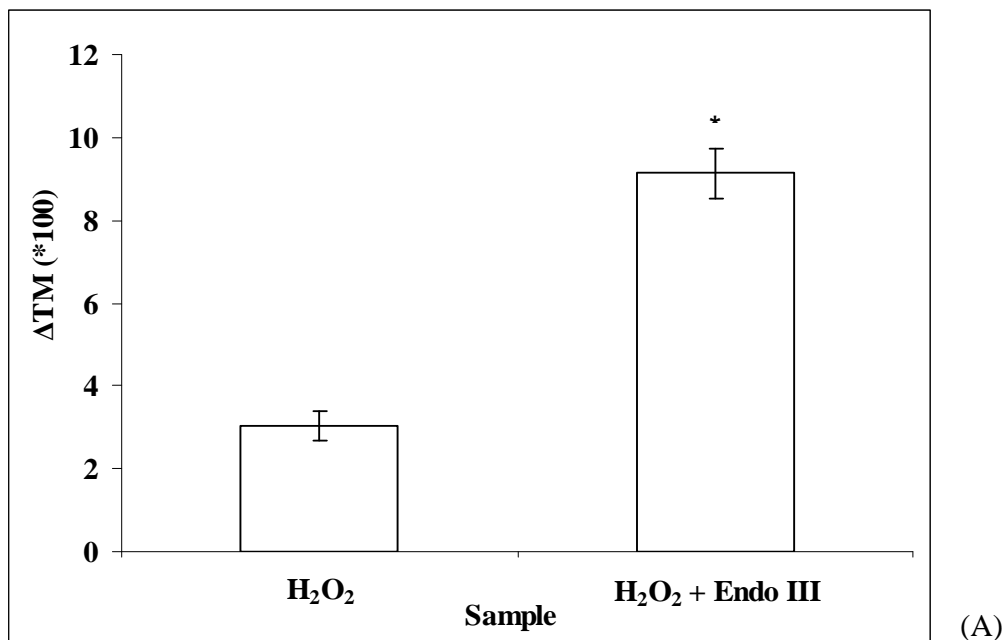

Figure 38. (A) Negative controls vs samples exposed to enzyme reaction buffer. (B) Negative controls vs samples exposed to EndoIII. (C) Negative controls vs samples exposed to FPG. Bars represent the standard error. No significant difference was observed at any comparison (Student's t test, $p > 0.05$). TM: Tail Moment; Ctr: Control.

In order to standardize the enzyme treatment for oxidative DNA detection, coelomocytes from individuals of *E.fetida* were exposed either to H_2O_2 ($30\mu M$ for 10 minutes) or simultaneously to the oxidant agent and one of the enzymes (EndoIII, 1:1000; FPG, 1:1000); in addition, negative controls by adding $50\mu L$ of PBS were used. DNA damage was significantly higher for cells exposed to H_2O_2 plus enzyme than cells exposed to hydrogen peroxide alone (Figure 39 (A), (B)).



Results

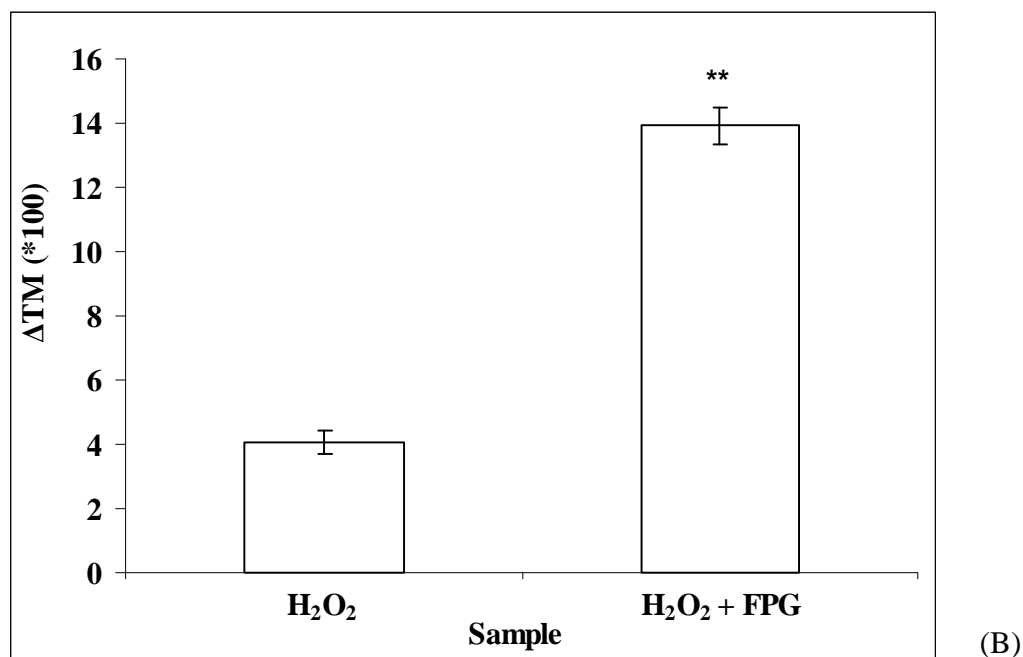

Figure 39. (A) Comparison between oxidative damage after peroxide oxygen alone and in combination with enzyme Endonuclease III and (B) in combination with Formamidopyrimidine DNA glycosylase, respectively.

* $p < 0.05$ (Mann-Whitney test)

** $p < 0.001$ (Mann-Whitney test)

Data expressed as differences between exposed and respective controls averages; bars represent the standard error.

When ceolomocytes were incubated at 37°C with EndoIII or FPG, after microwave treatment, oxidized pyrimidines were revealed by the comet assay (Figure 40); the initial production of these breakages were less evident in the first intervals of recovery, since they were superimposed on an high level of strand breaks. After two hours of recovery, when the strand breaks have decreased, endonuclease III-sensitive breaks could be estimated (Figure 40 (A)). In addition, after 24 hours from microwave exposure, the breaks originated by the presence of enzyme were more evident. Analogous results have been obtained using FPG enzyme, and the estimation of oxidative stress was observed in correspondence with 24 hours after microwave treatment (Figure 40 (B)). For both the conditions, the high level of DNA breaks in ceolomocytes between 2 and 24 hours represent long-lived intermediates in the repair of oxidized bases. In fact, the genotoxic parameters for Endonuclease III and FPG were 6.78 ± 0.92 and 15.79 ± 1.75 at 24 hours, respectively. In addition, the genotoxicity values for EMF exposure alone after 24 hours of recovery (0.42 ± 0.16 ; 0.71 ± 0.18) during the addition of EndoIII and FPG, respectively, were comparable to the respective controls (1.00 ± 0.07 ; 1.23 ± 0.07). This trend confirms the long interval of time occurring for the repair of oxidized bases. Finally, it has to be noted that the values of the genotoxic parameter (expressed as differences between exposed and respective controls) for EndoIII were higher only at t1440 ($p < 0.05$, Mann Whitney test) with respect to those data observed after FPG enzyme treatment, thus showing that oxidative damage might involves equally purine and pyrimidine bases. The repair mechanism of oxidized bases consists of removal of the bases by a glycosylase, breakage of phosphodiester backbone at the base-less site by an AP (apurinic or apyrimidinic site), deletion of the sugar-phosphate and polymerization of deoxyribonucleotides to fill

Results

the gap (Lindhal, 1993). Thus an interval of time, between the incision and the ligation step, is dedicated to the breakage of DNA.

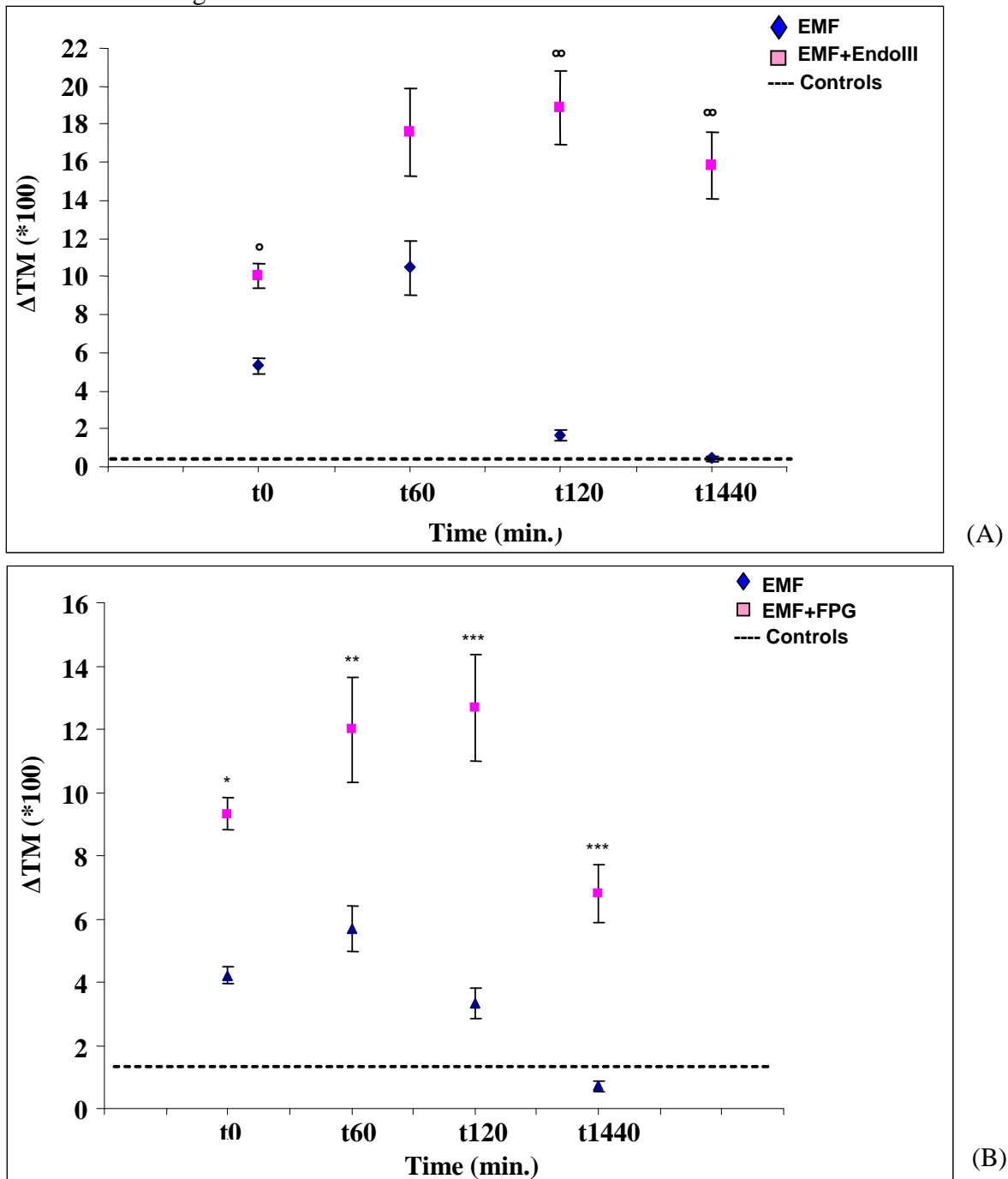

Figure 40. Repair of oxidative stress for DNA after Endonuclease III (A) and formamidopyrimidine-DNA glycosylase (B) treatment. After exposure to microwave field, cells were incubated at 37°C during SCGE analysis with (□) or without enzyme (◆). The dotted line represents the mean of controls. Bars indicate the standard error of the mean for the experiments of a given time.

° p<0.05, °° p<0.0001 Mann-Whitney test

* p<0.01, ** p=0.001, *** p<0.0001 Mann-Whitney test.

Results

7.1.3. UV rays exposure

Considering UVC exposure alone, we could observe a significant difference ($p < 0.001$) between t_0 and t_{60} , which represents the highest value for the genotoxic parameter, and no significant difference respect to the initial time was observed at the following times (Figure 41); in addition, Mann-Whitney test, by comparing the values of DNA damage for exposed and the respective controls for all the intervals of recovery confirmed that UV rays produced significant levels of damage after 1 hour ($p < 0.001$) from treatment, and that the values of ΔTM of irradiated animals did not result significantly different with compared to the controls at 2 hours after the exposure and for the following intervals of recovery.

Table 8 reports the results of the combinative effects induced by ultraviolet ray c and 900MHz microwaves exposure. Mann-Whitney test, by comparing ΔTM of UVC exposure alone (column 2 of table 8) and data obtained from Figure (41) did not evidence any significant difference, thus confirming the sensitivity and reproducibility of the comet test for this study. In fact, ΔTM values at 1 hour after the treatment to UVC alone (Table 8 column 2) were higher than those at t_0 (Mann-Whitney test), but values of genotoxicity were immediately comparable to those of initial time after 2 hours of recovery; this result was confirmed by comparing exposed to respective controls, where ΔTM values for exposed were higher with respect to those for controls at t_{60} (Mann-Whitney test $p < 0.001$).

A statistical significant difference was noted between t_0 and t_{960} for Tail Moment by considering the combinative exposure of the two physical agents (Table 8, column 3). Moreover, the results at 1 hour after the combined exposure of UVC plus radiofrequency demonstrated that the genotoxic parameters were significantly lower than those from UVC exposure alone ($p < 0.01$). Moreover, the results at the following times of recovery (t_{120} , t_{180} , t_{240} , t_{960} , t_{1440}) were significantly higher than those induced by UVC alone. Our data are analogous to previous results obtained for human cell lines (Baohong et al. 2007) demonstrating that microwave exposure can reduce and increase the DNA damage of human lymphocytes exposed to UVC radiation after 1.5 and 4h of incubation, respectively.

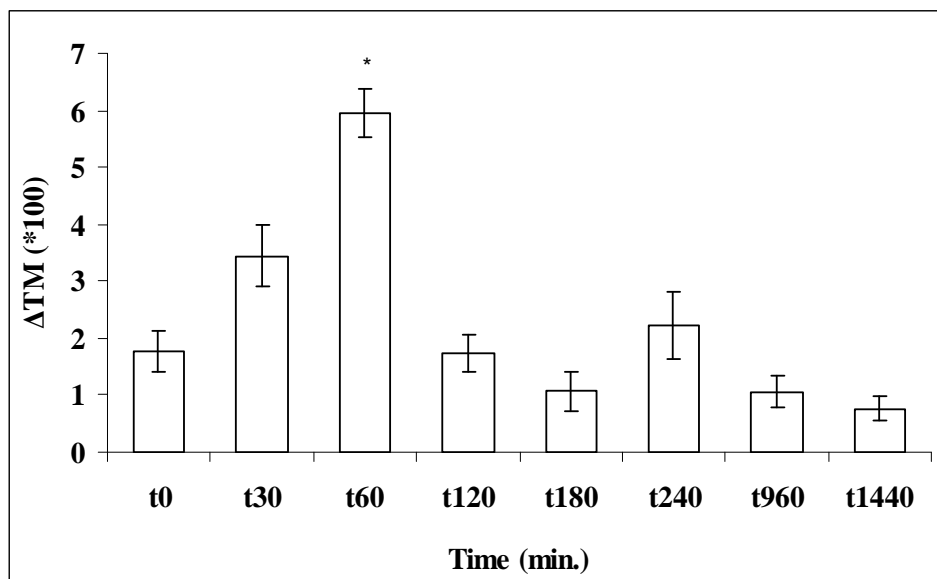

Figure 41. *E. fetida* coelomocytes DNA damage induced by UV rays exposure (UVC). Individuals were exposed for 15 minutes to 254nm UV rays.

* $p < 0.001$, Kruskal-Wallis test followed by Dunn's multiple-comparison test (with respect to t_0).

Results

T (min.)	Δ TM (UVC)	Δ TM (UVC+RF)
0	2.71±0.49	4.01±0.33
30	5.40±0.78	5.52±0.28
60	5.91±0.54 ^a	3.02±0.26 ²
120	2.58±0.43	4.00±0.38 ¹
180	1.91±0.48	6.04±0.44 ²
240	2.14±0.40	6.52±0.42 ²
960	0.75±0.23	12.01±0.74 ^{b,2}
1440	0.60±0.20	6.24±0.51 ²

Table 8. *E.fetida* coelomocytes DNA damage induced by UV rays exposure (UVC) alone and in combination with radiofrequency exposure (UVC+RF).

Δ TM: Tail Moment differences between exposed and respective controls averages.

^a As compared with t0, p<0.05. Kruskal-Wallis test followed by Dunn's test.

^b As compared with t0, p<0.01. Kruskal-Wallis test followed by Dunn's test.

¹ As compared with UVC groups, p<0.05. Mann-Whitney test.

² As compared with UVC groups, p<0.01. Mann-Whitney test.

7.1.4. Repair enzyme – T4 Endonuclease V

Enzyme buffer did not significantly affect the genotoxicity of coelomocytes, for the Tail Moment for negative controls (treated with PBS) and exposed to enzyme buffer were 1.10±0.11 and 1.50±0.18, respectively (p>0.05, Mann-Whitney test).

We chose two different times of recovery, t0 and t60, respectively, in order to study the effect of T4 endonuclease enzyme after three different levels of exposure, i.e. UVC 256nm exposure alone, microwave treatment alone and the combination of exposure to the two physical agents.

Figure 42 shows the results at initial time for all the combinations of exposure; no significant difference was observed between the genotoxic parameters for UVC exposure alone (Δ TM= 2.14±0.31) and the respective controls (Δ TM= 2.18±0.40) (p>0.05, Mann-Whitney test). The repair enzyme was able to increase the number of breaks after the exposure to UVC radiation at t0, for the damage was approximately four-fold the level of breaks from ultraviolet radiation alone (Δ TM of 3.42±0.36 and 13.88±1.61, respectively).

The use of Endonuclease V (T4PDG) after the exposure of organisms to microwave electromagnetic field did not affect the level of breakage after the stripline treatment, thus meaning that cyclobutane pyrimidine dimers, which are evidenced by using T4PDG, are not produced by microwaves.

A significant difference was not observed between the combining exposure of the two physical agents without or after the addition of the enzyme (p>0.05, Mann-Whitney test). Moreover, by considering that a significant difference was shown between UV+T4PDG and UV+RF+T4PDG, a possible interference of microwave 900MHz on the mechanisms of action of the repair enzyme might occur at t0.

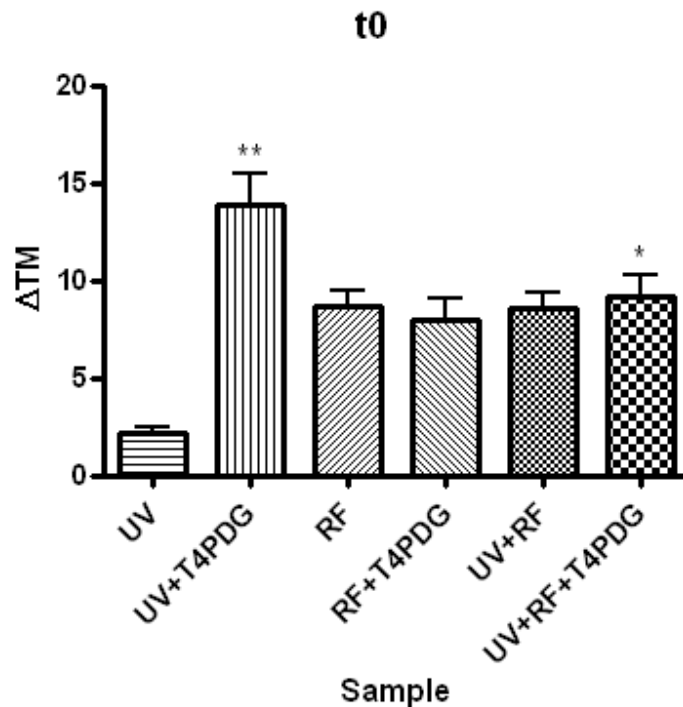

Figure 42. Influence of repair enzyme T4 Endonuclease V (T4PDG) on genotoxicity of single and combinative exposure of UVC rays (UV) and 900MHz electromagnetic fields (RF), respectively, at t0.

* as compared to UV+T4PDG, $p < 0.05$. Kruskal-Wallis test followed by Dunn's test.

** as compared to UV, $p < 0.001$. Mann-Whitney test.

Concerning t60 (Figure 43), the addition of T4 endonuclease V increased the value of TM after the exposure to UVC rays ($p < 0.05$); in particular, Tail Moment for UVC exposure alone and in combination with the repair enzyme was 10.15 ± 0.81 and 15.62 ± 1.11 , respectively. No significant difference ($p > 0.05$, Mann-Whitney test) was observed after the microwave treatment with or without the addition of T4PDG, thus confirming the absence of influence of this enzyme for RF exposure.

The results confirm that the presence of 900MHz electromagnetic field influences the mechanisms of repair after UVC dosage alone ($p < 0.001$, Mann-Whitney test). On the other hand, it can be also noted that the exposure to 256 nm UVC affected the damage induced by 900MHz microwave field, being the value of ΔTM for UV plus RF significantly lower ($p < 0.001$, Kruskal-Wallis test followed by Dunn's test) than the correspondent ΔTM for RF alone.

The combinative exposure of the two physical agents showed higher levels of Tail Moment with the use of the repair enzyme with respect to the mere exposure to UVC rays, followed by electromagnetic field exposure ($p < 0.001$). Taking into account that the combination of UV plus RF and T4 endonuclease V is significantly lower ($p < 0.05$) than 256 nm UV exposure with T4PDG, it can be hypothesized that 900MHz electromagnetic field is connected with the depletion of T4 endonuclease V activity.

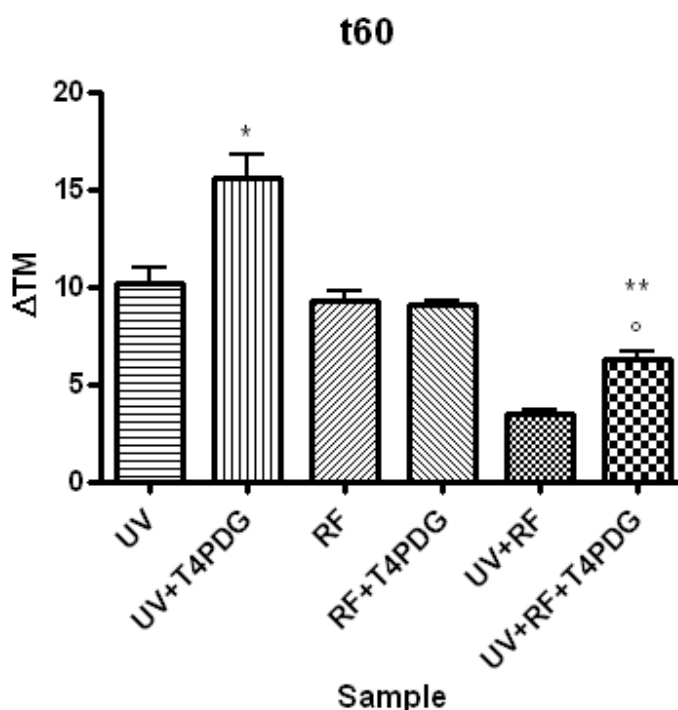

Figure 43. Influence of repair enzyme T4 Endonuclease V (T4PDG) on genotoxicity of single and combinative exposure of UVC rays (UVC) and 900MHz electromagnetic fields (RF), respectively, at t60.

* as compared to UV, $p < 0.05$. Mann-Whitney test.

** as compared to UV+RF, $p < 0.001$ Mann-Whitney test.

° as compared to UV+ T4PDG, $p < 0.05$ Kruskal-Wallis test followed by Dunn's test.

7.2. Results from field exposure

Four points of sampling with different levels of electric fields in the city of Milan were chosen for field experiments. Table 9 shows the results for electric field measured in the different areas of investigation; in particular, we assisted to an overcoming of threshold values imposed by the Italian legislation (20V/m) at point of sampling three, which was situated in the vicinity of a pediatric medical center.

Point Of Sampling	Electric Field (V/m) \pm S.D.	Min. Value	Max. Value
0	0.11 \pm 0.017	0.00	0.38
1	12.26 \pm 4.26	7.74	14.28
2	10.40 \pm 2.34	5.89	14.83
3	20.08 \pm 5.97	13.77	31.50

Table 9. Mean \pm S.D., minimum and maximum values of the electric field observed in all the points of sampling. Values were calculated in correspondence with the period of exposure to electromagnetic fields, considering the time course of the entire fieldwork.

0: Negative control point of sampling – Università Milano-Bicocca.

1: Piazza della Repubblica.

2: Via S.Galdino.

3: Via S.Galdino.

Results

Concerning the genotoxic results from field exposure, no significant difference between the Tail Moment from controls and exposed (3.65 ± 0.52 and 3.49 ± 0.46 , respectively) in the control site was found (Figure 44); however, a significant difference ($p<0.01$) in genotoxicity between sheltered animals and exposed in the three points of sampling in presence of a human electromagnetic source was found. Similar results were obtained for the other genotoxic parameters (data not shown). In particular, the highest value of Tail Moment (17.94 ± 1.28) was found in correspondence with the point of sampling in which the highest values of electric field were detected. Moreover, Tail Moment values from the animal exposed to electromagnetic fields at point 3 were significantly higher than those from the other points of sampling ($p<0.05$, Kruskal-Wallis Test, followed by Dunn's Multiple Comparison Test).

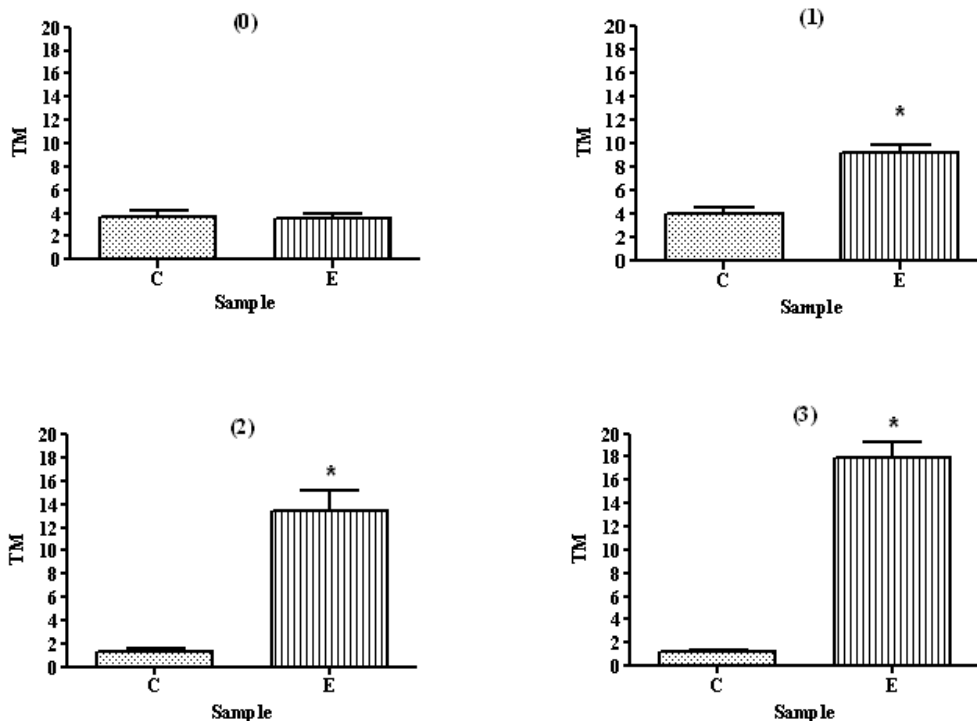

Figure 44. Mean and standard error of Tail Moment (TM) for controls (C) and exposed animals (E) calculated for the points of sampling.

0: Negative control point of sampling – University of Milano-Bicocca

1: Piazza della Repubblica

2: Via S.Galdino

3: Via S.Galdino

* $p<0.01$ -Mann-Whitney test.

In order to model the relationship between the anthropic electromagnetic fields and the genotoxic parameters, a simple regression analysis was performed. Preliminarily, a principal component analysis (PCA) was conducted in order to find interferences between genotoxicity and some air parameters. Figure 45 shows the results from PCA; component 1, which represented 54% of variability, showed the trend of the air parameters with O_3 concentrations and temperature in opposition to those contaminants typical of cold periods. Component 2, which represented 19% of total variability, showed a strict

Results

connection between the electromagnetic field values from anthropic sources and Tail Moment. Finally, the principal component analysis excluded any sort of influence of environmental parameters on genotoxic damage of coelomocytes and showed a strict connection between electric fields from human EMF sources and genotoxicity itself.

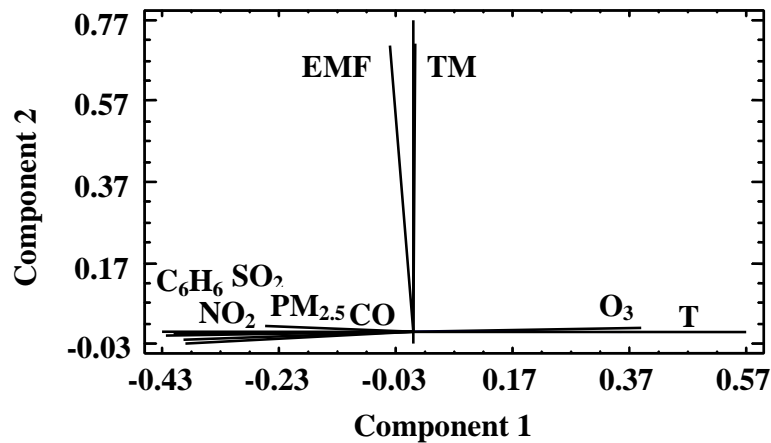

Figure 45. PCA relating some atmospheric parameters, the genotoxic parameters and the electric values from anthropic sources during the sampling period. TM: Tail Moment. EMF: Electromagnetic field.

Finally, the following simple linear regression analysis shows a significant relationship ($p < 0.001$) between the values of electric field detected during the field exposure for all the points of sampling and the corresponding value of Tail Moment from coelomocytes of the organisms exposed to EMF:

$$y = 1.47 + 0.59 x \quad (R^2 = 0.56).$$

8. DISCUSSION

There is a lot of concern about high and ultra-high frequency electromagnetic fields, however many controversial data on possible interactions between biological matter and microwaves have been proposed during these years (Hardell and Sage 2008); finally, there is not a univocal answer whether they can represent a hazard for human health and, generally, for the environment. Several investigations have also been directed to the assessment of genotoxic impact after radiofrequency electromagnetic fields (RF-EMF) exposure (Ruediger 2009, Verschaeve, 2005), but this remains a very complex issue; in particular, DNA damage *in vivo* is unsolved (Lai and Singh 1997, Lagroye et al. 2004) and many experiments are involved in obtaining data reproducibility and validation.

A very limited number of studies was performed on the genotoxic effects of microwaves exposure by using invertebrates (Dawe et al. 2009), and a few studies have explored the possible biological effects in ecology (Tkalec et al. 2009). For this reason we chose *E.fetida* as a possible tool to study whether DNA molecule is affected by microwaves exposure; in fact, this animal is a suitable tool in environmental investigations for its sensitivity to many stress, low cost and easy handling (OECD, 2000). Moreover, genotoxicity is easier to study for its hermaphroditism.

The damage on DNA was assessed by using comet assay. This molecular technique is a rapid, highly sensitive, and easy to perform method for the detection of single and double DNA strand breaks in individual cells. It can be conducted with every type of nucleated cell, and it is becoming more common in toxicology and ecotoxicology as a predictive biomarker to assess carcinogenic risk due to occupational or environmental exposure to genotoxic agents (Moller 2006, Di Marzio et al., 2005). Moreover, this molecular technique has been widely used to detect the DNA fragmentation induced by microwave exposure (Phillips et al. 2009). In our study, untreated cells always showed a low level of breaks (less than 10% of DNA in Tail) according to Collins (2004), thus confirming *E.fetida* as a suitable organism for assessing DNA damage with the comet assay.

In addition, preliminary tests with hydrogen peroxide confirmed *E.fetida* as a suitable tool for the assessment of genotoxicity by using comet assay; in fact, our data are in accordance with those obtained by Di Marzio et al (2005).

Coeelomocytes exhibited an elevated genotoxicity expressed as Tail Moment and Tail Moment Olive immediately after electromagnetic exposure; nevertheless, a transient damage has been observed, as animals were let to recover in absence of electromagnetic field until 24 hours after exposure. In fact, significant decreases of DNA fragmentation occurred after 2 hours of post-stress recovery, indicating the presence of some mechanisms that repair the breaks to the double and single strand of DNA. Some studies reported an increase in some biological endpoints (Yurekli et al., 2006; Otitolaju et al., 2010) by considering a far-field radiation, like that produced by base station antennas, while others (Sakuma et al., 2006; Hirose et al., 2007) demonstrated that the same kind of exposure did not alter some biological variables. It has also to be considered that two previous studies (Franzellitti et al., 2010; Nikolova et al., 2005) showed a low and reversible damage on DNA assayed by using comet test after exposure to microwave radiations, thus supporting the hypothesis that breaks on DNA can occur and that damages can be rapidly repaired.

One of the proposed mechanisms of interaction between living matter and energy of weak electromagnetic fields is the stimulation of oxidative stress processes by the formation of reactive oxygen species (ROS) (Campisi et al., 2010). In fact, they may lead to the formation of bulky lesion in DNA, one of the most dangerous being 8-OHdG, and the damage of other cellular compartments, like lipids (Sokolovic et al., 2008). Purified repair enzymes have been successfully used in combination with comet assay to detect specific kinds of oxidative damage, by converting particular lesions into

breaks (Collins et al., 1997b). In particular, the most sensitive repair enzymes are endonuclease III (EndoIII) and formamidopyrimidine DNA glycosylase (FPG) (Moller, 2006), which characterize oxidized pyrimidines and major purine oxidation product 8-oxoguanine as well as other altered purines, respectively (Collins, 2004).

Nevertheless, only a slight number of studies with the application of EndoIII and FPG to comet assay analysis have been performed to study the biological implications of EMF exposure (Gajski and Garaj-Vrhovac, 2009; Garaj-Vrhovac et al., 2009). Some authors studied the effects of oxidative repair enzymes during comet assay tests on fishes (Reeves et al., 2008) and invertebrates (Gielazyn et al., 2003; Emmanouil and Chipman, 2008), but no attempt to use earthworm to study oxidative stress with modified protocol of SCGE has been used, so far.

Preliminary results for standardization of the method by treating coelomocytes with hydrogen peroxide confirmed data found in literature (Zhu and Loft 2001; Minerva et al., 2006). In fact, DNA digested with both EndoIII and FPG, showed higher levels of damage on DNA molecule, so we can hypothesize that DNA breaks are introduced specifically at sites of oxidised pyrimidines and purine oxidation product 8-oxoguanine as well as other altered purines.

Up to now, only recent data, by analysing the potential use of bacterial repair enzymes for studying the consequences on the oxidative status of biological systems after exposure to microwave radiation have been proposed. Kim et al. (2008) observed anomalous low-field microwave absorption for *Escherichia coli* endonuclease III in the process of measuring the electron magnetic resonance, thus implying a potential connection between the DNA repair rate for the *Escherichia coli* endonuclease III and the anomalous microwave absorption. In addition, Gajski and Garaj-Vrhovac (2009) found an increase in genotoxicity with modified protocol of comet assay test after incubation with FPG of Wistar rat lymphocytes exposed to 915MHz electromagnetic field exposure.

Our data confirm the trend of genotoxicity after microwave exposure within the intervals of recovery, showing a significant diminish of Tail Moment 2 hours after the treatment with the stripline alone. In contrast with this situation, cells treated with both endonuclease III and formamidopyrimidine-DNA glycosylase showed higher values of genotoxic parameters with compared to the respective values for EMF exposure alone at any given time. Additional strand breaks after repair enzyme incubation represent repair intermediates deriving from both oxidised pyrimidines and oxidised purines; in addition, the high levels of Tail Moment observed along 24 hours of recovery time denote the extremely slow-time repair mechanism of break rejoining after low-power microwave exposure.

UV radiation, and in particular UVC, is a well-known physical mutagen (Sinha and Häder 2002). In particular, it does not produce damages on DNA directly, rather than the excision repair mechanisms produce DNA breaks as intermediates. Most of the breakages are quickly repaired by ligation step during the process of excision repair; nevertheless, DNA breaks are valuable when the number of excisions of DNA exceeds the number of DNA strand rejoining. In addition, the comet assay technique has been considered a reliable tool to detect the DNA fragmentation caused by this mutagenic agent (Gedik et al. 1992). Some biological responses in earthworms after UV exposures were investigated in previous studies; Sicken et al. (1999) found a dramatic increase in mortality in two earthworm species after exposure to solar radiation, especially UV-B component. Moreover, Chuang et al. (2006) noted abnormal physiological responses after ultraviolet radiations on *A. Gracilis*, and Hamman et al. (2003) found a decrease in the fertility of *E.fetida*. An increase in the generation of reactive oxygen species (ROS) that may form DNA base adducts in DNA and photooxidation of lipids were found in earthworms integument exposed to ultraviolet radiations (Misra et al. 2005). Owen et al. (2008) found genes associated with DNA damage, in particular, UV excision repair protein RAD23 homologue B and HUS1 like protein.

In addition, most of the studies concerning the genotoxic effects of UVC consist of *in vitro* experiments, where a great spectrum of biological systems, such as human lymphocytes (Moller et al., 2000), mammal cells (Rosa et al., 2007), invertebrates (Kaya et al., 2006) and plants (Armalytė and Zukas 2009) have been investigated. Nevertheless, only a slight amount of investigations, considering *in vivo* studies on DNA damage caused by UVC exposure have been collected (Qin et al., 1994; Iriti et al., 2007). For this reason, it is important to study the biological effects of UVC rays as a total body exposure.

Our results showed a significant increase in Tail Moment 1 hour after exposure, indicating that the maximal strand breaks results from the incision step of the excision repair mechanisms; nevertheless, the values of the genotoxic parameter promptly decreased after 2 hours from UVC exposure, thus suggesting that the enzymes involved in ligation step quickly repair the DNA fragmentation. Increasing values of comet tail length after exposure to UVC treatments were observed by Reinecke (2004) undergoing individuals of *E.fetida* to Ultralum UVC-508 Crosslinker. Similar results were obtained from previous studies on human lymphocytes (Zheng et al. 2005), where a transient DNA damage was detected by using the alkaline single-cell gel electrophoresis. Authors noted that the maximum level of damage occurred at 90 minutes from the exposure, confirming that the disequilibrium between breakages and DNA strand rejoining was evident about one hour after the treatment (Tuck et al., 2000). Our data also showed a transient level of breakage affected coelomocytes, for the genotoxic parameter promptly decreased thereafter to the level controls, thus suggesting that the ligation step is a quite rapid process. This is in accordance with available literature data on lymphocytes, where the value of Tail Moment was comparable to that of non-exposed at 4 hours after UV exposure (Yamauchi et al., 2002). Concerning the biological effects of a combinative exposure to UVC rays and radiofrequency radiations, some controversial studies have been reported about this issue. Leonard et al. (1983) indicated that microwaves could potentiate some genotoxic agents, like UVC rays. On the other hand, Meltz et al. (1987) did not find any alteration of DNA excision repair induced by either 350, 850, or 1200MHz radiofrequency exposure after UVC radiation in mammalian cells, as well as the evidence that RF exposures at the different frequencies examined interfered with three of the enzymatic steps of the DNA repair synthesis process, recognition of the damage to the DNA, nicking of the DNA, or repair.

Our results on the genotoxic effects caused by the combinative exposure of ultraviolet ray C plus 900MHz microwaves showed a diminish in the comet parameters 1 hour after the exposure, with respect to the UVC exposure alone. In addition, an increase in Tail Moment for UVC plus microwave exposure compared with UVC alone for the following intervals of recovery was observed. Ultraviolet radiation can induce bulky lesions in the DNA molecule, but it does not produce breaks directly; in fact, breakages are induced by the mechanism of repair in correspondence with the incision step, thus producing breaks as intermediates. As we could observed after the treatment with UVC alone, the disequilibrium between the incision and the ligation step was evident after 1 hour and the complete repair occurred within 2 hours after the exposure. However, in our experiments we observed that the genotoxic parameter of comet assay at 1 hour after UVC plus EMF exposure was lower than those caused by UVC alone at the corresponding time. In addition, ΔTM at 2 hours after the combinative treatment increased with respect to those induced by UVC at the corresponding interval of recovery.

For this reason, an interference of radiofrequency radiations with the mechanism of UV repair may be hypothesized, as they inhibit both the excision and the ligation step. On the other hand, another more recent study (Baohong et al. 2007) demonstrated that 1.8GHz microwave exposure could reduce and increase the DNA damage of human lymphocytes exposed to UVC radiation after 1.5 and 4h of incubation, respectively, thus evidencing an analogy with our results.

Discussion

Incubation with T4 endonuclease V increased UVC radiation-induced damage, confirming previous results obtained on rodent cells (Collins et al., 1997b) human keratinocytes (Rafferty et al., 2003) and plant cells (Sastre et al., 2001), where comet parameters increased immediately after irradiation. In addition, approximately 46% of the damage had still not been repaired, after 1 hour from UVC rays exposure. This is in accordance with the fact that cyclobutane pyrimidine dimers (CPDs) are the most common lesions caused by UVR.

Moreover, a decrease of genotoxic values considering the combining exposure to UVC and RF after incubation with the repair enzyme compared to the exposed to ultraviolet rays alone and T4 Endonuclease V was observed. A possible explanation of this condition might be due to fact that RF facilitates the ligation process after the excision step helped by the presence of T4PDG; however, according to our results, microwaves also influenced the ligation step of UVC-repair mechanisms, by increasing the genotoxic parameters. Therefore, we hypothesize that 900MHz electromagnetic field does not allow the enzyme to induce single-stranded breaks in ultraviolet-irradiated DNA; however, further investigations have to be perform to enlighten on this issue.

Only recently, some attempts to study the biological effects of phone masts on wildlife have been proposed. Balmori (2005) observed an interference with the reproduction of the white stork in vicinity of cellular phone base stations; moreover, a study on house sparrows (Everaert and Bauwens, 2007) revealed a negative relationship between the abundance of sparrows male and the levels of electric fields from 900 and 1800MHz mobile phone base stations. Balmori (2010) reported a low coordination of movements and an asynchronous growth of the common frog (*R.temporaria*) tadpoles exposed to four telephone base stations. Biological consequences on insects were also investigated; Weisbrot et al. (2003) found elevated Hsp70 levels in *Drosophila melanogaster* exposed to mobile phone radiation and, recently, a german study reported that most of the honeybees irradiated with DECT radiation did not return to the beehive and the honeycomb weight was lower in irradiated bees (Kimmel et al., 2007). Finally, studies of effects on plants were also reported in literature. Tkalec et al. (2009) found an increase of the mitotic index in root tips at 900MHz after exposure to higher field strengths or modulated fields in *Allium cepa* L meristematic cells, while a 2-hour exposure to lower field strengths at 900MHz as well as most of the treatments at 400MHz. In addition, some authors (Balodis et al., 1996) supposed that a base radio station could negatively affect the growth ratio of *Pinus sylvestris*, having found a negative correlation between the relative additional increment in tree growth and the intensity of the electric field.

There have been few attempts to study animals as possible bioindicators of low and high frequency radiations by performing field experiments; Regoli et al. (2005) used the land snail *Helix aspersa* as a valuable organism to assess a large panel of biological responses after extremely low frequency electromagnetic fields exposure (50Hz) under both laboratory conditions and on field. In particular, the authors found a raise in DNA damage by using alkaline comet assay test under increasing levels of magnetic field after laboratory treatments and a significant increase in genotoxicity parameters compared with to negative controls at different levels of EMF under field conditions.

Nevertheless, this report is the first attempt to consider a bioindicator species to assess the genotoxicity of radiofrequency exposure on field. Our results confirmed the high sensitivity of *E.fetida* to electromagnetic fields and the early responsiveness of the genotoxic parameters to microwaves exposure, thus indicating that this organism might be considered as a valuable tool for an ecotoxicological approach to evaluate the genotoxic effects caused by electromagnetic fields generated by anthropic sources. We chose three hot spots for electromagnetic fields in the city of Milan, by considering the data of Lombardy Regional Environmental Protection Agency (ARPA). The areas of sampling were characterized by different levels of electric field, arising from point 0 (very low field) to the maximum level detected at point of sampling no. 3. Our results showed a correspondance between

the levels of electric field detected with the FM100 probe during the interval of exposure and the genotoxic parameters calculated after the comet assay. Our data showed the highest damage on DNA (TM: 17.94 ± 1.28) in correspondence with the point of sampling 3, where the highest values of electric field (20.08 ± 1.28 V/m) was registered.

As monitoring programs are based on considering the environment as a whole and that organisms undergo a mixture of potentially toxic materials, we considered the influence of some environmental parameters for the assessment of DNA fragmentation of coelomocytes after the exposure of individuals to microwaves. PCA analysis showed a strict relationship between the electric field detected during the exposure and Tail Moment values, excluding any correlation with air parameters, according to the fact that the time of exposure was limited. Our statistical model confirmed this close relationship between EMF and genotoxicity, where a linear relationship was found between the two variables. By using our linear model, the corresponding value of Tail Moment to the threshold electric limit allowed by the Italian legislation (20V/m) is 13.27, that is about 3-fold the values of controls found during the biomonitoring. For the sensitivity and early response of *E. fetida* to EMF exposure, it could be interesting to deeply investigate the genotoxic effects of radiofrequency fields on the biota and developing valuable bioindicators in order to shine a light on this issue of public interest.

CONCLUSIONS

Our overall results on both laboratory and fields studies revealed a significant increase in DNA fragmentation by using the comet assay technique by radiofrequency electromagnetic fields on coelomocytes of *E. fetida*. This species has been indicated as a suitable biological indicator for its early responsiveness to microwave exposure alone and in combination with ultraviolet irradiation from laboratory experiments. Our results revealed a relevant but transient effect on DNA from 900MHz radiofrequency radiation, and a possible mutual interference between the two physical agents. Moreover, the repair enzymes used during our investigations revealed a possible stimulation of oxidative stress after RF exposure, indicating that this condition is maintained long after the treatment to microwaves. In addition, T4 endonuclease V enhanced the efficiency of the ligation step of excision repair mechanisms after UVC rays exposure alone, and microwaves seem to inhibit the action of the repair enzyme.

Finally, a positive and linear relationship between the electric field and the parameters of comet assay was detected during field experiments and no effects from other environmental parameters was found. Nevertheless, our report suggests going in depth with investigations in order to focus on the molecular mechanisms of radiofrequency electromagnetic fields genotoxicity.



9. REFERENCES

- Adamowicz A, Wojtaszek J (2001) Morphology and phagocytotic activity of coelomocytes in *Dendrobaena veneta* (Lumbricidae). *Zool Pol* 1–4:91–104.
- Adamowicz A (2005) Morphology and ultrastructure of the earthworm *Dendrobaena veneta* (Lumbricidae) coelomocytes. *Tissue Cell* 37:125–133.
- Adams SM (1990) Status and use of biological indicators for evaluating the effects of stress on fish. *American Fisheries Societies Symposium* 8:1-8.
- Adey WR (1981) Tissue interactions with non-ionizing electromagnetic fields. *Physiol Rev* 61:435–514.
- Affar EB, Dufour M, Poirier GG, Nadeau D (1998) Isolation, purification and partial characterization of chloragocytes from the earthworm species *Lumbricus terrestris*. *Mol Cell Biochem* 185:123–133.
- Alam MT, Barthakur N, Lambert NC, Kasatiya SS (1978) Cytological effects of microwave radiation in Chinese hamster cells *in vitro*. *Can J Genet Cytol* 20:23–30.
- Alvarez-Rodríguez Y, Rivas L, Rius C, Valladares Y (1985) White light-electromagnetic field interaction causes a localized destruction of cultured HeLa cells. *Cancer Lett* 29 (3):331-338.
- Andreuccetti D, Bini M, Checcucci A, Ignesti A, Millanta L, Olmi R, Rubino N (2001) Protezione dai campi elettromagnetici non ionizzanti. *Centro Stampa 2P, Firenze*.
- Anglesio L (2000) Guida tecnica per la misura dei campi elettromagnetici compresi nell'intervallo di frequenza 100 kHz-3 GHz in riferimento all'esposizione della popolazione. ANPA - RTI CTN_AGF 1/2000 (<http://www.ifac.cnr.it/pcemni/normeit/gtmcem.pdf>).
- Armalytè J, Zukas K (2009) Investigation of UV-induced DNA damage and its repair by SCGE assay. Personal communication (<http://www.ebiblioteca.lt/resursai/LMA/Biologija/B-57-1.pdf>).
- ARPA Lombardia (2005) Bollettino Ufficiale Regione Lombardia. 5° Supplemento Straordinario. (www.provincia.milano.it/ambiente/elettromagnetismo/doc/dgr_16febbraio2005_n7.pdf).
- Avel M (1959) Classe des Annelides Oligochaetes. In: *Traité de Zoologie Grassé PP, (ed), Paris, 224-470*.
- Babu GS, Joshi PC, Viswanathan PN (1998) UV-B induced reduction in biomass and overall productivity of cyanobacteria. *Biochem Biophys Res Commun* 244:138–142.
- Bailly V, Verly WG, O'Connor T, Jacques Laval (1989) Mechanism of DNA strand nicking at apurinic/apyrimidinic sites by *Escherichia coli* [formamidopyrimidine-DNA glycosylase]. *Biochem J* 262:581-589.

References

- Balcer-Kubiczek EK, Harrison GH (1991) Neoplastic transformation of C3H/10T1/2 cells following exposure to 120-Hz modulated 2.45-GHz microwaves and phorbol ester tumor promoter. *Radiat Res* 126:65–72.
- Balmori A (2005) Possible effects of electromagnetic fields from phone masts on a population of white stork (*Ciconia ciconia*). *Electromagn Biol Med* 24:109–119.
- Balmori A (2010) Mobile phone mast effects on common frog (*Rana temporaria*) tadpoles: the city turned into a laboratory *Electromagn Biol Med* 29:31-35.
- Balodis V, Brumelis G, Kalvinskis K, Nikodemus O, Tjarve D, Znotina V (1996) Does the Skrunda Radio Location Station diminish the radial growth of pine trees? *Sci Total Environ* 180 (1):65 – 73.
- Baohong W, Jiliang H, Lifen J, Deqiang L, Wei Z, Jianlin L, Hongping D (2005) Studying the synergistic damage effects induced by 1.8 GHz radiofrequency field radiation (RFR) with four chemical mutagens on human lymphocyte DNA using comet assay *in vitro*. *Mutat Res* 578 (1-2):149–157.
- Baohong W, Lifen J, Lanjuan L, Jianlin L, Deqiang L, Wie Z, Jiliang H (2007) Evaluating the combinative effects on human lymphocyte DNA damage induced by ultraviolet ray C plus 1.8 GHz microwaves using comet assay *in vitro*. *Toxicology* 232:311–316.
- Barrett JC, Vainio H, Peakall D, Goldstein BD (1997) 12th meeting of the scientific group on methodologies for the safety evaluation of chemicals: susceptibility to environmental hazards. *Environ Health Persp* 105 (Suppl. 4):699-737.
- Bergknut M, Sehlin E, Lundstedt S, Andersson PL, Haglund H, Tysklind M (2007) Comparison of techniques for estimating PAH bioavailability: uptake in *Eisenia fetida*, passive samplers and leaching using various solvents and additives. *Environ Pollut* 145(1):154-160.
- Berman E, Carter HB, House D (1980) Tests for mutagenesis and reproduction in male rats exposed to 2450-MHz (CW) microwaves. *Bioelectromagnetics* 1:65–76.
- Blaisdell JO, Harrison L, Wallace SS (2001) Base excision repair processing of radiation-induced clustered DNA lesions. *Radiat Prot Dosimetry* 97:25–31.
- Boiteux S, Huisman O, Laval J (1984) 3-Methyladenine residues in DNA induce the SOS function *sfIA* in *Escherichia coli*. *EMBO J.* 3(11):2569–2573.
- Boiteux S, Gajewski E, Laval J, Dizdaroglu M (1992) Substrate specificity of the *Escherichia coli* Fpg protein (formamidopyrimidine-DNA glycosylase): excision of purine lesions in DNA produced by ionizing radiation or photosensitization. *Biochemistry* 31(1):106–110.
- Brusick DJ (1995) An assessment of the genotoxic activity of radiofrequency radiation. In: *Proceedings of the Wireless Technology & Research, State-of-the-Science Colloquium, Rome, November 13–15.*

References

- Brusick DJ, Albertini R, McRee D, Peterson D, Williams G, Hanawalt P (1998) Genotoxicity of radiofrequency radiation. *Environ Mol Mut* 32:1-16.
- Bucheli TD, Fent K (1995) Induction of cytochrome P450 as a biomarker for environmental contamination in aquatic ecosystems. *Environ Contam Toxicol* 25:201-268.
- Burch SW, Fitzpatrick LC, Goven AJ, Venables BJ, Giggelman MA (1999) *In vitro* earthworm *Lumbricus terrestris* coelomocyte assay for use in terrestrial toxicity identification evaluation. *Bull Environ Contam Toxicol* 62(5):547-554.
- Burnet FM (1968) Evolution of the immune process in vertebrates. *Nature* 218:426-430.
- Byus CV, Kartum K, Pieper S, Adey WR (1988) Increased ornithine decarboxylase activity in cultural cells exposed to low-energy modulated microwave fields and phorbol ester tumor promoters. *Cancer Res* 48:4222-4226.
- Cahill D, Connor B, Carney JP (2006) Mechanisms of eukaryotic DNA double strand break repair. *Front Biosci* 11:1958-1976.
- Campisi A, Gulino M, Acquaviva R, Bellia P, Raciti G, Grasso R, Musumeci F, Vanella A, Triglia A (2010) Reactive oxygen species levels and DNA fragmentation on astrocytes in primary culture after acute exposure to low intensity microwave electromagnetic field. *Neurosci Lett* 473 (1):52 - 55.
- CEI - Comitato Elettrotecnico Italiano (2001) Guide for the measurement and the valuation of electromagnetic fields in the frequency range 10 KHz-300 GHz with reference to the human exposure. CEI, Milano.
- Chen WK (2005) *Electrical Engineering Handbook*. Elsevier Academic Press, Burlington USA.
- Chuang SC, Lai WS, Chen JH (2006) Influence of ultraviolet radiation on selected physiological responses of earthworms. *J Exp Biol* 209:4304-4312.
- Cleary SF, Liu LM, Merchant RE (1990) Glioma proliferation modulated *in vitro* by isothermal radiofrequency radiation exposure. *Radiat Res* 121:38-45.
- Cleary SF (1995) Effects of radio frequency radiation on mammalian cells and biomolecules *in vitro*. In: *Electromagnetic fields: biological interactions and mechanisms*, Blank M, (ed), Washington: American Chemical Society, 467-477.
- Collier TK, Johnson LL, Myers MS, Casillas E, Stein JE, Varansi U (1996) Incorporation of biomarkers into ecological risk assessments of contaminated nearshore marine habitats. *Mar Environ Res* 42:274-275.
- Collins AR, Dobson VL, Dusinská M, Kennedy G, Štetina R (1997a) The comet assay: what can it really tell us? *Mutat Res* 375:183-193.

References

- Collins AR, Mitchell DL, Zunino A, de Wit J, Busch D (1997b) UV-sensitive rodent mutant cell lines of complementation groups 6 and 8 differ phenotypically from their human counterparts. *Environ Mol Mutagen* 29(2):152-160.
- Collins AR (2004) The comet assay for DNA damage and repair: principles, applications, and limitations. *Mol Biotechnol* 26:249–261.
- Cooper EL (1996) Earthworm immunity. In: invertebrate immunology, Rincevich B and Müller WEG (eds), Springer, Berlin, 10–45.
- Cooper EL (2002) Comparative immunology. *Curr Pharm Design* 8:99-110.
- Cooper EL (2003) Comparative immunology . *Integr Comp Biol* 43(2):278-280.
- Csermely P (Ed.) (1998) Stress of life from molecules to man. *Annals of New York Academy of Sciences*, vol. 851. New York.
- Dalhus B, Arvai AS, Rosnes I, Olsen OE, Backe PH, Alseth Gao H, Cao W, Tainer JA, Bjoras M (2009) Structures of endonuclease V with DNA reveal initiation of deaminated adenine repair. *Nat Struct Mol Biol* 16:138–143.
- Daniells C, Duce I, Thomas D, Sewell P, Tattersall J, de Pomerai DI (1998) Transgenic nematodes as biomonitors of microwave-induced stress. *Mutat Res* 399 (1):55–64.
- David SS, Williams SD (1998) Chemistry of glycosylases and endonucleases involved in base-excision repair. *Chem Rev* 98:1221-1261.
- Dawe AS, Nylund R, Leszczynski D, Kuster N, Reader T, de Pomerai DI (2008) Continuous wave and simulated GSM exposure at 1.8 W/kg and 1.8 GHz do not induce hsp16-1 heat-shock gene expression in *Caenorhabditis elegans*. *Bioelectromagnetics* 29(2):92 – 99.
- Dawe AS, Bodhicharla RK, Graham NS, May ST, Reader T, Loader B, Gregory A, Swicord M, Bit-Babik G, de Pomerai DI (2009) Low-intensity microwave irradiation does not substantially alter gene expression in late larval and adult *Caenorhabditis elegans*. *Bioelectromagnetics* 30(8):602–612.
- DeCaprio AP (1997) Biomarkers: Coming of age for environmental health and risk assessment. *Environ Sci Tech* 31:1837-1848.
- Depledge MH (1994) The rational basis for the use of biomarkers as ecotoxicological tools. In: Nondestructive biomarkers in vertebrate, Fossi MC and Leonzio C, (eds), Lewis Publishers, Boca Raton, FL, 271-295.
- de Gruijl FR (1999) Skin cancer and solar UV radiation. *Eur J Cancer* 35:2003–2009.
- de Pomerai DI, Smith B, Dawe A, North K, Smith T, Archer DB, Duce IR, Jones D, Candido EP (2003) Microwave radiation can alter protein conformation without bulk heating. *FEBS Lett* 543(1-3): 93 – 97.

References

- Dhawan A, Bajpayee M, Parmar D (2008) Comet assay: a reliable tool for the assessment of DNA damage in different models. *Cell Biol Toxicol* 25(1):5-32.
- Dhawan A, Bajpayee M, Parmar D (2009) The comet assay: a versatile tool for assessing DNA damage. In: *The comet assay in toxicology*, Dhawan A and Anderson D, (eds), RSC, Cambridge, UK, 3-53.
- Di Carlo AL, Litovitz TA (1999) Is genetics the unrecognized confounding factor in bioelectromagnetics? Flock-dependence of field-induced anoxia protection in chick embryos *Bioelectrochem Bioenerg* 48:209–215.
- Diem E, Schwarz C, Adlkofer F, Jahn O, Ruediger HW (2005) Non-thermal DNA breakage by mobile-phone radiation (1800MHz) in human fibroblasts and in transformed GFSH-R17 rat granulosa cells *in vitro*. *Mutat Res* 583:178–183.
- Di Giulio RT, Washburn PC, Wenning RJ, Winston GW, Jewell CC (1989) Biochemical responses in aquatic animals: A review of determinants of oxidative stress. *Environ Toxicol Chem* 8:1103-23.
- Di Marzio WD, Saenz ME, Lemièrè S, Vasseur P (2005) Improved single-cell gel electrophoresis assay for detecting DNA damage in *Eisenia foetida*. *Environ Mol Mutagen* 46(4):246–252.
- Dizdaroglu M, Zastawny TH, Carmical JR, Lloyd RS (1996) Novel DNA N-glycosylase activity of *E. coli* T4 endonuclease V that excises 4,6-diamino-5-formamidopyrimidine from DNA, a UV-radiation- and hydroxyl radical-induced product of adenine *Mutat Res* 362(1):1–8.
- Dodson ML, Lloyd RS (1989) Structure-function studies of the T4 endonuclease V repair enzyme. *Mutat Res* 218:49-65.
- Durney CH, Massoudi H, Iskander MF (1986) *Radiofrequency radiation dosimetry handbook*, 4th Ed. SAM-TR-85-73, Brooks AFB, Texas.
- Ehling UH (1991) Genetic risk assessment. *Annu Rev Genet* 25:255–280.
- Emmanouil C, Chipman JK (2008) Excision of an oxidative DNA lesion (8-oxo-deoxyguanosine) in *Mytilus edulis* populations from two sites in the eastern Irish Sea. *J Environ Sci Heal A* 43(14):1586-1591.
- Evan G, Littlewood T (1998) A matter of life and cell death. *Science* 281:1317-1322.
- Everaert J, Bauwens D (2007) A possible effect of electromagnetic radiation from mobile phone base stations on the number of breeding house sparrows (*Passer domesticus*). *Electromagn Biol Med* 26:63-72.
- Eyambe GS, Goven AJ, Fitzpatrick LC, Venables BJ, Cooper EL (1991) A non-invasive technique for sequential collection of earthworm (*Lumbricus terrestris*) leukocytes during subchronic immunotoxicity studies. *Laborat Anim* 25:61-67.

References

- Fernandez-Capetillo O, Lee A, Nussenzweig M, Nussenzweig A (2004) H2AX: the histone guardian of the genome. *DNA Repair* 3:959–967.
- Foster KR Finch ED (1974) Microwave hearing: evidence for thermoacoustic auditory stimulation by pulsed microwaves. *Science* 185:256–258.
- Foster KR (2000) Thermal and nonthermal mechanisms of interaction of radio-frequency energy with biological systems. *IEEE TPS* 28 (1):15-23.
- Franzellitti S, Valbonesi P, Ciancaglini N, Biondi C, Contin A, Bersani F, Fabbri E (2010) Transient DNA damage induced by high-frequency electromagnetic fields (GSM 1.8GHz) in the human trophoblast HTR-8/SVneo cell line evaluated with the alkaline comet assay. *Mutat Res* 683 (1-2):35 – 42.
- Fränzele O (2006) Complex bioindication and environmental stress assessment. *Ecol Indic* 6:114–136.
- Friedberg EC (1985) *DNA Repair*. Freeman, New York.
- Friedberg EC, Walker GC, Siede W (1995) *DNA Repair and Mutagenesis*. ASM Press, Washington, DC.
- Fucic A, Garaj-Vrhovac V, Skara M, Dimitrovic B (1992) X-rays, microwaves and vinyl chloride monomer: their clastogenic and aneugenic activity, using the micronucleus assay on human lymphocytes. *Mutat Res* 282(4):265–271.
- Furness RW, Greenwood JJD, Jarvis PJ (1993) Can birds be used to monitor the environment? In: *Birds as monitor of environmental change*, Furness RW and Greenwood JJD (eds), Chapman & Hall, London, UK, 1-41.
- Gajski G, Garaj-Vrhovac V (2009) Radioprotective effects of honeybee venom (*Apis mellifera*) against 915-MHz microwave radiation-induced DNA damage in wistar rat lymphocytes: *in vitro* study. *Int J Toxicol* 28 (2):88 – 98.
- Gallagher PE, Duker NJ (1986) Detection of UV purine photoproducts in a defined sequence of human DNA. *Mol Cell Biol* 6:707–709.
- Gandhi GA (2005) Genetic damage in mobile phone users: some preliminary findings. *Indian Hum Genet* 11(2):99–104.
- Garaj-Vrhovac V, Fucic A, Horvat D (1990) Comparison of chromosome aberration and micronucleus induction in human lymphocytes after occupational exposure to vinyl chloride monomer and microwave radiation. *Periodicum Biologorum* 92:411–416.
- Garaj-Vrhovac V (1999) Micronucleus assay and lymphocyte mitotic activity in risk assessment of occupational exposure to microwave radiation. *Chemosphere* 39(13):2301-2312.

References

- Garaj-Vrhovac V, Gajski G, Trosic I, Pavicic I (2009) Evaluation of basal DNA damage and oxidative stress in Wistar rat leukocytes after exposure to microwave radiation. *Toxicology* 259 (3):107 – 112.
- Garson OM, McRobert TL, Campbell LJ, Hocking BA, Gordon I (1991) A chromosomal study of workers with long-term exposure to radiofrequency radiation. *Med J Aust* 155:289–292.
- Gary NE, Westerdahl BB (1981) Flight, orientation, and homing abilities of honeybees following exposure to 2.45-GHz CW microwaves. *Bioelectromagnetics* 2 (1):71–75.
- Gedik CM, Ewen SW, Collins AR (1992) Single-cell gel electrophoresis applied to the analysis of UV-C damage and its repair in human cells. *Int J Radiat Biol* 62(3):313–320.
- Gielazyn ML, Ringwood AH, Piegorsch WW, Stancyk SE (2003) Detection of oxidative DNA damage in isolated marine bivalve hemocytes using the comet assay and formamidopyrimidine glycosylase (Fpg). *Mutat Res* 542:15-22.
- Gil F, Pla A (2001) Biomarkers as biological indicators of xenobiotic exposure. *J Appl Toxicol* 21:245-255.
- Gonet B, Kosik-Bogacka DI, Kuzna-Grygiel W (2009) Effects of extremely low-frequency magnetic fields on the oviposition of *Drosophila melanogaster* over three generations. *Bioelectromagnetics* 30 (8):687–689.
- Goodman R, Blank M (2002) Insights into electromagnetic interaction mechanisms. *J Cell Physiol* 192:16-22.
- Goodman R, Lin-Ye A, Geddis MS, Wickramaratne PJ, Hodge SE, Pantazatos S, Blank M, Ambron RT (2009) Extremely low frequency electromagnetic fields activate the ERK cascade, increase hsp70 protein levels and promote regeneration in *Planaria*. *Int J Radiat Biol* 85(10):851-859.
- Gordon LK, Haseltine WA (1980) Comparison of the cleavage of pyrimidine dimers by the bacteriophage T4 and *Micrococcus luteus* UV-specific endonucleases. *J Biol Chem* 255(24):12047–12050.
- Griffiths AJF, Miller JH, Suzuki DT, Lewontin RC, Gelbart WM (1993) *An Introduction to Genetic Analysis*, 7th edition. Freeman, New York.
- Guler G, Tomruk A, Ozgur E, Seyhan N (2010) The effect of radiofrequency radiation on DNA and lipid damage in non-pregnant and pregnant rabbits and their newborns. *Gen Physiol Biophys* 29(1):59-66.
- Hamman A, Momo AR, Duhour A, Falco A, Sagario MC, Cuadrado E (2003) Effect of UV Radiation on *Eisenia fetida* populations. *Pedobiologia* 47:842-845.
- Hamnerius Y, Rasmuson A, Rasmuson B (1985) Biological effects of high-frequency electromagnetic fields on *Salmonella typhimurium* and *Drosophila melanogaster*. *Bioelectromagnetics* 6:405–414.
- Hanawalt P, Mellon I (1993) Stranded in an active gene. *Curr Biol* 3:67-69.

References

- Hardell L, Sage C (2008) Biological effects from electromagnetic field exposure and public exposure standards. *Biomed Pharmacother* 62(2):104-109.
- Hartmann A, Agurell E, Beevers C, Brendler Schwaab S, Burlinson B, Clay P, Collins A, Smith A, Speit G, Thybaud V, Tice RR (2003) Recommendations for conducting the *in vivo* alkaline comet assay. *Mutagenesis* 18:45–51.
- Hatahet Z, Kow YW, Purnal AA, Cunningham RP, Wallace S (1994) New substrates for old enzymes. *J Biol Chem* 269:18814–18820.
- Heflich RH, Neft RE (1994) Genetic toxicity of 2-acetylaminofluorene, 2-aminofluorene and some of their metabolites and model metabolites. *Mutat Res* 318(2):73-114.
- Hendawi M, Sauvé S, Ashour M, Brousseau P, Fournier M (2004) A new ultrasound protocol for extrusion of coelomocyte cells from the earthworm *Eisenia fetida*. *Ecotoxicol Environ Saf* 59:17–22.
- Hirose H, Sakuma N, Kaji N, Nakayama K, Inoue K, Sekijima M, Nojima T, Miyakoshi J (2007) Mobile phone base station emitted radiation does not induce phosphorylation of hsp27. *Bioelectromagnetics* 28:99–108.
- Holbrook NJ, Fornace AJ Jr (1991) Response to adversity: molecular control of gene activation following genotoxic stress. *New Biol* 3:825-833.
- Holdgate MW (1979) A perspective of Environmental pollution. Cambridge University Press, Cambridge, UK.
- Höytö A, Juutilainen J, Naarala J (2007) Ornithine carboxylase activity is affected in primary astrocytes but not in secondary cell lines exposed to 872 MHz RF radiation *Int J Radiat Biol* 83:367–374.
- ICNIRP – International Commission on Non-Ionizing Radiation Protection (1998) Guidelines for limiting exposure to time-varying electric, magnetic, and electromagnetic fields (up to 300 GHz). *Health Physics* 74 (4):494-522.
- Iriti M, Guarnieri S, Faoro F (2007) Responsiveness of *Lycopersicon pimpinellifolium* to acute UV-C exposure: histo-cytochemistry of the injury and DNA damage. *Acta Biochim Pol* 54:273–280.
- Italian DPCM (2003) Fissazione dei limiti di esposizione, dei valori di attenzione e degli obiettivi di qualità per la protezione della popolazione dalle esposizioni a campi elettrici, magnetici ed elettromagnetici generati a frequenze comprese tra 100 kHz e 300 GHz. G.U. 28/08/2003, No.199.
- Italian law (1998) Regolamento recante norme per la determinazione dei tetti di radiofrequenza compatibili con la salute umana. G.U. 03/11/1998, No.257.
- Iwai S, Maeda M, Shirai M, Shimada Y, Osafune T, Murata T, Ohtsuka E (1995) Reaction mechanism of T4 endonuclease V determined by analysis using modified oligonucleotide duplexes. *Biochemistry* 34:4601–4609.

References

- Iwama GK (1998) Stress in fish. In Csermely P (Ed), Stress of life from molecules to man. Annals of New York Academy of Sciences, 851:304–310.
- Jarosz J, Gliński Z (1997) Earthworm immune response. *Folia Bio.* 45:1–9.
- Jenrow KA, Smith CH, Liboff AR (1996) Weak extremely-low-frequency magnetic field-induced regeneration anomalies in the planarian *Dugesia tigrina*. *Bioelectromagnetics* 17(6):467 – 474.
- Jun SH, Kim TG, Ban C (2006) DNA mismatch repair system. Classical and fresh roles. *FEBS J* 273: 1609–1619.
- Karaka A (2010) Biology of earthworms. Springer, Germany.
- Kaya B, Kocaoglu S, Demir E (2006) Analysis of UV-stimulated recombination in the *Drosophila smart assay*. *Environ Mol Mutagen* 47:357–361.
- Kefuss J, M'Diaye K, Bounias M, Vanpoucke J, Ecochard J (1999) Biochemical effects of high intensity constant magnetic fields on worker honey bees *Bioelectromagnetics* 20(2):117–122.
- Kerbacher JJ, Meltz ML, Erwin DN (1990) Influence of radiofrequency radiation on chromosome aberrations in CHO cells and its interaction with DNA-damaging agents. *Radiat Res* 123:311–319.
- Khurana VG, Teo C, Kundi M, Hardell L, Carlberg M (2009) Cell phones and brain tumors: a review including the long-term epidemiologic data. *Surg Neurol* 72 (3):205–215.
- Kim SH, Kim HD, Youn B, Lee CH, Kim J (2008) Apparent low-field microwave absorption in *Escherichia coli* endonuclease III: a possible way for increased DNA damage by the microwave effect. *J Koeran Phys Soc* 52(4):1065-1069.
- Kim ST, Malhotra K, Smith CA, Taylor JS, Sancar A (1994) Characterization of (6-4) photoproduct DNA photolyase. *J Biol Chem* 269:8535–8540.
- Kimmel S, Kuhn J, Harst W, Hermann S (2007) Electromagnetic Radiation: Influences on Honeybees (*Apis mellifera*). Personal communication (<http://www.hese-project.org/hese-uk/en/papers>).
- Kitchen R (2001) RF & Microwave Radiation Safety Handbook. Newnes, London.
- Klaassen CD (2001) Casarett and Doull's Toxicology – The basic Science of Poison (6th edition). McGraw Hill, USA.
- Klein J (1997) Homology between immune responses in vertebrates and invertebrates: does it exist? *Scand J Immunol* 46: 558–564.
- Korte F. (ed.) (1987) Lehrbuch der Ökologischen Chemie. Grundlagen und Konzepte für die ökologische Beurteilung von Chemikalien. Thieme, Stuttgart.

References

- Kow YW, Wallace SS (1987) Mechanism of action of *Escherichia coli* endonuclease III. *Biochemistry* 26(25):8200-8206.
- Lagroye I, Anane R, Wettring BA, Moros EG, Straube WL, Laregina M, Niehoff M, Pickard WF, Baty J, Roti JLR (2004) Measurement of DNA damage after acute exposure to pulsed-wave 2450 MHz microwaves in rat brain cells by two alkaline comet assay methods. *Int J Radiat Biol* 80:11-20.
- Lai H (1998) Neurological effects of radiofrequency electromagnetic radiation. *Mobile Phones and Health, Symposium, October 25–28, University of Vienna, Austria, 1998*, see: <http://www.waveguide.org/library/lai.html>.
- Lai H, Singh NP (1995) Acute low-intensity microwave exposure increases DNA single-strand breaks in rat brain cells. *Bioelectromagnetics* 16:207–210.
- Lai H, Singh NP (1996) Single and double-strand DNA breaks in rat brain cells after acute exposure to radiofrequency electromagnetic radiation *Int J Radiat Biol* 69:513–521.
- Lai H, Singh NP (1997) Melatonin and a spin-trap compound block radiofrequency electromagnetic radiation-induced DNA strand breaks in rat brain cells. *Bioelectromagnetics* 18(6):446–454.
- Lai H, Singh NP (2004) Magnetic-field-induced DNA strand breaks in brain cells of the rat *Environ Health Perspect* 112:687–694.
- Laval J, Boiteux S, O'Connor TR (1990) Physiological properties and repair of apurinic/apyrimidinic sites and imidazole ring-opened guanines in DNA. *Mutat Res* 233:73–79.
- Lee KS, Choi JS, Hong SY, Son TH, Yu K (2008) Mobile phone electromagnetic radiation activates MAPK signaling and regulates viability in *Drosophila*. *Bioelectromagnetics* 29 (5):371–379.
- Leonard A, Berteaud AJ, Bruyère A (1983) An evaluation of the mutagenic, carcinogenic and teratogenic potential of microwaves. *Mutat Res* 123(1):31-46.
- Liao W, McNutt MA, Zhu WG (2009) The comet assay: a sensitive method for detecting DNA damage in individual cells. *Methods* 48:46–53.
- Lindhal T (1993) Instability and decay of the primary structure of DNA. *Nature* 362:702-715.
- Maes A, Collier M, Slaets D, Verschaeve L (1996) 954 MHz microwaves enhance the mutagenic properties of mitomycin C. *Environ Mol Mutagen* 28:26–30.
- Maes A, Van Gorp U, Verschaeve L (2006) Cytogenetic investigation of subjects professionally exposed to radiofrequency radiation. *Mutagenesis* 21(2):139–142.
- Malyapa RS, Ahern EW, Straube WL, Moros EG, Pickard WF, Roti Roti JL (1997) Measurement of DNA damage after exposure to electromagnetic radiation in the cellular phone communication frequency band (835.62 and 847.74 MHz) *Radiat Res* 148:618–627.

References

- Malyapa RS, Ahern EW, Bi C, Straube WL, LaRegina M, Pickard WF, Roti JLR (1998) DNA damage in rat brain cells after *in vivo* exposure to 2450 MHz electromagnetic radiation and various methods of euthanasia. *Radiat Res* 149(6):637-645.
- Manerikar RS, Apte AA, Ghole VS (2008) *In vitro* and *in vivo* genotoxicity assessment of Cr(VI) using comet assay in earthworm coelomocytes. *Environ Toxicol Phar* 25(1):63-68.
- Mashevich M, Folkman D, Kesar A, Barbul A, Korenstein R, Jerby E, Avivi L (2003) Exposure of human peripheral blood lymphocytes to electromagnetic field associated with cellular phones leads to chromosomal instability. *Bioelectromagnetics* 24:82-90.
- Mayer FL, Versteeg DJ, McKee MJ, Folmar LC, Franey RL, McCume DC Rattner BA (1992) Physiological and nonspecific biomarkers. In: *Biomarkers: biochemical, physiological, and histological markers of anthropogenic stress*, Huggett RJ, Kimerle RA, Mehrle PM Bergman HL (eds), Lewis, Boca Raton, FL, 5-86.
- Mazor R, Korenstein-Ilan A, Barbul A, Eshet Y, Sahadi A, Jerby E, Korenstein (2008) Increased levels of numerical chromosome aberrations after *in vitro* exposure of human peripheral blood lymphocytes to radiofrequency electromagnetic fields for 72 hours. *Radiat Res* 169:28-37.
- McArt DG, McKerr G, Howard CV, Saetzier K, Wasson GR (2009) Modelling the comet assay. *Biochemical Society Transactions* 37(4):914-917.
- McKeown SR, Robson T, Price ME, Ho ETS, Hirst DG, McKelvey-Martin VJ (2003) Potential use of the alkaline comet assay as a predictor of bladder tumour response to radiation *Br J Cancer* 89:2264-2270.
- Meltz ML, Walker KA, Erwin DN (1987) Radiofrequency (microwave) radiation exposure of mammalian cells during UV-induced DNA repair synthesis. *Radiat Res* 110:255-266.
- Meltz ML, Eagan P, Erwin DN (1989) Absence of mutagenic interaction between microwaves and mitomycin C in mammalian cells. *Environ Mol Mutagen* 13:294-303.
- Mezykowski T, Bal J, Debiec H, Kwarecki K (1980) Response of *Aspergillus nidulans* and *Physarium polycephalum* in microwave irradiation. *J Microw Power* 15:75-80.
- Minerva MA, Sandoval-Zapata F, Cabarez-Trejo A (2006) Oxidative DNA damage induced by thinner inhalation in rats lymphocytes. *Caryologia* 59(4):322-325.
- Misra RB, Lal K, Farooq M, Hans RK (2005) Effect of solar UV radiation on earthworm (*Metaphire posthuma*) *Ecotoxicol Environ Saf* 62:391-396.
- Mitchell DL, Karentz D (1993) The induction and repair of DNA photodamage in the environment. In: *Environmental UV photobiology*, Young AR, Björn L, Moan J, Nultsch W, Plenum, (eds), New York, 345-377.

References

- Moller P, Wallin H, Dybdahl M, Frentz G, Nexø BA (2000) Psoriasis patients with basal cell carcinoma have more repair-mediated DNA strand-breaks after UVC damage in lymphocytes than psoriasis patients without basal cell carcinoma. *Cancer Lett* 151:187–192.
- Moller P (2006) The alkaline comet assay: towards validation in biomonitoring of DNA damaging exposures. *Basic Clin Pharmacol Toxicol* 98:336–345.
- Nikolova T, Czyz J, Rolletschek A, Blyszczuk P, Fuchs J, Jovtchev G, Schuderer J, Kuster N, Wobus AM (2005) Electromagnetic fields affect transcript levels of apoptosis-related genes in embryonic stem cell-derived neural progenitor cells. *Faseb J* 31:425–433.
- OECD (2000) Guidelines for the Testing of Chemicals No. 207. Earthworm Acute Toxicity Tests, OECD, USA.
- Oktem F, Ozguner F, Mollaoglu H, Koyu A, Zu E (2005) Oxidative damage in the kidney induced by 900-MHz emitted mobile phone: protection by melatonin *Arch Med Res* 36(4):350–355.
- Otitoloju AA, Obe IA, Adewale OA, Otubanjo OA, Osunkalu VO (2010) Preliminary study on the induction of sperm head abnormalities in mice, *mus musculus*, exposed to radiofrequency radiations from global system for mobile communication base stations. *B Environ Contam Tox* 84:51–54.
- Ottaviani JJ, Carresque do F, Keen CL, Lazarus SA, Schimitz HH, Cesar CG (2002) Influence of flavan-3-ols and procyanidins on UVC-mediated formation of 8-oxo-7,8-dihydro-2'-deoxyguanosine in isolated DNA. *Arch Biochem Biophys* 406:203–208.
- Owen J, Hedley BA, Svendsen C, Wren J, Jonker MJ, Hankard PK, Lister LJ, Stürzenbaum SR, Morgan AJ, Spurgeon DJ, Blaxter ML, Kille P (2008) Transcriptome profiling of developmental and xenobiotic responses in a keystone soil animal, the oligochaete annelid *Lumbricus rubellus*. *BMC Genomics* 9: 266.
- Pakhomov AG, Dubovick BV, Kolupayev VE, Pronkevich AN (1991) Absence of non-thermal microwave effects on the function of giant nerve fibers. *J Bioelectricity* 10 (1-2):185 – 203.
- Palmbos PL, Wu D, Daley JM, Wilson TE (2008) Recruitment of *Saccharomyces cerevisiae* Dnl4-Lif1 complex to a double-strand break requires interactions with Yku80 and the Xrs2 FHA domain. *Genetics* 180 (4):1809–19.
- Panagopoulos DJ, Karabarbounis A, Margaritis LH (2004) Effect of GSM 900 MHz mobile phone radiation on the reproductive capacity of *Drosophila melanogaster* *Electromagn Biol Med* 23(1):29–43.
- Panagopoulos DJ, Chavdoula ED, Nezis IP, Margaritis LH (2007) Cell death induced by GSM 900-MHz and DCS 1800-MHz mobile telephony radiation. *Mutat Res* 626(1-2):69–78.
- Panagopoulos DJ, Chavdoula ED, Margaritis LH (2010) Bioeffects of mobile telephony radiation in relation to its intensity or distance from the antenna. *Int J Radiat Biol* 86(5):345–357.

References

- Parry MJ (1975) Evidence of mitotic division of coelomocytes in the normal, wounded and grafted earthworm *Eisenia foetida*. *Experientia* 32:449–451.
- Paulraj R, Behari J (2006) Single strand DNA breaks in rat brain cells exposed to microwave radiation. *Mutat Res* 596(1–2):76–80.
- Pavicic I, Trosic I (2008) *In vitro* testing of cellular response to ultrahighfrequency electromagnetic field radiation. *Toxicol In Vitro* 22:1344–1348.
- Pfeifer GP, You YH, Besaratinia A (2005) Mutations induced by ultraviolet light. *Mutat Res* 571:19–31.
- Phillips JL, Ivaschuk O, Ishida-Jones T, Jones RA, Campbell-Beachler M, Haggren W (1998) DNA damage in Molt-4 T-lymphoblastoid cells exposed to cellular telephone radiofrequency fields *in vitro*. *Bioelectrochem Bioenerg* 45:103–110.
- Phillips JL, Singh NP, Lai H (2009) Electromagnetic fields and DNA damage. *Pathophysiology* 16:79–88.
- Prentø P (1994) Uptake and long-time storage of natural and synthetic dyes by earthworms chloragocytes. *In vivo* and *in vitro* investigations. *Comp Biochem Physiol* 109A:805–816.
- Qi P, Todorova N, Todorov AT, Fendler JH, Rodziewicz GS (1995) Action potentials pass severed earthworm MGA segments reconnected by laser and electric field pulses. *Brain Res Bull* 37 (2):189 – 192.
- Qiao M, Chen Y, Wang CX, Wang Z, Zhu YG (2007) DNA damage and repair process in earthworm after *in vivo* and *in vitro* exposure to soils irrigated by wastewaters. *Environ Pollut* 148(1):141–147.
- Qin X, Zhang S, Nakatsuru Y, Oda H, Yamazaki Y, Suzuki T, Nikaido O, Ishikawa T (1994) Detection of active UV-photoproduct repair in monkey skin *in vivo* by quantitative immunohistochemistry. *Cancer Lett* 83 (1-2):291-298.
- Qu SX, Bai CL, Stacey NH (1997) Determination of bulky DNA adducts in biomonitoring of carcinogenic chemical exposures: features and comparison of current techniques. *Biomarkers* 2:3-6.
- Radman M (1976) An endonuclease from *Escherichia coli* that introduces single polynucleotide chain scission in ultraviolet-irradiated DNA. *J Biol Chem* 251:1438–1445.
- Rafferty TS, Green MH, Lowe JE, Arlett C, Hunter JA, Beckett GJ, McKenzie RC (2003) Effects of selenium compounds on induction of DNA damage by broadband ultraviolet radiation in human keratinocytes. *Br J Dermatol* 148(5):1001-1009.
- Rajaguru P, Suba S, Palanivel M, Kalaiselvi K (2003) Genotoxicity of a polluted river system measured using the alkaline Comet assay on fish and earthworm tissues. *Environ Mol Mutagen* 41(2):85–91.
- Reardon JT, Sancar A (2005) Nucleotide excision repair. *Prog Nuclei Acid Res Mol Biol* 79:183–235.

References

- Reeves JF, Davies SJ, Dodd NJF, Jha AN (2008) Hydroxyl radicals are associated with titanium dioxide (TiO₂) nanoparticle-induced cytotoxicity and oxidative DNA damage in fish cells. *Mutat Res* 640:113–122.
- Regoli F, Gorbi S, Machella N, Tedesco S, Benedetti M, Bocchetti R, Notti A, Fattorini D, Piva F, Principato G (2005). Pro-oxidant effects of extremely low frequency electromagnetic fields in the land snail *Helix aspersa*. *Free Radic Biol Med* 39 (12):1620–1628.
- Reinecke SA, Reinecke AJ (2004) The Comet assay as biomarker of heavy metal genotoxicity in earthworms. *Arch Environ Contam Toxicol* 46(2):208–215.
- Repacholi MH (1998) Low-level exposure to radiofrequency electromagnetic fields: Health effects and research needs. *Bioelectromagnetics* 19:1–19.
- Roots B, Johnston P (1966) The lipids and pigments of the chloragosomes of the earthworm *Lumbricus terrestris* L. *Comp Biochem Physiol* 17:285–288.
- Rosa RM, Moura DJ, Romano Silva AC, Saffi J, Pêgas Henriques JA (2007) Antioxidant activity of diphenyl diselenide prevents the genotoxicity of several mutagens in Chinese hamster V79 cells. *Mut Res* 63:44–54.
- Rothkamm K, Lobrich M (2003) Evidence for a lack of DNA double-strand break repair in human cells exposed to very low x-ray doses. *Proc Natl Acad Sci USA* 100:5057–5062.
- Rudd RL (1964) *Pesticides and the living landscape*. Faber and Faber, London, UK.
- Ruediger HW (2009) Genotoxic effects of radiofrequency electromagnetic fields. *Pathophysiology* 82:279-283.
- Rydberg B (1975) The rate of strand separation in alkali of DNA of irradiated mammalian. *Cells Radiat Res* 61:274-85.
- Sakar A, Ali S, Behati J (1994) Effects of low power microwave on the mouse genome: a direct DNA analysis. *Mutat Res* 320:141-147.
- Sakuma N, Komatsubara Y, Takeda H, Hirose H, Sekijima M, Nojima T, Miyakoshi J (2006) DNA strand breaks are not induced in human cells exposed to 2.1425 GHz band CW and W-CDMA modulated radiofrequency fields allocated to mobile radio base stations. *Bioelectromagnetics* 27:51-57.
- Sakumi K, Sekiguchi M (1990) Structures and functions of DNA glycosylases. *Mutat Res* 236:161–162.
- Salagovic J, Gilles J, Verschaeve L, Kalina I (1996) The Comet assay for the detection of genotoxic damage in the earthworms: a promising tool for assessing the biological hazards of polluted sites. *Folia Biol (Praha)* 42(1–2):17–21.
- Samiullah Y (1990) *Biological monitoring: animals*. MARC Report 27, GEMS Monitoring and assessment research centre, Kings College, London.

References

- Sancar A, Tang M (1993) Nucleotide excision repair. *Photochem Photobiol* 57:905-921.
- Sancar A (1996) DNA excision repair. *Annu Rev Biochem* 65: 43–81.
- Saparbaev M, Sidorkina OM, Jurado J, Privezentzev CV, Greenberg MM Laval J (2002) Repair of oxidized purines and damaged pyrimidines by *Escherichia coli* Fpg protein: different roles of proline 2 and lysine 57 residues. *Environ Mol Mutagen* 39:10–17.
- Sastre MP, Vernet M, Steinert S (2001) Single-cell gel/comet assay applied to the analysis of UV radiation-induced DNA damage in *Rhodomonas* sp. (Cryptophyta). *Photochem Photobiol* 74(1):55-60.
- Schuch AP, Menck CFM (2010) The genotoxic effects of DNA lesions induced by artificial UV-radiation and sunlight. *J. Photochem. Photobiol B: Biol* 99:111-116.
- Schwarz C, Kratochvil E, Pilger A, Kuster N, Adlkofer F, Rudiger HW (2008) Radiofrequency electromagnetic fields (UMTS, 1950 MHz) induce genotoxic effects *in vitro* in human fibroblasts but not in lymphocytes. *Int Arch Occup Environ Health* 81(6):755 – 767.
- Schlenk D (1999) Necessity of defining biomarkers for use in ecological risk assessment. *Mar Pollut Bull* 39:48-53.
- Schwan HP (1975) Dielectric properties of biological materials and interaction of microwave fields at the cellular and molecular level. In: *Fundamental and applied aspects of nonionizing radiation*, Michaelson SM and Miller MW (eds.), New York .
- Seeberg E, Eide L, Bjørås M (1995) The base excision repair pathway. *Trends Biochem Sci* 20:391–397.
- Sekijima M, Takeda H, Yasunaga K, Sakuma N, Hirose H, Nojima T, Miyakoshi J (2010) 2-GHz Band CW and W-CDMA Modulated radiofrequency fields have no significant effect on cell proliferation and gene expression profile in human cells. *J Radiat Res* 51(3):277-284.
- Shevell DE, Friedman BM., Walker GC (1990) Resistance to alkylation damage in *Escherichia coli*: role of the Ada protein in induction of the adaptive response. *Mutat Res* 233:53-72.
- Sharma VP, Kumar NR (2010) Changes in honeybee behaviour and biology under the influence of cellphone radiations. *Current Science* 98 (10): 1376 – 1378.
- Shugart LR (1998) Structural damage to DNA in response to toxicant exposure. In: *Genetics and ecotoxicology*, Forbes VE, (eds), Taylor & Francis Publishers, Philadelphia, USA, 151-168.
- Shugart LR (2002) DNA damage as a biomarker of exposure. *Ecotoxicology* 9:329-340.
- Shugart LR, Bickham J, Jakim G, McMahon G, Ridley W, Stein J, Steinert S (1992) DNA alterations. In: *Biomarkers: biochemical, physiological, and histological markers of anthropogenic stress*, Huggett RJ, Kimerle RA, Mehrle PM, Bergman HL, (eds), Lewis, Boca Raton, FL, USA, 125-154.

References

- Sicken O, Tienmann M, Schmelz RM, Kestler P, Westheide W (1999) Lethal effects of UV-radiation on lumbricid earthworms (*Eisenia fetida* and *Lumbricus terrestris*). *Pedobiologia* 43:874-879.
- Sicolo (2004) Messa a punto di metodiche per il monitoraggio in campo di effetti genotossici su *Eisenia fetida* esposta a campi elettromagnetici, Personal communication.
- Silbergeld EK, Davis DL (1994) Role of biomarkers in identifying and understanding environmentally induced disease. *Clin Chem* 40:1363-1367.
- Silva J, Freitas TRO, Marinho JR, Speit G, Erdtmann B (2000) Alkaline single-cell gel electrophoresis (Comet) assay for environmental *in vivo* biomonitoring with native rodents. *Genet Mol Biol* 23: 241-245.
- Šíma P, Větvička V (1990) Evolution of immune reactions. CRC Press Florida, USA.
- Singh NP, McCoy MT, Tice RR, Schneider EL (1988) A simple technique for quantification of low levels of DNA damage in individual cells *Exp Cell Res* 175:184-191.
- Sinha RP, Häder DP (2002) UV-induced DNA damage and repair: a review. *Photochem Photobiol Sci* 1:225-236.
- Sokolovic D, Djindjic B, Nikolic J, Bjelakovic G, Pavlovic D, Kocic G, Krstic D, Cvetkovic T, Pavlovic V (2008) Melatonin reduces oxidative stress induced by chronic exposure of microwave radiation from mobile phones in rat brain. *J Radiat Res (Tokyo)* 49 (6):579 – 586.
- Song Y, Zhu LS, Wang J, Wang JH, Liu W, Xie H (2009) DNA damage and effects on antioxidative enzymes in earthworm (*Eisenia foetida*) induced by atrazine. *Soil Biol Biochem* 41:905-909.
- Sonoda E, Hochegger H, Saberi A, Taniguchi Y, Takeda S (2006) Differential usage of nonhomologous end-joining and homologous recombination (HR) in double strand break repair. *DNA Repair* 5:1021-1019.
- Speit G, Hartmann A (2005) The Comet assay: a sensitive genotoxicity test for the detection of DNA damage. *Methods Mol Biol* 291:85-95.
- Spellberg IF (1991) Monitoring ecological change. Cambridge University Press, Cambridge, UK.
- Spurgeon DJ, Hopkin SP (1995) Extrapolation of the laboratory based OECD earthworm toxicity test to metal-contaminated field sites. *Ecotoxicology* 4:190-205.
- Stang-Voss (1971) Zur Ultrastruktur der blutzellen wirbelloser tiere IV. Die Hämocyten von *Eisenia foetida* L. (Sav.) (Annelidae). *Z. Zolforsch.* 117:451-462.
- Stein E, Avtalion RR Cooper EL (1977) The coelomocytes of the earthworm *Lumbricus terrestris*: morphology and phagocytic properties. *J Morphol* 153:467-478.
- Sung JS, Demple B (2006) Roles of base excision repair subpathways in correcting oxidized abasic sites in DNA. *FEBS J* 273:1620-1629.

References

- Suzuki J, Egami N (1983) Mortality of the earthworms, *Eisenia foetida*, after gamma-irradiation at different stages of their life history J Radiat Res (Tokyo) 24(3):209-220.
- Taylor J, Lu H, Kotyk JJ (1990) Quantitative conversion of the (6-4) photoproduct of TpdC to its Dewar valence isomer upon exposure to simulated sunlight. Photochem Photobiol 51:161–167.
- Thoma F (1999) Light, dark in chromatin repair: repair of UV-induced DNA lesions by photolyase and nucleotide excision repair. Embo J 18:6585–6598.
- Tkalec M, Malaric K, Pavlica M, Pevalek-Kozlina B, Vidakovic-Cifrek Z (2009) Effects of radiofrequency electromagnetic fields on seed germination and root meristematic cells of *Allium cepa* L. Mutat. Res. 672(2):76-81.
- Tuck A, Smith S, Larcom L (2000) Chronic lymphocytic leukemia lymphocytes lack the capacity to repair UVC-induced lesions. Mutat Res 459:73-80.
- Valembois P (1973) Etude ultrastructurale des coelomocytes du lumbriciden *Eisenia foetida* (Sav.), Bull. Soc Zool France 96:59–72.
- Valembois P, Lassegues M, Roch P (1992) Formation of brown bodies in the coelomic cavity of the earthworm *Eisenia fetida andreii* and attendant changes in shape and adhesive capacity of constitutive cells. Dev Comp Immunol 16:95–101.
- Valko M, Izakovic M, Mazur M, Rhodes CJ, Telser J (2004) Role of oxygen radicals in DNA damage and cancer incidence. Mol Cell Biochem 266:37–56.
- Verschaeve L, Maes A (1998) Genetic, carcinogenic, and teratogenic effects of radiofrequency fields. Mutat Res 410:141–165.
- Verschaeve L (2005) Genetic effects of radiofrequency radiation (RFR). Toxicol Appl Pharmacol 207:336–341.
- Verschuren K (1983) Handbook of environmental data on organic chemicals. Van Nostrand Reinhold, New York/Melbourne.
- Vijayalaxmi, Frei MR, Dusch SJ, Guel V, Meltz ML Jauchem JR (1997) Frequency of micronuclei in the peripheral blood and bone marrow of cancer-prone mice chronically exposed to 2450 MHz radio-frequency radiation Radiat Res 147:495–500.
- Ville P, Roch P, Cooper EL, Narbonne J (1997) Immueomodulator effects of carbaryl and 2,4-D in the earthworms *Eisenia fetida andreii*. Arch Environ Contam Toxicol 32:291–297.
- Wachtel H, Brown D, Bassen H (1990) Critical durations of pulse microwave exposures that evoke body movements. Abstract Bioelectromagnetics Society 12th Annu. Meeting, SanAntonio, TX, June10–14.
- Walker CH, Hopkin SP, Sibly RM, Peakall DB (1996) Biomarkers. In: Principles of ecotoxicology, Walker CH, Hopkin SP, Sibly RM, Peakall DB (eds). Taylor and Francis: London, UK, 175–194.

References

- Ward JF (1994) The complexity of DNA damage: Relevance to biological consequences. *Int J Radiat Biol* 66:427–432.
- Weisbrot D, Lin H, Ye L, Blank M, Goodman R (2003) Effects of mobile phone radiation on reproduction and development in *Drosophila melanogaster*. *J Cell Biochem* 89(1):48 – 55.
- WHO - World Health Organization (2000) Fact Sheet on Electromagnetic Fields and Public Health: Mobile Phones and Their Base Stations. World Health Organization, Geneva, CH.
- Wilson TE, Grawunder U, Lieber MR (1997) Yeast DNA ligase IV mediates non-homologous DNA end joining. *Nature* 388:495–498.
- Wood AW, Lubinas V, Joyner KH, Hocking BA (1993) Calcium efflux from toad heart: a replication study. In *Electricity and Magnetism in Biology and Medicine*, Blank M (ed), San Francisco Press, San Francisco, USA, 482–484.
- Xu S, Zhou Z, Zhang L, Yu Z, Zhang W, Wang Y, Wang X, Li M, Chen Y, Chen C, He M, Zhang G, Zhong M (2010) Exposure to 1800 MHz radiofrequency radiation induces oxidative damage to mitochondrial DNA in primary cultured neurons. *Brain Res* 1311:189–196.
- Yamauchi T, Keating MJ, Plunkett W (2002) 7-Hydroxystaurosporine inhibits DNA repair and increases cytotoxicity in normal lymphocytes and chronic lymphocytic leukemia lymphocytes the difference with respect to our results was the slower action of the ligation step of repair for human lymphocytes. *Mol Cancer Ther* 1:287-294.
- Yao K, Wu W, Yu, Zeng Q, He J, Lu D, Wang K (2008) Effect of superposed electromagnetic noise on lens epithelial cells induced by microwave radiation. *Invest Ophthalmol Vis Sci* 49:2009–2015.
- Yasuda S, Sekiguchi M (1970) T4 Endonuclease involved in repair of DNA. *Proceedings of the national academy of sciences* 67(4):1839-1845.
- Yurekli AI, Ozkan M, Kalkan T, Saybasili H, Tuncel H, Atukeren P, Gumustas K, Seker S (2006) GSM base station electromagnetic radiation and oxidative stress in rats. *Electromagn Biol Med* 25:177-188.
- Zheng W, He JL, Jin LF, Lou JL, Wang BH (2005) Assessment human DNA repair (NER) capacity with DNA repair rate (DRR) by comet assay. *Biomed Environ Sci* 17:397–401.
- Zhu CY, Loft S (2001) Effects of Brussels sprouts extracts on hydrogen peroxide-induced DNA strand breaks in human lymphocytes. *Food Chem Toxicol* 39(12):1191-1197.
- Zirmnerman U, Pilwat G, Riemann F (1974) Dielectric breakdown of cell membranes. *Biophys J* 14:881-889.
- Zmyslony M, Politanski P, Pajkowska E, Szymczak W, Jajte J (2004) Acute exposure to 930 MHz CW electromagnetic radiation *in vitro* affects reactive oxygen species level in rat lymphocytes treated by iron ions. *Bioelectromagnetics* 25:324–328.