

Miniaturized Radiochemical Purity Testing for ^{99m}Tc -HMPAO, ^{99m}Tc -HMDP and ^{99m}Tc -Tetrofosmin

Ana de la Fuente¹, PhD; Roberta Zanca¹; Roberto Boni¹, MD; Angela G. Cataldi¹, MS; Martina Sollini², MD; Elena Lazzeri¹, MD; PhD, Giuliano Mariani¹, MD; Paola A. Erba¹, MD, PhD

(¹) Regional Center of Nuclear Medicine, University of Pisa, Pisa, Italy

(²) Nuclear Medicine Unit, Department of Oncology and Advanced Technology, “Arcispedale Santa Maria Nuova” – IRCCS, Reggio Emilia, Italy

Address for correspondence:

Paola A. Erba, MD, PhD
Regional Center of Nuclear Medicine
University of Pisa
Via Roma 55
I-56125 Pisa, Italy
Tel: +39-050-992115 ; Fax: +39-050-992124
E-mail: paola.erba@unipi.it

17 Pages, 2923 words, 3 figures, 1 table, 13 Refs

ABSTRACT

Quick methods are functional in clinical practice in order to ensure the fastest availability of radiopharmaceuticals. For this purpose, we investigated the radiochemical purity of the widely used ^{99m}Tc -HMDP (hydroxymethylene diphosphonate), ^{99m}Tc -HMPAO (hexamethylpropyleneamine oxime) and ^{99m}Tc -Tetrofosmin by reducing time as compared to the manufacturer's method.

Methods: We applied a miniaturized chromatographic method with a reduced strip development from 18 cm to 9 cm for all three radiopharmaceuticals. The specific support media and solvent system of manufacturer's methods was kept unchanged for ^{99m}Tc -HMDP and ^{99m}Tc -Tetrofosmin while for ^{99m}Tc -HMPAO the ITLC polysilicic gel (ITLC-SA) was replaced with a monosilicic gel (ITLC-SG) in the chromatographic system that uses methyl ethyl ketone (MEK) as solvent. The method was applied and compared to the routine ITLC insert method in a total of 30 batches for each radiopharmaceutical. The precision of repeated tests was determined by comparison with the results of 10 replications on the same batch. Small volume of concentrated $^{99m}\text{TcO}_4$, and ^{99m}Tc -albumin nanocolloid were used to produce potential radiochemical impurities. Correlation between the quick methods and the insert methods was analyzed using a non-parametric two tiled test and a 2×2 contingency table with the associated Fisher exact test was used to evaluate sensibility and specificity. A ROC analysis was

performed to evaluate the best cut off. **Results:** The % of radiochemical purity (RCP) of the quick methods agree with the standard chromatography procedures. We found that $^{99m}\text{TcO}_4$ and colloidal impurities are not the only common radiochemical impurities with ^{99m}Tc -tetrofosmin and strip development reduction of ITLC manufacturer's method will worsen system's resolution and may produce potential inaccuracy. **Conclusion:** The miniaturized methods we described represent a fast and reliable alternative for ^{99m}Tc -Exametazime and ^{99m}Tc -Oxidronate quality control with the upper cut off for acceptable RCP values of 84%, 95% respectively. For ^{99m}Tc -Tetrofosmin RCP testing a longer strip as described in the standard method is warrant.

Key Words: quality control; ITLC; ^{99m}Tc -HMPAO; ^{99m}Tc -HMDP; ^{99m}Tc -tetrofosmin

INTRODUCTION

Testing of radiochemical purity is crucial for quality control assurance of radiopharmaceuticals in the daily routine of any nuclear medicine department. The procedures recommended by the manufacturer's package insert or by monographs in the European Pharmacopeia (1-3) for ^{99m}Tc -HMDP, ^{99m}Tc -HMPAO, and ^{99m}Tc -Tetrofosmin RCP testing are time consuming both for setting and development time. This makes problematic the adequate, timely use of these radiopharmaceuticals for some specific applications (such as, e.g., radiolabelling of autologous leukocytes which is optimal with freshly prepared ^{99m}Tc -HMPAO). In addition, it also conflicts with their useful half-life.

Over 35 years ago, Zimmer and Pavel (4) validated quick miniaturized chromatographic systems for radiopharmaceuticals which were at that time widely used in nuclear medicine, including ^{99m}Tc -labeled sulfur colloid, macroaggregated albumin (^{99m}Tc -MAA), stannous chloride, phytate, dimercaptosuccinic acid (^{99m}Tc -DMSA), diethylene triamine pentaacetic acid (DTPA), pyrophosphate, diphosphonate, methylene diphosphonate, polyphosphate, glucoheptonate. However, many new radiopharmaceuticals have subsequently been introduced into the clinical practice, thus requiring validation of the corresponding miniaturized RCP tests (5-7).

In the case of ^{99m}Tc -HMDP, the use of a modified Zimmer and Pavel technique performs poorly, as the peak of ^{99m}Tc -HMDP occurs earlier than the expected relative front (R_f) and thus overlaps with the peak of hydrolyzed reduced technetium (HRTc) (5).

Evolution of RCP testing for ^{99m}Tc -HMPAO has had some interesting twists. A miniaturized chromatographic RCP test was recommended in the original package insert of the commercial ^{99m}Tc -HMPAO labeling kit (revised in February 2006); such method has been replaced in January 2013 with a non-miniaturized method (8), most probably because of the difficulty in obtaining the desired separation of radiolabeled species using the traditional silica gel strips. Even more recently (in June 2013), the manufacturers have replaced silica gel with silicic acid (8).

Otherwise, the rapid RCP testing methods described so far for quality control of ^{99m}Tc -Tetrofosmin have either low sensitivity for unacceptable RCP values (9), or have been validated only with high purity batches (10).

These considerations prompted us to modify the chromatographic procedure for RCP testing of ^{99m}Tc -HMDP, ^{99m}Tc -HMPAO, and ^{99m}Tc -Tetrofosmin recommended by the manufacturers, with the aim of making them less time consuming. We report here the results of a series of tests performed for validation of such modified techniques.

MATERIALS AND METHODS

Radiopharmaceuticals

Thirty commercial kits of ^{99m}Tc -HMDP, ^{99m}Tc -HMPAO and ^{99m}Tc -Tetrofosmin were reconstituted according to the package insert instructions. Since these radiopharmaceuticals generally do not present significant impurities, to demonstrate the ability of the system to detect RCP values below the accepted limit, we added ^{99m}Tc -HMDP and ^{99m}Tc -Tetrofosmin. Therefore, in a number of 10 preparations for each radiopharmaceutical we incorporated high concentrations and small volumes of ^{99m}Tc -sodium pertechnetate and/or ^{99m}Tc -albumin nanocolloids. The latter was chosen as a surrogate for HRTc (insoluble ^{99m}Tc dioxide and/or ^{99m}Tc -tin colloid) or for other hydrophilic impurities that stay at the origin in most TLC systems (11).

Miniaturized methods

The manufacturer's RCP testing methods were modified as follows: 1) we reduced size of the ITLC strips, which was set at 1×10.5 cm for all three radiopharmaceuticals (*versus* 2×20 cm in the standard method); 2) we reduced migration in the ITLC strip from 15 cm of the standard methods to 7.5 cm (Figure 1).

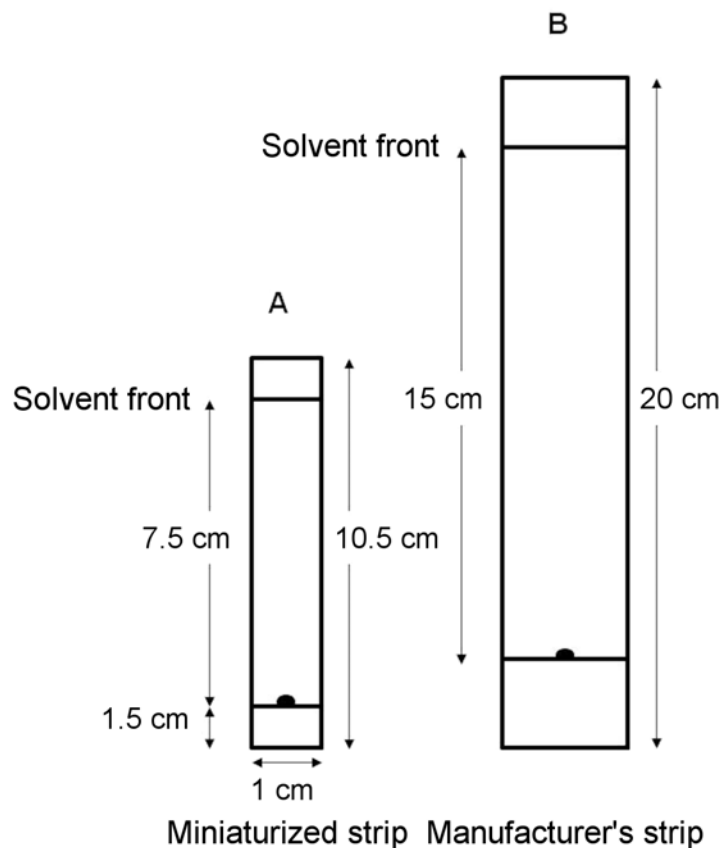

Figure 1 Chromatography diagrams of alternative (A) and standard (B) methods for RCP testing of radiopharmaceuticals.

Each strip was marked to ensure achievement of accurate migration levels: 1.5 cm as the origin line and 9 cm as the front line. Marking-pen lines were placed accordingly, to ensure that no overlapping occurred between the deposited radiopharmaceuticals and the marker. The solid phase was maintained as (Whatman) paper and polysilicic gel (ITLC-SA) for ^{99m}Tc -HMDP and ^{99m}Tc -Tetrofosmin, respectively, whereas in the case of ^{99m}Tc -HMPAO, inactivated

ITLC-SG was used instead of monosilic gel (ITLC-SA) as solid phase with MeOH. We kept unchanged all other components of the solvent system with respect to the corresponding manufacturer's methods (Table 1).

For all the procedures, we used adequately calibrated pipettes to control size of the spotted samples and to measure solvents; polypropylene blood withdrawal tubes were used as ascending chromatographic chambers.

RCP of each radiopharmaceutical batch obtained as described above was evaluated under their useful shelf-life using manufacturer's and miniaturized methods. To obtain 10 low purity batches of ^{99m}Tc -HMPAO, RCP test was carried out 30-60 minutes after reconstitution.

A phosphorimager (Cyclone Plus[®], Perkin Elmer) was used for the identification and quantification of radioactivity distribution along the chromatographic strips. Resolution greater than 1.5 was accepted to minimize integration errors possibly due to manual integration of the chromatographic peaks. The R_f ranges were kept unchanged for ^{99m}Tc -HMPAO and ^{99m}Tc -HMDP, while it was set at 0.3-0.9 for ^{99m}Tc -Tetrofosmin (versus 0.25-0.8 as recommended in the manufacturer's method) (Table 1).

Statistical Analysis

Correlations between the quick methods and the standard methods were evaluated using a non-parametric two-tailed test and a 2×2 contingency table,

while the associated Fisher exact test was used to assess sensitivity and specificity. An α -value of 0.05 was used to determine the validity of the new procedures. Precision of the modified methods was assessed by repeating 10 times the RCP test using samples from a single preparation for each radiopharmaceutical. Finally, ROC analysis was performed to identify the best cut-off for RCP testing.

RESULTS

^{99m}Tc-HMDP

The modified method shortened considerably the time required for RCP testing of ^{99m}Tc-HMDP to complete the quality control procedure, mainly by reducing the migration time from 50 minutes in the case of the standard method to 5 minutes only when the miniaturized strips are used.

In all 30 samples investigated with both methods using saline solution as the solvent, ^{99m}Tc-HMDP moved at the solvent front as a long smear rather than as a single discrete spot. This migration pattern prevented exact detection of HRTc impurities, because about 2% of the final ^{99m}Tc-HMDP compound was found in the expected R_f range of HRTc impurity. Whereas, 98% of the total ^{99m}Tc-HMDP activity was in the expected R_f range for the pure radiopharmaceutical (extending throughout 0.4-1). When ^{99m}Tc-pertechnetate was added and MeOH/H₂O was

used as the solvent, it produced a sharp peak separated at baseline with an R_f value of 0.8-1, in both the standard and the miniaturized methods (Table 1).

Table 1: R_f ranges for the peaks of most common ^{99m}Tc components in radiopharmaceutical preparations

Radiopharmaceutical	Component	Standard strips		Miniaturized strips	
		NaCl	MEK	NaCl	MEK
^{99m}Tc-HMPAO	^{99m}Tc - pertechnetate	0.8-1	0.8-1	0.8-1	0.8-1
	^{99m}Tc -colloid	0-0.4	0-0.2	0-0.2	0-0.2
	^{99m}Tc -HMPAO hydrophilic	0-0.4	0-0.2	0-0.2	0-0.2
	^{99m}Tc -HMPAO lipophilic	0-0.4	0.8-1	0-0.2	0.8-1
^{99m}Tc-HMDP	^{99m}Tc - pertechnetate	0- 0.15	0.4-1	0- 0.15	0.5-1
	^{99m}Tc -colloid	0- 0.15	0-0.4	0- 0.15	0-0.5
	^{99m}Tc -HMDP	0.4-1	0-0.4	0.4-1	0.5-1
^{99m}Tc-Tetrofosmin	^{99m}Tc - pertechnetate	AcO/DCM [†] 0.8-1		AcO/DCM 0.9-1	
	^{99m}Tc -colloid	0-0.25		0-0.3	
	^{99m}Tc -tetrofosmin	0.25-0.8		0.3-0.9	

*Solution of methanol to water 85:15 † Solution of acetone to dichloromethane 65:35

Figure 2 shows the correlation between the RCPs values obtained with the two methods ($R=0.94$, $P<0.0001$). With the miniaturized method, sensitivity for the detection of unacceptable RCP values ($<95\%$ purity) and specificity for acceptable RCP values ($>95\%$ purity) were both 100% ($P<0.0001$ by the Fisher

exact test), with accuracy ranging from 99% to 104%. Inter-assay variability was 0.4% for the manufacturer's method and 0.8% for the modified method.

^{99m}Tc-HMPAO

RCP testing of ^{99m}Tc-HMPAO using the manufacturer's instructions took approximately 30 minutes, because of the long chromatographic run and set-up procedures, while the miniaturized method with inactivated ITLC-SA /ITLC-SG strips was completed within approximately 10 minutes.

In the RCP testing of ^{99m}Tc-HMPAO, we found that with the standard method based on the use of ITLC-SA and saline as the solvent, the lipophilic ^{99m}Tc-HMPAO complex, the secondary ^{99m}Tc-HMPAO complex and HRTc migrated with a unique peak ranging from R_f 0 to 0.2. Any difference in pertechnetate resolution we found when we used the miniaturized method.

Otherwise in the MEK standard system which quantifies the secondary hydrophilic ^{99m}Tc-HMPAO complex and HRTc, ITLC-SG provided better resolution of those radiochemical species than ITLC-SA.

Figure 2 shows the highest correlation between RCPs values obtained with the miniaturized method and with the manufacturer's method, respectively (R=0.97; P< 0.0001).

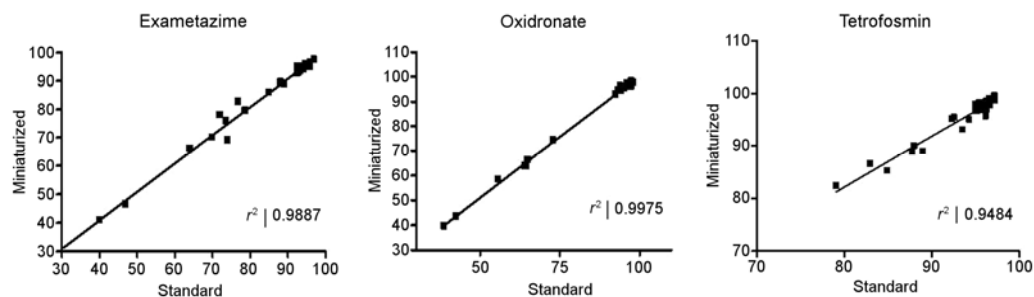

Figure 2 The Radiochemical purity of ^{99m}Tc -HMPAO (upper left), ^{99m}Tc -HMDP (upper right) and ^{99m}Tc -tetrofosmin (lower), obtained by standard and miniaturized strips in commercial reconstituted samples. The correlation coefficients were respectively 0.97, 0.93, 0.86 (with $P=0.0013$, $P<0.0001$, and $P<0.0001$, respectively).

Using the modified method, a 2×2 contingency table showed 92.8% sensitivity for the detection of unacceptable RCP values (<80% purity) and 100% specificity for acceptable RCP values (>80% purity). The associated Fisher exact test yielded ($p<0.0001$). With the very low purity batches the relative increase of the peak size for impurity with resolution below 1.0, generated unacceptable errors that prevented the calculation of accuracy. Inter-assay variability was under 1% for both methods. ROC analysis showed that the best cut-off for the quick miniaturized method is 84% of RCP (100% sensitivity and 100% specificity, $p<0.0001$).

^{99m}Tc -Tetrofosmin

The quick, miniaturized RCP method for ^{99m}Tc -Tetrofosmin requires only 5 minutes to be completed, thus comparing very favorably with the standard method (20 minutes).

We identified several critical technical issues of RCP testing for ^{99m}Tc -Tetrofosmin, including accuracy when preparing the sample volume, use of a freshly prepared solvent solution with strict control of the acetone to dichloromethane ratio, and meticulous attention to the solvent front, which should not migrate beyond the front line.

With the manufacturer's method, free ^{99m}Tc -pertechnetate runs to the top of the strip ($R_f = 0.8-1$), ^{99m}Tc -Tetrofosmin migrates to the center of the strip ($R_f = 0.5-0.6$) while colloidal impurities remain at the origin, along with two reduction impurities ($R_f = 0.1-0.2$) (Figure 3).

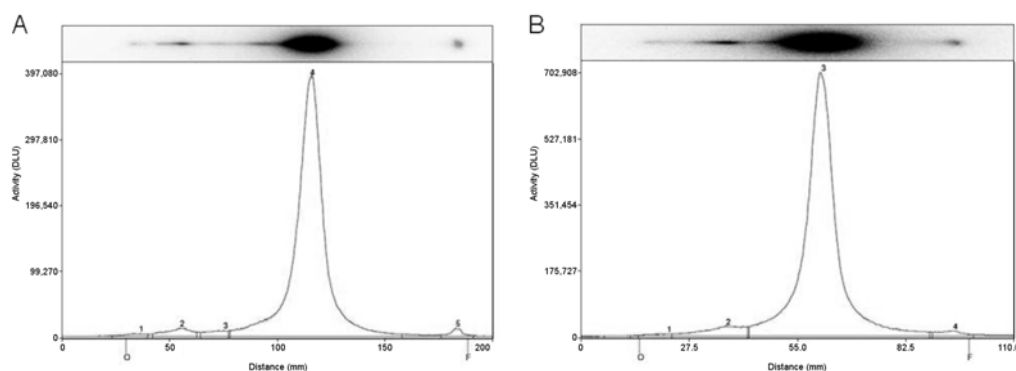

Figure 3 ITLC/SA with Acetone/Dichloromethane (85:65) of a batch of ^{99m}Tc -tetrofosmin: a) manufacturer's method: RCP 94.4%; b) miniaturized method: RCP 93.7%. The impurities are HRTc (peak 1), unknown impurities (peaks 2 and 3), ^{99m}Tc -tetrofosmin (peak 4), and $^{99m}\text{TcO}_4^-$ (peak 5) accounting for 2% of total radioactivity.

When following the labeling instructions, we never found free ^{99m}Tc -pertechnetate in any of the final preparations, except those where ^{99m}Tc -pertechnetate was added on purpose.

With the quick, modified method, the system's resolution worsened as the peak of ^{99m}Tc -tetrafosmin migrates more closely to the front line ($R_f = 0.6-0.7$), thus partly overlapping with the ^{99m}Tc -pertechnetate peak. Nevertheless, despite such poorer resolution, the presence of a 2% impurity of ^{99m}Tc -pertechnetate (or even more, as evaluated by the reference standard method) can readily be displayed with the quick method. Colloidal impurities did not migrate from the origin ($R_f = 0$), thus being well separated from the ^{99m}Tc -tetrafosmin peak. Whereas, the peaks of two additional unknown hydrophilic complex impurities at the bottom portion of the strips was found to overlap one to each other and with the ^{99m}Tc -tetrafosmin peak.

Figure 2 shows the correlation between the RCPs values obtained with the two methods ($R=0.85$, $p<0.0001$). Sensitivity of the quick miniaturized method for the detection of unacceptable RCP values ($<90\%$ purity) was 96%, while specificity for acceptable RCP values ($>90\%$ purity) was 100% ($p<0.0001$ by the Fisher exact test). Accuracy ranged from 98% to 102%. Inter-assay variability was 0.4% for the manufacturer's method and 0.7% for the modified method. ROC analysis yielded a 99% overall ability of the test to discriminate between

conformity and non-conformity ($P < 0.0001$), with 100% sensitivity and specificity with a 92% cut-off for RCP.

DISCUSSION

The miniaturized methods presented here include several modifications introduced with the purpose of speeding up the standard methods for RCP testing of three widely employed radiopharmaceuticals: ^{99m}Tc -HMDP, ^{99m}Tc -HMPAO, and ^{99m}Tc -Tetrofosmin. In particular, a critical feature of the miniaturized methods consists in reducing size of the ITLC strips, with consequent shortening of the migration time.

The main advantage of the quick method over the standard method for ^{99m}Tc -HMDP is the considerable shortening in the time required to complete testing. In fact, reduction of solvent migration from 15 cm (standard method) to 7.5 cm (miniaturized method) translates into shortening from 50 minutes to 5 minutes.

The miniaturized method for ^{99m}Tc -Tetrofosmin, shows an $R_f = 0.3-0.8$ as previously reported by McKay and colleagues (7) in a similar miniaturized system, which however has been validated only with high purity batches (>90%). Addition of free ^{99m}Tc -pertechnetate worsened resolution of the miniaturized system, due to partial overlap between the ^{99m}Tc -Tetrofosmin and the free ^{99m}Tc -pertechnetate peaks. However, it should be noted that free ^{99m}Tc -pertechnetate

was never found in any of the standard preparations. In addition, while the novel quick method clearly detected HRTc impurity in the bottom portion of the strip, it did not discriminate the two reduction impurity species described in literature either as a Tc(IV) or a Tc(III) product (12). Therefore, we can argue that miniaturized method might produce inaccurate results when RCP value lay near the cut-off line.

While no changes in the solid phase nor in the solvent systems were made for ^{99m}Tc -HMDP and ^{99m}Tc -Tetrofosmin, in the RCP testing for ^{99m}Tc -HMPAO (where MEK is used as the solvent) the solid phase was changed from monosilic ITLC-SA to ITLC-SG. In this regard, RCP testing for ^{99m}Tc -HMPAO is especially problematic due to the short time window between reconstitution and injection of this radiopharmaceutical into patients. Therefore, we resorted to the use of a miniaturized system which take approximately 5 minutes to develop, use blood collection tubes as developing chambers that require 5 minute to saturate with solvent and ITLC-SG instead of monosilic gel ITLC-SA which performs better with MEK as solvent.

CONCLUSION

The quick, miniaturized method here described for quality control of ^{99m}Tc -HMDP and ^{99m}Tc -HMPAO with reproducible RCPs values represents a valid

alternative to the standard methods. On the contrary, in the case of ^{99m}Tc -Tetrofosmin RCP testing, the use of a longer strip as described in the standard method is strongly recommended.

REFERENCES

- 1 Technetium (^{99m}Tc) exametazime injection In: European Pharmacopoeia 8.5, <http://online6.edqm.eu/ep805/> last access 01/2008:1925E.htm
- 2 Osteocis [package insert]. Milan, Italy: CIS bio S.p.A. October 2011
- 3 Myoview [package insert]. Milan, Italy: GE Healthcare; October 2010.
- 4 Zimmer AM, Pavel DG. Rapid miniaturized chromatographic quality control procedures for Tc-99m radiopharmaceuticals. *J Nucl Med.* 1977; 18:1230-1233
- 5 Williams CC. Re: radiochemical purity of Tc-99m oxidronate. *J Nucl Med.* 1981;11:1015-6
- 6 McKay BF, Zimmer AM, Spies SM. Rapid miniaturized chromatography for technetium-99m-tetrofosmin. *J Nucl Med Technol.* 1997;25:52-54
- 7 Geyer MC, Zimmer M, Spies WG, Spies SM, Hendel RC. Rapid quality control of technetium-99m-tetrofosmin: comparison of miniaturized and standard chromatography systems. *J Nucl Med Technol.* 1995;23:186-189.

- 8 Ceretec [package insert]. Milan, Italy: GE Healthcare; January 2013
- 9 Eggert LA, Dick MD, Mahoney DW, Olson JP, Werner GL, Hung JC. A rapid radiochemical purity testing method for ^{99m}Tc -Tetrofosmin. *J Nucl Med Technol* 2010; 38:81-84
- 10 Kanak CA, Sagar P, Aniruddha D, Gopal BS. An alternative method for determining the radiochemical purity of ^{99m}Tc -Tetrofosmin. *J Nucl Med Technol* 2011; 39:51–54.
- 11 Zolle I. Technetium-99m Pharmaceuticals Preparation and Quality Control in Nuclear Medicine. New York, NY, Springer, 2007: 345.
- 12 Hammes R, Joas LA, Kirschling TE, Ledford JL, Knox TL, Nybo ML, Sterzinger JJ. A better method of quality control for ^{99m}Tc -Tetrofosmin. *J Nucl Med Technol* 2004; 32:72-78.



Miniaturized Radiochemical Purity Testing for ^{99m}Tc -HMPAO, ^{99m}Tc -HMDP and ^{99m}Tc -Tetrofosmin

Ana de la Fuente, Roberta Zanca, Angela Gabriella Cataldi, Roberto Boni, Martina Sollini, Elena Lazzeri, Giuliano Mariani and Paola Anna Erba

J. Nucl. Med. Technol.

Published online: July 13, 2017.

Doi: 10.2967/jnmt.115.154484

This article and updated information are available at:

<http://tech.snmjournals.org/content/early/2017/07/12/jnmt.115.154484>

Information about reproducing figures, tables, or other portions of this article can be found online at:

<http://tech.snmjournals.org/site/misc/permission.xhtml>

Information about subscriptions to JNMT can be found at:

<http://tech.snmjournals.org/site/subscriptions/online.xhtml>

JNMT ahead of print articles have been peer reviewed and accepted for publication in *JNMT*. They have not been copyedited, nor have they appeared in a print or online issue of the journal. Once the accepted manuscripts appear in the *JNMT* ahead of print area, they will be prepared for print and online publication, which includes copyediting, typesetting, proofreading, and author review. This process may lead to differences between the accepted version of the manuscript and the final, published version.

Journal of Nuclear Medicine Technology is published quarterly.
SNMMI | Society of Nuclear Medicine and Molecular Imaging
1850 Samuel Morse Drive, Reston, VA 20190.
(Print ISSN: 0091-4916, Online ISSN: 1535-5675)

© Copyright 2017 SNMMI; all rights reserved.

 SOCIETY OF
NUCLEAR MEDICINE
AND MOLECULAR IMAGING